

# Energy Storage Options for North Carolina

## **PREPARED BY**

NC State Energy Storage Team

## **PREPARED FOR**

Energy Policy Council  
Joint Legislative Commission on Energy Policy



# The NC State Energy Storage Study Team

## Faculty and Staff

Joseph DeCarolis, Civil, Construction, and Environmental Engineering  
Ken Dulaney, FREEDM Center  
Harrison Fell, Agricultural and Resource Economics  
Christopher Galik, Public Administration  
Jeremiah Johnson, Civil, Construction, and Environmental Engineering  
Steve Kalland, NC Clean Tech Center  
Ning Lu, Electrical and Computer Engineering  
David Lubkeman, Electrical and Computer Engineering  
Isaac Panzarella, NC Clean Tech Center  
Autumn Proudlove, NC Clean Tech Center  
Anderson Rodrigo de Queiroz, School of Business, NC Central University  
Wenyuan Tang, Electrical and Computer Engineering

## Students

Asmaa Alrushoud, Electrical and Computer Engineering  
Chris Gambino, Public Administration  
Yao Meng, Electrical and Computer Engineering  
Ming Liang, Electrical and Computer Engineering  
Shuchi Liu, , Electrical and Computer Engineering  
David Mulcahy, Electrical and Computer Engineering  
Danny Sodano, Civil, Construction, and Environmental Engineering  
Dustin Soutendijk, Civil, Construction, and Environmental Engineering  
Lisha Sun, Electrical and Computer Engineering

# Table of Contents

Executive Summary ..... i

1. Introduction and Motivation ..... 1

2. Current Status of Energy Storage Deployment ..... 3

3. Storage Applications and Services ..... 10

4. Storage Technology Assessment ..... 15

5. Overview of Our Approach ..... 30

6.1. End-User Services ..... 33

6.2. Distribution Services ..... 51

6.3. Transmission Congestion Relief ..... 68

6.4. Transmission Investment Deferral ..... 77

6.5. Bulk Energy Time Shifting and Peak Capacity Deferral ..... 92

6.6. Frequency Regulation ..... 116

6.7. Solar Clipping ..... 130

7. Synthesis Across Service Categories and Value Stacking ..... 137

8. Possible Employment Impacts of Energy Storage Deployment in North Carolina ..... 145

9. Identification of Barriers and Policy Options ..... 147

10. Future Work ..... 170

Appendices ..... 172

## Executive Summary

### Introduction

Under House Bill 589, the NC Policy Collaboratory was tasked with producing a report on the value of energy storage to NC consumers. Over the last year, our team analyzed the potential role of storage within North Carolina, culminating in this report. Throughout this report, we have endeavored to be as transparent as possible in our analysis. A unique feature of our effort – unlike other state-level energy storage studies – is that we have also made the underlying models and data publicly available, where possible, in an effort to increase transparency and promote further discussion and debate among stakeholders. These materials are available through the project website.<sup>1</sup>

North Carolina’s power sector faces a rapidly increasing penetration of renewable energy as well as economic and environmental pressures to decrease coal-fired electricity production. We believe that now is the appropriate time to consider the role that energy storage may play in the state’s future power system. Energy storage can help ensure reliable service, decrease costs to rate payers, and reduce the environmental impacts of electricity production.

The electric power system is a very large and complex machine, and several grid-related services must be fulfilled simultaneously by different technologies. In addition, investor-owned utilities, municipal utilities and cooperatives, independent power producers, and consumers all play a role in how the grid functions. Energy storage can be utilized by different parties to fulfill many services and applications. We evaluate a set of storage technologies and applications, and perform benefit-cost analysis to determine where storage can add value. Given the commercially sensitive nature of some data, we are not able to evaluate all storage applications with equal analytical rigor.

### Approach

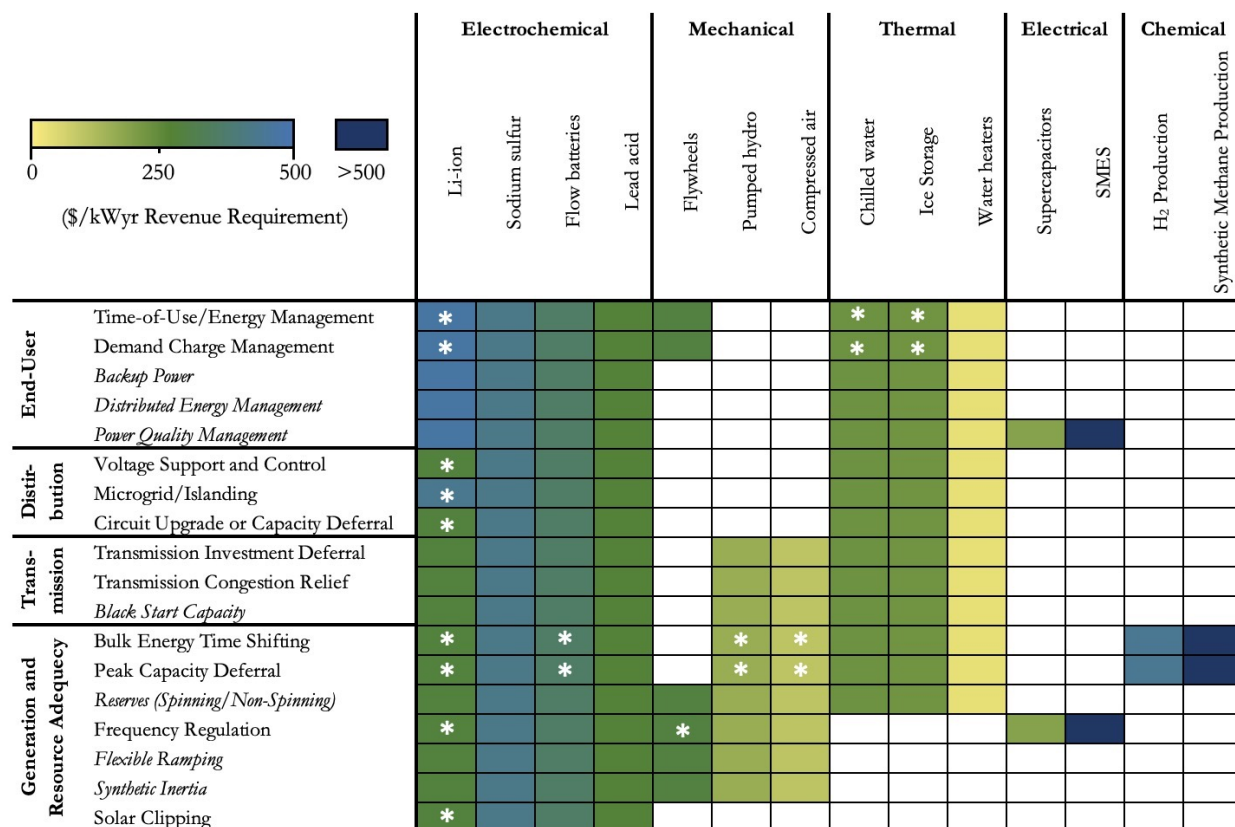
Table 1 describes the categories of storage-related services and applications that we analyzed. Additional details on each service and application is provided in Section 3 of the report.

**Table 1.** Categories of storage-related services and applications

<b>End-User Services</b>	Considers behind-the-meter applications associated with residential, commercial, and industrial customers to reduce charges associated with peak demand and time-of-use rates by shifting when electricity demand occurs
<b>Distribution</b>	Considers the use of storage to support the electricity distribution network, including reliability enhancement, capacity deferment, peak shaving, and voltage control
<b>Transmission</b>	Considers the use of storage to alleviate transmission congestion and defer new investments in transmission
<b>Generation and Resource Adequacy</b>	Considers the use of storage to charge using low-cost generation, and discharge during high marginal price periods, defer investment in peaking capacity, provide frequency regulation to ensure the supply of grid electricity is balanced minute-to-minute, and recover solar-generated electricity that would otherwise be clipped by an inverter

<sup>1</sup> <https://energy.ncsu.edu/storage/>

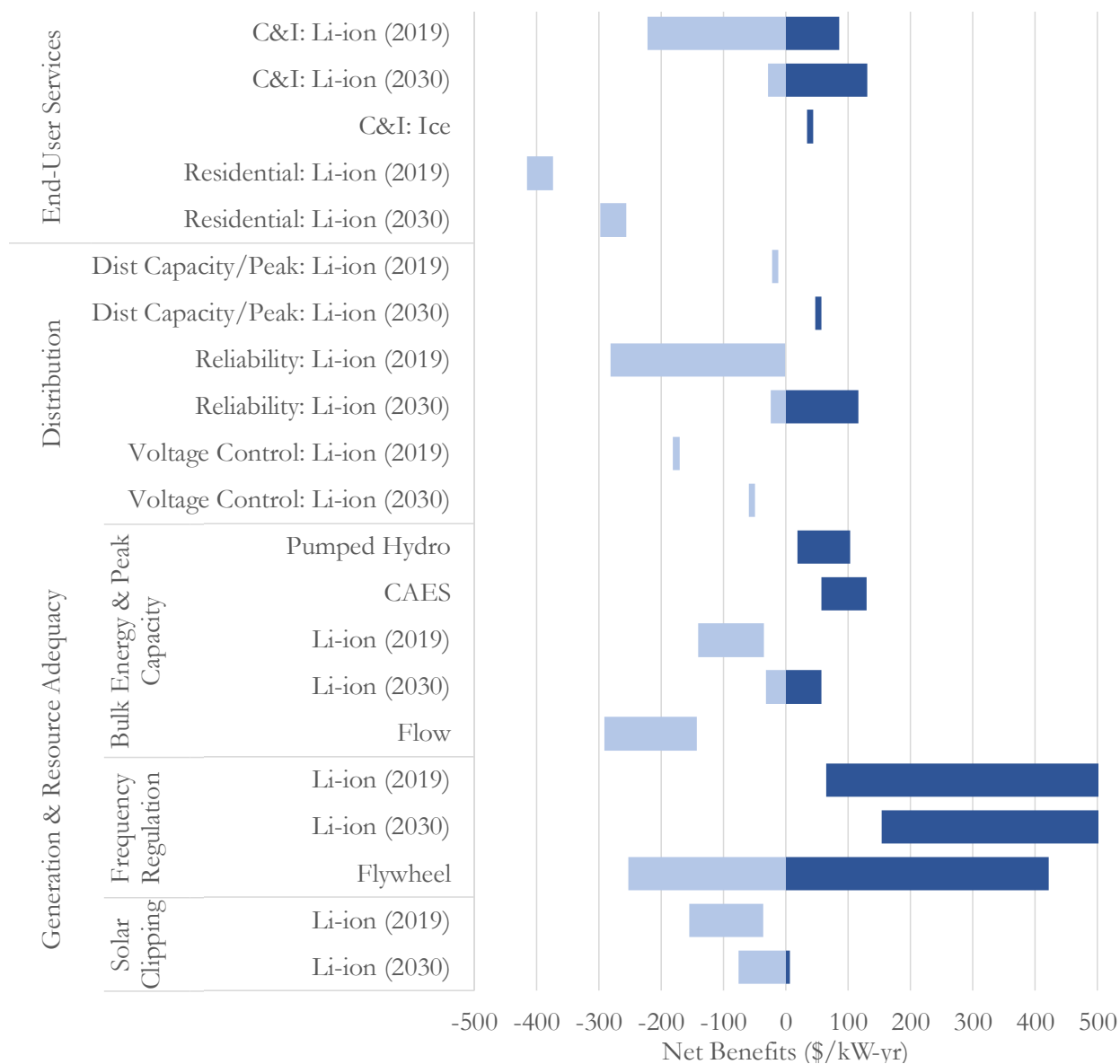
We analyzed the cost and performance of several storage technologies, guided by our working definition that requires the technology to store energy that “was once electrical energy.” This definition ensures that the storage technologies we analyzed are relevant to electricity grid operations, which is the focus of this study. Figure 1 shows the intersection between storage technologies and the services and applications they can serve. We assessed the cost and technical characteristics of all technologies listed, and performed formal benefit-cost analysis where indicated by the white asterisks. Italicized services were examined qualitatively, but no modeling was performed.



**Figure 1.** Intersection between storage technologies and grid-related services. The colors indicate the magnitude of the revenue requirement, which represents the fixed costs associated with the storage technology: capital cost amortized over the technology lifetime at a 10% rate plus annual fixed operations and maintenance costs. Higher revenue requirements do not necessarily imply lower cost-effectiveness, as more costly options may be able to capture greater benefits.

## Results

Figure 2 shows the range of net benefits associated with different storage technologies and applications. Given the rapid reductions in Li-ion battery prices, we analyze Li-ion batteries under both 2019 and projected 2030 costs. Projected cost reductions by 2030 shift many of the Li-ion battery scenarios to positive net benefits. Other technologies also present attractive opportunities. In the end user services category, ice storage is already cost-effective. Though highly sensitive to siting constraints, both pumped hydro and compressed air energy storage may be cost-effective options today for bulk energy time shifting and peak capacity deferral.



**Figure 2.** Range of net benefits (\$/kWyr) for each technology and service category analyzed. Light blue bars represent negative net benefits (i.e., costs exceed benefits), while dark blue bars represent positive net benefits (i.e., benefits exceed costs). Results assuming current Li-ion battery costs in 2019 and projected 2030 costs are presented separately. Note that Li-ion battery benefits for frequency regulation exceed \$500/kWyr, but are truncated for readability.

Key insights by service type are presented in the boxes below. Our aim here is not to be comprehensive, but rather to point out the most interesting insights, supported by our technical analysis.

### End User Services

- Using Li-ion batteries to reduce commercial and industrial (C&I) coincident peak (CP) and time-of-use (TOU) charges is currently cost-effective for some customers, with 2-hour duration batteries yielding the highest benefits. Anticipated price drops in Li-ion batteries will make this application attractive for more customers.
- Ice storage is currently cost-effective for C&I customers under CP and TOU rates. This result is consistent with the North Carolina market, where over 80 ice storage projects have been implemented.
- Residential battery storage coupled with a rooftop solar photovoltaics is not cost-effective under current electricity rate design.

### Distribution

- Price declines by 2030 are expected to make the use of Li-ion batteries to provide peak distribution capacity deferral and peak shaving at the substation as well as reliability enhancement attractive applications. Because conditions can vary widely, there are likely current cost-effective opportunities to deploy storage to improve performance on the most problematic distribution circuits.

### Bulk Energy Time Shifting and Peak Capacity Deferral

- For bulk energy time shifting and peak shaving, pumped hydro and compressed air energy storage (CAES) suggest cost-effectiveness today, but are highly constrained by site-specific conditions. The cost-effectiveness of pumped hydro is consistent with Duke Energy's decision to uprate the Bad Creek pumped storage facility in South Carolina, and Dominion's decision to pursue a new pumped hydro project in Virginia. New additions of pumped hydro are highly site-specific, so the cost numbers used here may not be applicable to new installations. CAES warrants further consideration, although research is required to determine whether the suitable geology exists in North Carolina to store the air.
- The use of Li-ion batteries is not cost-effective for bulk energy time shifting and peak generation capacity deferral when assuming 2019 battery costs. However, with projected costs in 2030, up to 5 GW of battery capacity may prove cost-effective for time shifting and peak shaving.
- With the continued expansion of solar generation in North Carolina, energy storage used for bulk energy time shifting and peak shaving consistently reduces system-wide carbon dioxide emissions.
- In a future with higher natural gas prices, the relative cost-effectiveness of energy storage for bulk energy time shifting increases significantly.
- Energy storage proves to be more cost-effective with higher solar penetrations because low marginal cost solar can be captured and time shifted.
- The capacity value assigned to energy storage, defined as the fraction of installed capacity that can be relied upon during peak demand periods, is a key determinant of its overall value.

### Frequency Regulation

- Among the services we studied, frequency regulation provides the highest net benefits and represents a key near-term opportunity for storage. Though we did not have the data to analyze frequency regulation in North Carolina, data from competitive markets (PJM and NYISO) provide a strong indication that batteries can cost effectively provide this service.
- Frequency regulation can be met cost-effectively by separating the regulation signal into fast changing components, which could be energy-neutral and supplied by energy storage, and the slow moving components, which can be supplied by conventional generators.

### Solar Clipping

- At current costs, DC-coupled batteries to reduce solar clipping are only cost-effective with significant value from renewable energy credits.
- The relatively flat marginal costs for electricity in North Carolina do not provide significant arbitrage opportunities for batteries to time shift the clipped solar energy.

Some of storage applications only require the energy storage device to be used for a small share of time, leaving it available to serve other end uses. Termed “stacked services” or “multitasking,” energy storage can be operated to serve multiple grid roles, increasing the revenue potential and likelihood of economic viability. We explicitly consider stacking together benefits associated with bulk energy time shifting and peak generation capacity deferral as well as distribution and generation capacity deferral. We also discuss the possibility of stacking benefits associated with solar clipping, bulk energy time shifting, and generation capacity deferral as well as stacking behind-the-meter, end user services with frequency regulation. Finally, our scenarios associated with bulk energy time shifting show consistent CO<sub>2</sub> emissions reductions in projected 2030 scenarios. Though those emissions are not currently assigned a monetary value, those emissions benefits can be stacked with benefits from all service categories.

### Market Size and Jobs

Integrated across all service categories, we envision the potential for storage capacity to exceed 1 GW by 2030. Particularly when considering Li-ion battery deployment, given its rapidly changing costs, it is critical to evaluate all near-term investment decisions to ensure that investments in conventional generation, transmission, and distribution capacity do not lock out the ability to invest in energy storage investments that would reasonably be expected to be more economical in the next several years.

Given high levels of uncertainty, we make no direct claim about the possibility for net job creation in North Carolina from the storage sector, though to the extent energy storage can be cost-effectively deployed to reduce the cost of generating, transmitting, and distributing electricity, it could spur some marginal economic growth and employment. Significant job creation is a possibility if North Carolina becomes a hub for innovation in storage technology, attracting storage-related firms to the state.



## Policy Options

The following menu of recommended policy options are a starting point for further deliberations between stakeholders and decision-makers in the development of a statewide coordinated energy storage policy. Options can be categorized into three separate categories, roughly corresponding to the magnitude of intervention: Prepare, Facilitate, and Accelerate. In the report that follows, we discuss potential elements that may be considered within each policy option, as well as examples from other states where such policies have been proposed or implemented. We believe that each option warrants further discussion and deliberation, but make no judgement on their relative merits. Stakeholders and decision-makers are advised to carefully evaluate the implications of the below options—and the subsequent design and implementation of those options—in the regulatory and market context of North Carolina.

### Prepare

The analyses conducted here suggest that some energy storage applications are already cost-effective or will be by 2030. The following recommendations are provided for consideration if stakeholders and decision-makers are interested in addressing potential gaps or areas of uncertainty that might otherwise hinder the deployment of cost-effective energy storage.

- Update and clarify planning provisions
- Update and clarify the definition and ownership of storage
- Evaluate net metering rules in relation to the utilization of storage
- Update interconnection rules
- Provide guidance for the updating and adoption of local codes and permitting standards

### Facilitate

The following recommendations are provided for consideration if stakeholders and decision-makers are interested in interventions that might help to either increase the value or decrease the cost of energy storage in the near-term.

- Develop competitive procurement process to monetize storage services
- Develop a standard offer program to monetize services provided by smaller projects
- Develop new tariff structures
- Create an expedited or streamlined interconnection process for behind-the-meter systems
- Promote data access and transparency
- Develop a targeted or expanded renewable energy portfolio standard (REPS) cost-recovery funding stream
- Establish a procurement goal

### Accelerate

Experience in other states demonstrates the influence of targeted policy on the deployment of energy storage. The following policy recommendations are provided for consideration if stakeholders and decision-makers wish to increase the pace of energy storage deployment.

- Develop storage-specific incentives
- Incorporate storage within the North Carolina REPS
- Develop a clean peak standard
- Establish a procurement requirement

## 1. Introduction and Motivation

North Carolina’s power sector faces a rapidly increasing penetration of renewable energy as well as economic and environmental pressures to decrease coal-fired electricity production (Nelson and Liu, 2018). Energy storage may present an attractive solution to ensure reliable service, decrease costs to rate payers, and reduce the environmental impacts of electricity production. Given the complexity of grid operations, however, the impacts of using energy storage to achieve these goals should be rigorously evaluated. The NC General Assembly passed HB589, titled “Competitive Energy Solutions for NC,” and it was signed into law by Gov. Cooper in July 2017. Part XII, Section 12 requires the North Carolina Policy Collaboratory to undertake a study on energy storage technology and its potential benefit to NC consumers (see inset).

This report fulfills the requirements outlined in the study. The study team includes faculty, staff, and students from NC State University and NC Central University, spanning engineering, economics, and public policy. We have embarked on a comprehensive review of grid-related services that energy storage can fulfill, conducted techno-economic assessments of relevant storage technologies, performed benefit-cost analyses to determine where storage can provide significant

value in both stand-alone and stacked cases, examined the current business, regulatory, and legal framework in which these technologies would need to find their footing, and identified potential policy options to help enable the cost-effective adoption of storage within North Carolina. To assist with our efforts, we have engaged numerous stakeholders through multiple public meetings in addition to bilateral meetings with interested parties (see Appendix A for stakeholder participants). Through these meetings, we have shared our approach, data, models, and insights. In return, we have received valuable stakeholder feedback that has helped to shape and improve the analysis contained within this report.

The overarching goal of the study – motivated by the legislative language – is to identify opportunities to deploy storage that benefit North Carolina consumers. To meet this goal, we maintain the broadest possible scope, within the limits afforded by time and budget. To help focus our efforts early in the project, we developed the following working definition of an energy storage system:

“a system used to store electrical, mechanical, chemical, or thermal energy that was once electrical energy, for use in a process that contributes to end-user demand management or grid operation and reliability.”

### **PART XII. ENERGY STORAGE STUDY**

**SECTION 12.** The North Carolina Policy Collaboratory (Collaboratory) at the University of North Carolina at Chapel Hill shall conduct a study on energy storage technology. The study shall address how energy storage technologies may or may not provide value to North Carolina consumers based on factors that may include capital investment, value to the electric grid, net utility savings, net job creation, impact on consumer rates and service quality, or any other factors related to deploying one or more of these technologies. The study shall also address the feasibility of energy storage in North Carolina, including services energy storage can provide that are not being performed currently, the economic potential or impact of energy storage deployment in North Carolina, and the identification of existing policies and recommended policy changes that may be considered to address a statewide coordinated energy storage policy. The Collaboratory shall provide the results of this study no later than December 1, 2018, to the Energy Policy Council and the Joint Legislative Commission on Energy Policy.

This definition focuses our efforts on the use of storage technologies that interact with the electricity grid, either directly or indirectly. We also examine the cost-effectiveness of storage technologies under different scenarios. Given the rapidly changing electricity generation mix and declining battery costs (particularly lithium-ion), we perform benefit-cost analysis that considers opportunities in today's system as well as in 2030.

The report is organized as follows. Section 2 provides a snapshot of the current energy storage market in the United States. Section 3 identifies the various grid-related services and applications that can be fulfilled with energy storage. In addition, we provide a rationale for which services we analyze in this report. In Section 4, we provide a review and techno-economic assessment of relevant energy storage technologies. Section 5 identifies the compatible set of services and energy storage technologies, and provides an overview of our approach to this analysis. Section 6 includes the background, methods, and analysis results for each grid-related service. Section 7 synthesizes the findings across the different service categories, estimates the potential storage market size through 2030, and evaluates the possibility of value stacking applications to increase the benefits of energy storage. Section 8 discusses the job implications associated with storage deployment. Section 9 includes a detailed assessment of policy in both North Carolina and nationally, and concludes with key insights and recommendations to help North Carolina fully realize and deliver the benefits of energy storage to NC consumers. Section 10 describes high priority areas for future work.

**A note on our approach.** Our approach to this study has been informed by two key factors: (1) the storage market is rapidly changing, and (2) transparency in analysis helps to engender trust among stakeholders. To address these two points, we have endeavored to use publicly available data and models in order to ensure transparency in our efforts. Where possible, we have made the models and data publicly available for use by others on the project website. In addition to building trust through transparency, we hope that access to models and data allows for third party experimentation that extends the value of the project. Following a more academic style, we have embedded references throughout, allowing readers to follow-up on assertions within the report. Finally, this report is intended to communicate our audience to different audiences. For example, Section 6 includes detailed technical analysis for those who are interested in our analytical approach, data sources, and service-specific insights. By contrast, Section 7 and the executive summary provide a succinct overview of our findings for those interested in the high-level insights.

## References

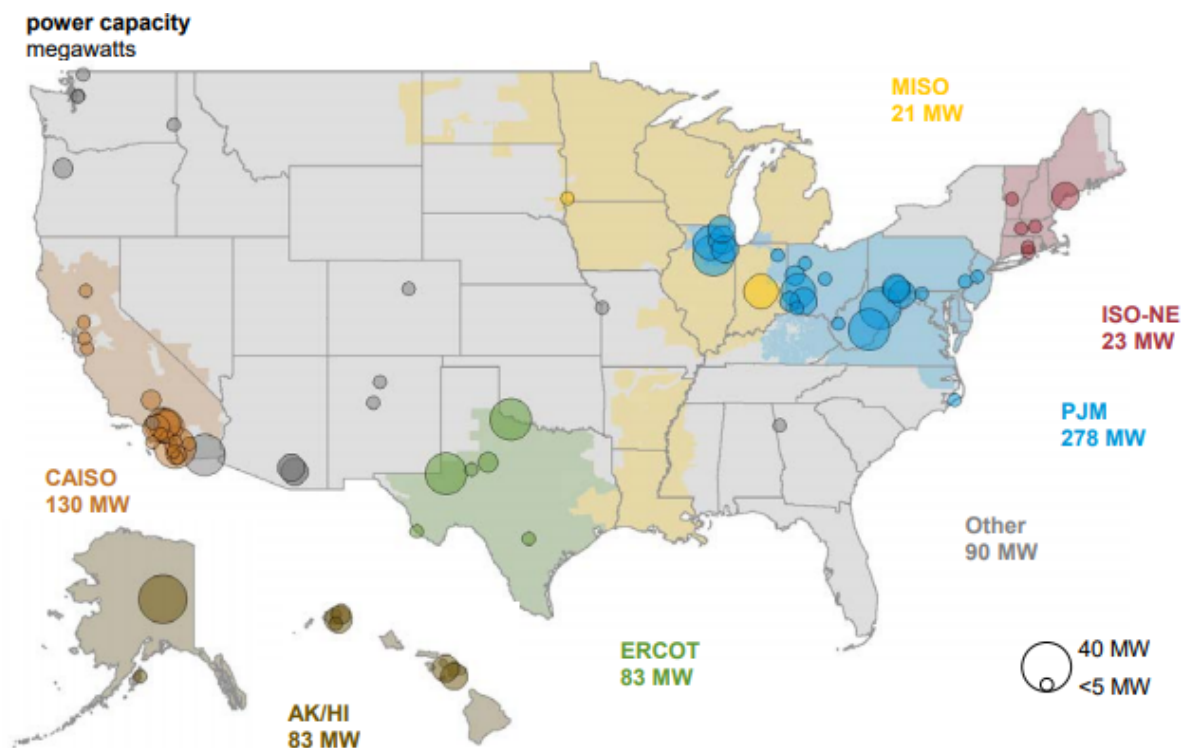
Nelson, W., and S. Liu. "Half of U.S. Coal Fleet on Shaky Economic Footing: Coal Plant Operating Margins Nationwide." Bloomberg New Energy Finance, 2018.

## 2. Current Status of Energy Storage Deployment

According to GTM Research and the Energy Storage Association (2018), 1.08 Gigawatt-hours (GWh) of energy storage was deployed in the U.S. between 2013 and 2017. While front-of-the-meter projects account for the majority of this capacity, behind-the-meter storage deployment is increasing. In Q1 2018, behind-the-meter residential and non-residential installations accounted for 63% of the MW and 49% of the MWh deployed (GTM Research and ESA, 2018). Furthermore, approximately the same amount of residential energy storage capacity was installed in Q1 2018 as front-of-the-meter storage capacity. Similarly, the Smart Electric Power Alliance found that between 2016 and 2017, residential storage deployment increased by over 200% (in MW), while non-residential deployment increased 9% and front-of-the-meter (utility-scale) deployment decreased by 3% (SEPA, 2018).

### 2.1. Top State Energy Storage Markets

While energy storage deployment is quickly increasing in the U.S., these projects tend to be concentrated in particular regions or states. In 2017, the Energy Information Administration found that the PJM market region led deployment with 278 MW installed, followed by the California ISO region (130 MW), all other continental U.S. regions (90 MW), ERCOT and Alaska/Hawaii (83 MW), MISO (21 MW), and ISO-New England (23 MW) (EIA, 2018).



**Figure 2.1** Energy storage deployment across the United States in 2017 (U.S. EIA, 2018).

California is currently the leading state for energy storage deployment, with at least 296.6 MW (770.6 MWh) installed (SEPA, 2018). This is due in large part to the state's 1,325 MW energy storage procurement target and the Self-Generation Incentive Program, which provides rebates for both residential and commercial energy storage projects.

Hawaii is another leader in energy storage deployment, with at least 35.6 MW (80.8 MWh) installed (SEPA, 2018). Hawaii's unique position as an island and high electricity rates have contributed to storage deployment in the state, along with new customer compensation options for solar-plus-storage systems.

Arizona is a strong state for energy storage deployment, with 26.4 MW (13.3 MWh) of installed capacity (SEPA, 2018). The Arizona Corporation Commission established a temporary moratorium on new natural gas generation, and recently revised utility planning procedures to more fully consider energy storage.

Texas' energy storage market is growing, largely due to battery systems being installed at existing wind energy facilities (SEPA, 2018). Texas has 88.7 MW (103.4 MWh) of installed energy storage capacity (SEPA, 2018).

## **2.2. North Carolina Energy Storage Market**

In North Carolina, approximately 1 MW of battery storage capacity has been deployed (DOE, 2018 and SEPA, 2018). Ice thermal storage is much more prevalent in the state, with over 80 projects currently deployed, the majority of which are located at schools (NCSEA, 2018). Hiwassee Dam, a pumped hydroelectric storage project owned and operated by the Tennessee Valley Authority (TVA), is also in use in the state, providing approximately 185 MW of capacity (NCSEA, 2018). Though not in North Carolina, Duke Energy also operates two large pumped hydro facilities in South Carolina – Bad Creek and Jocassee – that both serve the Carolinas. Bad Creek is being upgraded from approximately 1000 MW to 1400 MW, in part to help balance the influx of solar within North Carolina (Kenning, 2016). Several additional battery storage projects are planned in the state, including 12 MWh of battery storage facilities coupled with solar photovoltaic projects for Brunswick Electric Membership Corporation (Cypress Creek Renewables, 2018) and a 500 kW battery storage facility paired with a 1 MW solar PV project for Fayetteville Public Works Commission (FPWC, 2017). Duke Energy also announced in October 2018 that it would be investing \$500 million in battery storage (approximately 300 MW of capacity) in the Carolinas over the next 15 years (Duke Energy, 2018). Figure 2.1 provides the location and type of existing energy storage facilities in the Southeastern U.S.

## **2.3. Energy Storage Market Projections**

GTM Research projects that the U.S. energy storage market will grow by a factor of 17, in terms of capacity, from 2017 to 2023 (GTM Research, 2018). GTM estimates that in 2023, 47% of deployments will be residential and non-residential behind-the-meter installations, with the remainder being front-of-the-meter projects. Bloomberg New Energy Finance predicts that the global energy storage market will double six times by 2030 to reach a cumulative 305 GWh, with 25% of deployments being in the U.S. (Bloomberg, 2017).

State energy storage markets vary significantly and continue to be driven by state policies. Five states – California, Massachusetts, New Jersey, New York, and Oregon – currently have energy storage procurement targets. These targets are as follows: California – 1,325 MW by 2020; Massachusetts – 1,000 MWh by 2025; New Jersey – 2,000 MW by 2030; New York – 1,500 MW by 2025, and Oregon – 15 MWh by 2020. Some utilities have also developed plans to deploy significant amounts of energy storage. For example, the integrated resource plan of Public Service Company of Colorado (d/b/a Xcel Energy), approved in August 2018, includes 225 MW of energy storage.

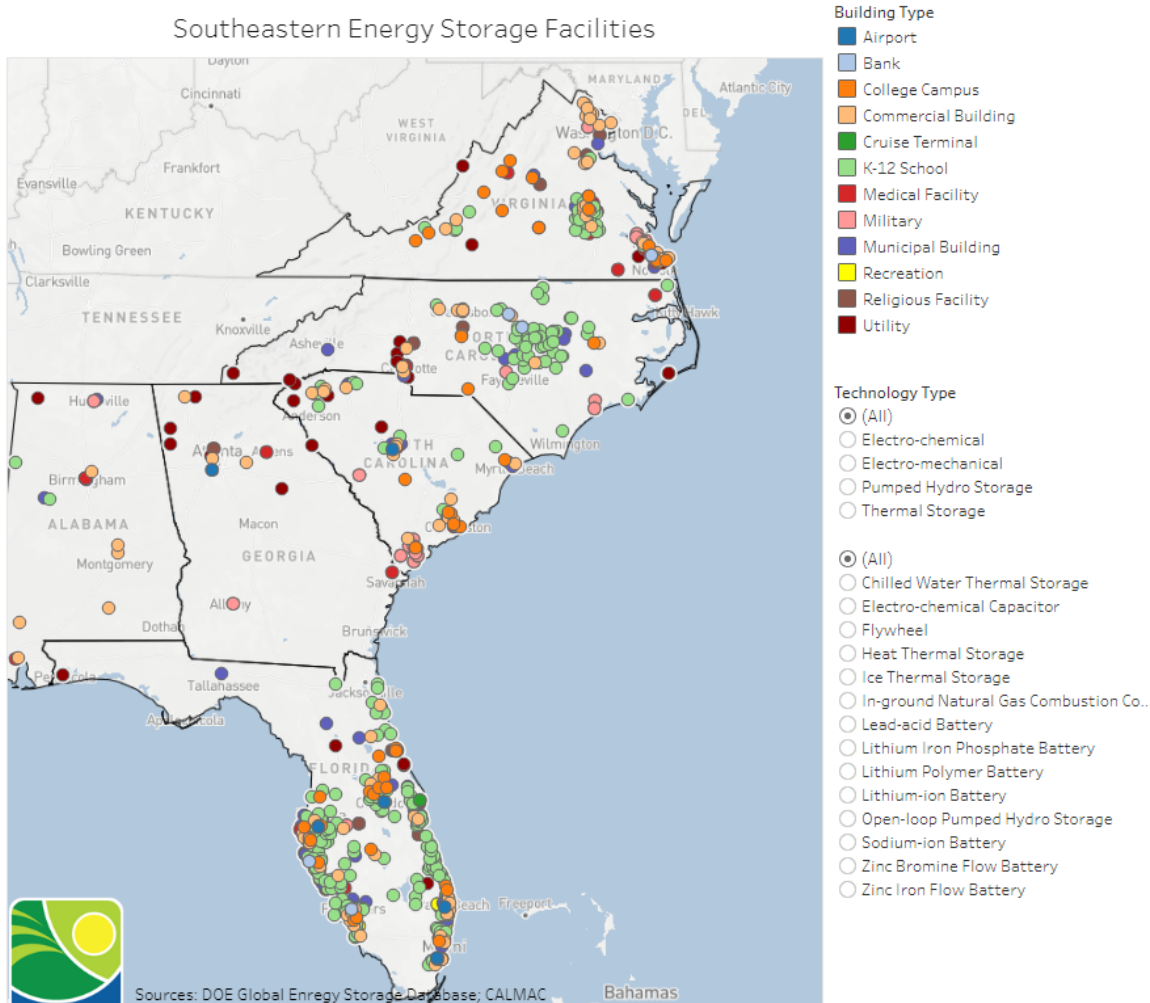


Figure 2.2. Energy storage facilities across the Southeastern United States (NCSEA, 2018).

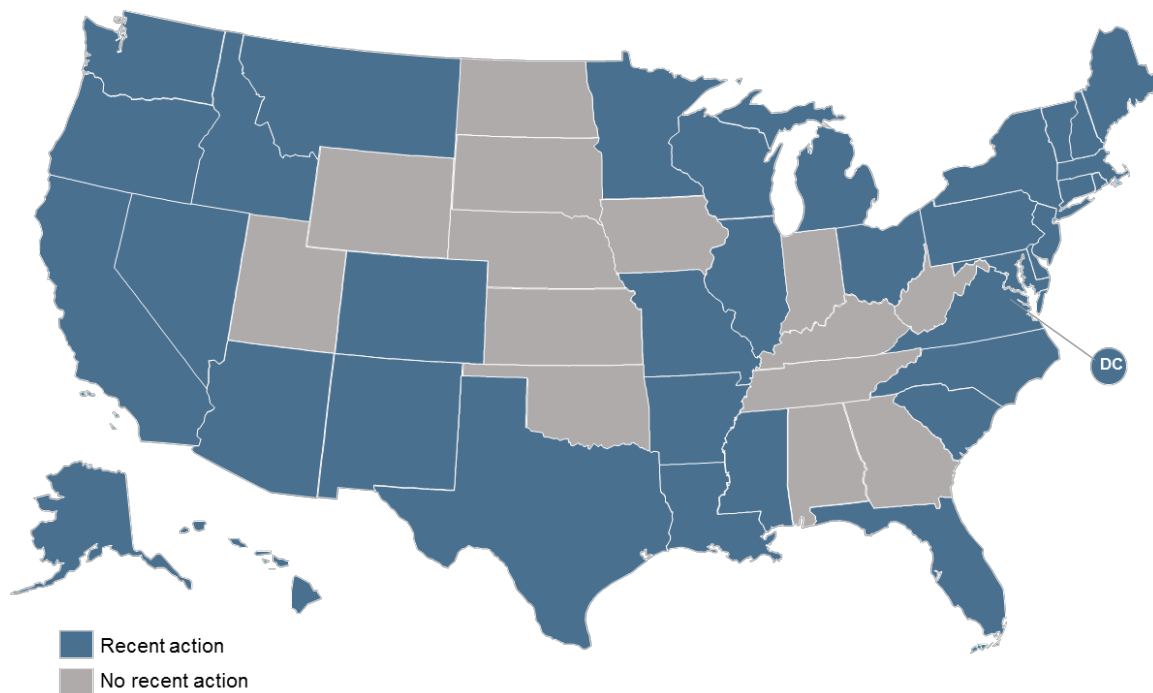
## 2.4. Federal Energy Storage Policy Overview

Energy storage deployment in the U.S. has been – and continues to be – highly policy dependent, with policy and regulatory attention to storage quickly increasing. At the federal level, the primary drivers of energy storage development are the investment tax credit and Modified Accelerated Cost Recovery System (MACRS), both available to battery storage facilities paired with renewable energy systems to different extents based on the degree to which the battery is charged with renewable energy (NREL, 2018). The Public Utility Regulatory Policies Act can also facilitate energy storage deployment, depending on state implementation, and the Federal Energy Regulatory Commission is addressing energy storage in multiple ongoing proceedings.

## 2.5. State Energy Storage Policy Overview

At the state level, policymakers and regulators are addressing energy storage in many different ways. Since January 2017, at least 36 states considered policy or regulatory changes related to energy storage (NCCETC, 2018). (See Figure 2.3.) One way that several states are beginning to address storage is with formal studies, such as those undertaken in Massachusetts, Vermont, and Maryland

(see Table 2.1). Other states are undertaking broader investigatory proceedings related to electric grid modernization, which include consideration of energy storage.



**Figure 2.3.** Recent legislative and regulatory action on energy storage (NCCETC, 2018).

State regulators are also revising resource planning processes in order to more fully evaluate energy storage options and undertaking distribution system planning efforts to identify locations on the grid where energy storage and other distributed energy resources may provide greater or lesser value. Policymakers and regulators are also examining interconnection standards and distributed energy resource compensation rules to clarify their application to energy storage systems. Policymakers in other states are taking steps to directly grow the energy storage market by proposing new incentive programs, such as those in Maryland and Nevada, and energy storage procurement targets, such as those in California and Massachusetts. Section 9 of the report provides more detail on state-level policy and regulation.

Table 2.1. State-initiated energy storage studies.

State	Origin	Directive	Timeline	Results
MD	<a href="#">H.B. 773</a> (Enacted May 2017)	H.B. 773 directed the Maryland Power Plant Research Program to conduct a study of regulatory reforms and market incentives that are necessary or beneficial to increase the use of energy storage devices in the state. The Program is to consult with stakeholders to conduct the study.	Began July 2017; Due December 2018	Initial findings, published in January 2018, discuss stakeholder perspectives on obstacles to storage deployment and a wide variety of policy recommendations.
MA	Governor	The study was intended to examine the national and state storage industry landscape, economic development and market opportunities for storage in the state, and potential policies and programs to support storage deployment. The study was to provide policy and regulatory recommendations along with a cost-benefit analysis.	Published September 2016	Recommended a goal of 600 MW of advanced energy storage by 2025, which the authors estimate would result in \$800 million in system benefits to ratepayers. The Department of Energy Resources subsequently established a 200 MWh by 2020 target. Legislation enacted in August 2018 established a 1,000 MWh by 2025 target.
NV	<a href="#">S.B. 204</a> (Enacted May 2017)	S.B. 204 directed the Public Utilities Commission of Nevada to determine whether it is in the public interest to establish an energy storage procurement target.	Published October 2018	Study finds that by 2020, 175 MW of utility-scale battery storage can be deployed cost-effectively, increasing to 700 MW – 1,000 MW by 2030. Behind-the-meter storage capacity could add up to 300 MW by 2030.
NJ	<a href="#">A.B. 3723</a> (Enacted May 2018)	A.B. 3723 directs the Board of Public Utilities and PJM Interconnection to work with stakeholders to conduct an analysis examining how storage can provide benefits to ratepayers and promote electric vehicles; types of storage technologies; the benefits and costs to ratepayers, local governments, and utilities; the optimal amount of energy storage to add in the state over the next five years to maximize ratepayer benefits; the optimal locations for distributed energy resources; and the cost to ratepayers of adding the optimal amount of storage. The study is to quantify potential benefits and costs of increasing storage in the state and provide recommendations to increase storage opportunities, including financial incentive recommendations.	Due May 2019	Study has not yet been completed. A.B. 3723 established a 2,000 MW by 2030 energy storage target. Following the study, the Board of Public Utilities is to develop a process and mechanism for achieving the target.
NY	Governor	Developed by the Department of Public Service and New York State Energy Research and Development Authority to plan an approach and make recommendations to achieve Governor Cuomo's 1,500 MW energy storage target.	Target announced January 2018; Published June 2018	Identifies policies, regulations, and initiatives that will help meet the Governor's statewide energy storage target of 1,500 MW by 2025.
NC  NC (cont'd)	<a href="#">H.B. 589</a> (Enacted July 2017)	H.B. 589 directed the North Carolina Policy Collaboratory to study how energy storage technologies may or may not provide value to North Carolina consumers. The study was to address the feasibility of storage in the state, the economic potential or impact of storage deployment, and recommended policy changes that may be considered.	Began December 2017; Due December 2018	Detailed in this report.
VT	<a href="#">Act 53</a> (Enacted)	Act 53 directed the Department of Public Service to prepare a report on deploying energy storage on Vermont's transmission and	Published October 2017	Recommended that in the short term, utilities include storage analyses in integrated resource planning and in the



	May 2017)	distribution system. The report was to examine actions affecting energy storage deployment; federal and state jurisdictional issues; opportunities for, benefits of, and barriers to energy storage deployment; regulatory options and structures that can foster energy storage; and potential methods for fostering the development of cost-effective energy storage and the benefit and cost impacts on ratepayers.		long term, the Department of Public Service should evaluate cost-benefit methodologies to create a more concrete framework for utility evaluation of storage. Recommends, in the longer term, utilizing locational value in rate design. Does not recommend any changes to interconnection rules and recommends against adoption of a storage procurement target at this time.
VA	<a href="#">H.B. 5002</a> (Enacted June 2018)	H.B. 5002, the 2018 Budget Bill, directs the Virginia Solar Development Authority and Department of Mines, Minerals, and Energy to conduct a study to determine whether or not legislation adopting regulatory reforms and incentives will be helpful in encouraging emerging energy storage capacity in the state.	Awarded Contract November 2018; Due September 2019	Study has not yet been completed.

## References

DOE Global Energy Storage Database, U.S. Department of Energy, Accessed October 2018, <https://www.energystorageexchange.org/>

Duke Energy to invest \$500 million in battery storage in the Carolinas over the next 15 years, Duke Energy, October 2018, <https://news.duke-energy.com/releases/duke-energy-to-invest-500-million-in-battery-storage-in-the-carolinas-over-the-next-15-years>

Global Storage Market to Double Six Times by 2030, Bloomberg New Energy Finance, November 2017, <https://about.bnef.com/blog/global-storage-market-double-six-times-2030/>

GTM Research and Energy Storage Association, U.S. Energy Storage Monitor: Q2 2018 Executive Summary, June 2018, <http://energystorage.org/news/esa-news/us-residential-energy-storage-market-hits-new-highs-q1-2018>

Federal Tax Incentives for Energy Storage Systems, National Renewable Energy Laboratory, January 2018, <https://www.nrel.gov/docs/fy18osti/70384.pdf>

Kenning, 2016. Duke Energy to expand South Carolina pumped hydro facility by 200MW. Energy Storage News, September 12, 2016. <https://www.energy-storage.news/news/duke-energy-to-expand-south-carolina-pumped-hydro-facility-by-200mw>

Lockheed Martin Delivers Energy Storage Systems to Cypress Creek Renewables for Solar-Plus-Storage Projects, Cypress Creek Renewables, April 2018, <https://ccrenew.com/news/lockheed-martin-delivers-energy-storage-systems-to-cypress-creek-renewables-for-solar-plus-storage-projects/>

Request for Qualifications – Design-Build Services – Community Solar and Energy Storage Project, Fayetteville Public Works Commission (FPWC), October 2017, [http://www.faypwc.com/wp-content/uploads/2015/06/bid-rfq-design-build-services-community-solar-energy-storage-project\\_101717.pdf](http://www.faypwc.com/wp-content/uploads/2015/06/bid-rfq-design-build-services-community-solar-energy-storage-project_101717.pdf)

Southeastern Energy Storage Facilities Map, North Carolina Sustainable Energy Association, Accessed August 2018, <https://energync.org/maps/>

Utility Energy Storage Market Snapshot, Smart Electric Power Alliance, August 2018,  
<https://sepapower.org/resource/2018-utility-energy-storage-market-snapshot/>

U.S. Battery Storage Market Trends, U.S. Energy Information Administration, May 2018,  
[https://www.eia.gov/analysis/studies/electricity/batterystorage/pdf/battery\\_storage.pdf](https://www.eia.gov/analysis/studies/electricity/batterystorage/pdf/battery_storage.pdf)

### 3. Storage Applications and Services

Several studies have catalogued and characterized the range of services that can be provided by energy storage systems (e.g., Akhil et al., 2013; ESA 2018; Fitzgerald et al., 2015; Massachusetts, 2016; Stanfield, 2017; Vermont, 2017; Byrne, 2012). While there are different ways to categorize the services provided, we have chosen to do so in a way that makes the most sense in a North Carolina context. At the highest level, we distinguish between behind-the-meter and in-front of the meter services. We refer to behind-the-meter services as end-user services; in-front services include distribution services, transmission services, and generation and resource adequacy. We provide a comprehensive list of services under these categories, and prioritize key services for quantitative analysis based on their relevance within North Carolina. Also, it is important to note that some of these grid-related services are not explicitly procured or valued, but are needed for the reliable and safe operation of the grid.

Some of these services can be stacked in order to increase the overall value stream, but the viability of providing multiple services depends on the location (i.e., behind-meter, distribution, transmission), technology type, prevailing policy, and the value of each service. In Section 7, we describe the viability of stacking services.

#### 3.1 End User Services

In this section, we provide a list of energy storage services that can directly benefit end-users, which include residential, commercial, and industrial customers.

##### 3.1.1 Time-of-Use/Energy Management

Energy storage is able to shift the net load of customers to take advantage of time-of-use (TOU) pricing or other incentives by adjusting when electricity from the grid is consumed.

##### 3.1.2 Demand Charge Management

Shifting electricity consumption to reduce the customer's highest *peak* consumption from the grid can reduce demand charges (\$/kW). These are especially significant for industrial and commercial customers. These charges can be based on the end-user's electricity usage coincident with the system peak or the end-user's highest electricity usage during a billing period.

##### 3.1.3 Backup Power

Aside from reducing electricity bills, storage can provide emergency backup power in the event of outages. During power outages, energy storage can provide power to an end user-user disconnected from the electrical grid. Because this service is likely to benefit a limited number of owners rather than a large base of North Carolina consumers, we do not analyze the benefits of backup power from storage. However, we do analyze the benefits of using storage to enhance reliability on the distribution circuit, as described below.

### **3.1.4 Power Quality Management**

Particularly for industrial customers who require highly conditioned power, energy storage can enable facility interaction with the grid to reduce reliance on and disturbance of power quality, including voltage fluctuation, voltage drop, and frequency variation. Since this application benefits a limited set of owners rather a large base of North Carolina consumers, we do not analyze the benefits of power quality management.

## **3.2 Distribution Services**

In this section, we provide a list of energy storage applications that provide distribution-level services. A distribution circuit provides the connection between a high-voltage transmission system and low-voltage electric customers.

### **3.2.1 Voltage Support and Control**

Energy storage can provide voltage support and control to ensure the reliability of the local distribution circuit. Storing energy can be used to smooth voltage flicker due to distributed generation and load variability, thereby maintaining voltage within industry limits across distribution circuits. In addition, voltage support and control reduces wear and tear on capital intensive devices, such as load tap changers, voltage regulators, capacitors, and increases their useful lifeline.

### **3.2.2 Reliability Enhancement**

Similar to backup power for end-use customers, energy storage can be used to support microgrid islanding during power outages either as the main source of energy or to support operation of other DERs. Additionally, energy storage can support microgrids with participation in economic dispatch or price responsive demand programs.

### **3.2.3 Capacity Deferral and Peak Shaving**

Energy storage can reduce the need for circuit upgrades to meet peak demands for a small number of hours each year. Capacity deferral and associated peak shaving involves using storage to control peak demand at the distribution circuit level in order to defer an expensive bulk capacity upgrade and also achieve associated monthly peak shaving. Storage can be utilized to defer substation upgrades, distribution feeder upgrades, reduce peak demand, and help to support operation of the sub-transmission and transmission systems.

## **3.3 Transmission Services**

In this section, we provide a list of energy storage applications that provide transmission-level services that reduce investment in new or upgraded transmission lines or reduce the constraints of transmission on the cost of operation.

### **3.3.1 Transmission Investment Deferral**

Energy storage can reduce or defer the need for transmission build out. Energy storage can provide additional capacity in locations which might otherwise require additional transmission capacity to serve load a few hours per year. This use of storage can also reduce overloading of transmission lines and transformers, which increases equipment lifetime.

### **3.3.2 Transmission Congestion Relief**

Energy storage located at the transmission level can relieve congestion over certain periods of the year and allow more economic generators or renewable generators to produce more energy. Relieving congesting allows for more economic (i.e., less expensive) generators to be used more frequently, and avoids the curtailment of renewable generators when congestion is high.

## **3.4 Generation and Resource Adequacy Services**

In this section, we provide a list of energy storage applications that provide generation and resource adequacy services.

### **3.4.1 Peak Capacity Deferral**

Peak generation capacity requirements can be decreased by utilizing energy storage during peak demand periods. Energy produced at lower demand periods can be stored and injected at higher demand periods to avoid generation capacity expansion and peaker plant operation. The firm capacity that energy storage can provide is related closely to the energy to power ratio of the storage device. When directly coupled, energy storage can be used to increase the capacity value of variable generation resources.

### **3.4.2 Bulk Energy Time Shifting**

In addition to peak capacity deferral, energy storage can be used to shift the timing of electricity production. Energy storage can be charged when marginal production costs are low, and dispatched when marginal production costs are high.

### **3.4.3 Frequency Regulation**

Primary and secondary frequency regulation and emergency frequency response can be provided by energy storage. Energy storage technologies with quick ramp rates can follow a real-time signal or the area control error (ACE) for primary frequency regulation, or the longer timeframe scheduling (minutes) of secondary frequency regulation. The ramping ability of some energy storage technologies also allows emergency frequency response to reduce the initial frequency drop in contingency scenarios and support a return to the 60 Hz operating point. Energy storage providing these services avoids wear and tear on thermal generators and the lower efficiencies associated with ramping output.

### **3.4.4 Reserves (Spinning/Non-Spinning)**

Energy storage can be used as spinning and non-spinning reserves to respond to contingency events and correct for large imbalances between electricity supply and demand. The rapid start-up time and ramp rate of energy storage makes it eligible for spinning reserves, which can respond to sudden contingencies and give non-spinning reserves time to come online over longer time frames. Energy storage can provide reserves required to hedge uncertainty in load and variable generator forecasts. We do not examine the value of storage providing reserves in this study. Modeling the value of reserves would require more detailed data and models than we have available. In particular, separating the value of reserve services from the value of bulk energy time shifting and peak capacity in system operation is difficult without established methods.

### 3.4.5 Black Start Capacity

In the event of bulk system blackouts, storage systems that can store energy for long periods of time can be used as black start units. These units or parts of their capacity are set aside as part of a plan to restart the grid in the case of a system-wide black out. Primarily, pumped-hydro plants are used for this purpose because of the ease of storing water in reservoirs for long periods of time and starting the generators with minimal external electricity. We do not examine black start capacity in this study because of the small required resource size and limited applicability to most storage technologies apart from pumped hydro.

### 3.4.6 Flexible Ramping

While not a conventional product in electricity markets, energy storage reduces the need for thermal generators to ramp as quickly in response to diurnal demand profiles and variable generation from solar and wind power. Reducing the ramp rate needed for thermal generators allows the capacity needed to reach peak demand to come on earlier and ramp more slowly to meet the peak demand. Slower ramping allows for more efficient generation and generators with longer minimum startup and shutdown times to participate. We do not consider flexible ramping in this study because it has only been considered as a electric system product in recent years. Currently, CASIO is the only system operator that has defined the product and created a market for this grid service (CAISO, 2018).

### 3.4.7 Synthetic Inertia

While energy storage devices have no physical inertia, control systems can be used to provide fast responses that mimic inertia responses of generators. Inertia provided by conventional thermal generators reduces the rate of frequency fluctuations due to the mismatch between produced and demanded real power. Higher penetrations of renewable energy lead to lower system inertia and may require additional sources of inertia. This service is often overlooked because thermal generators, especially coal, have provided these services by default. The need for synthetic inertia is required when the share of variable renewables is high. For example, Eirgrid, the transmission system operator in Ireland, has a non-synchronous generation limit of 65% to avoid issues with frequency response and frequency deviation during contingency events (Eirgrid, 2017). While several storage technologies can fulfill this service, it is less likely to be required over the timeframe of this analysis. As a result, we do not analyze synthetic inertia.

## References

Akhil, Abbas A., Georgianne Huff, Aileen B. Currier, Benjamin C. Kaun, Dan M. Rastler, Stella Bingqing Chen, Andrew L. Cotter, Dale T. Bradshaw, and William D. Gauntlett. 2013. DOE/EPRI 2013 Electricity Storage Handbook in Collaboration with NRECA. Sandia National Laboratories Albuquerque, NM.

CAISO, 2018. "Flexible Ramping Product."

<http://www.caiso.com/informed/Pages/StakeholderProcesses/CompletedClosedStakeholderInitiatives/FlexibleRampingProduct.aspx>. Accessed on 15 October 2018.

"Decision on Multiple-Use Application Issues ( Proposed Decision Rev. 3)." 2018.

<http://docs.cpuc.ca.gov/PublishedDocs/Published/G000/M204/K478/204478235.pdf>.

Eirgrid, 2018. Operational Constraints Update 15/03/2017. Source: [http://www.eirgridgroup.com/site-files/library/EirGrid/OperationalConstraintsUpdateVersion1\\_50\\_March\\_2017\\_Final.pdf](http://www.eirgridgroup.com/site-files/library/EirGrid/OperationalConstraintsUpdateVersion1_50_March_2017_Final.pdf). Accessed on 6 October 2018.

Fitzgerald, Garrett, James Mandel, Jesse Morris, and Herve Touati. 2015. “The Economics of Battery Energy Storage.” Rocky Mountain Institute. <https://www.rmi.org/wp-content/uploads/2017/03/RMI-TheEconomicsOfBatteryEnergyStorage-FullReport-FINAL.pdf>.

Massachusetts Department of Energy Resources; Massachusetts Clean Energy Center. “State of Charge: Massachusetts Energy Storage Initiative.” Massachusetts Department of Energy Resources; Massachusetts Clean Energy Center, 2016. <https://www.mass.gov/service-details/energy-storage-study>.

Stanfield, Sky, Joseph Petta, and Sarah Auck. “Charging Ahead: An Energy Storage Guide for Policymakers.” Interstate Renewable Energy Council, April 2017. [http://www.irecusa.org/wp-content/uploads/2017/04/IREC\\_Charging-Ahead\\_Energy-Storage-Guide\\_FINALApril2017.pdf](http://www.irecusa.org/wp-content/uploads/2017/04/IREC_Charging-Ahead_Energy-Storage-Guide_FINALApril2017.pdf).

Vermont Dept. of Public Service. “Vermont Energy Storage Study,” 15 November, 2017. [http://publicservice.vermont.gov/sites/dps/files/documents/Pubs\\_Plans\\_Reports/Energy\\_Storage\\_Report/Storage\\_Report\\_Final.pdf](http://publicservice.vermont.gov/sites/dps/files/documents/Pubs_Plans_Reports/Energy_Storage_Report/Storage_Report_Final.pdf).

Byrne, Raymond H., Matthew K. Donnelly, Verne W. Loose, and Daniel J. Trudnowski. “Methodology to Determine the Technical Performance and Value Proposition for Grid-Scale Energy Storage Systems.” Sandia National Laboratories, December 2012. <http://www.sandia.gov/ess/publications/SAND2012-10639.pdf>.

## 4. Storage Technology Assessment

There is a wide array of energy storage technologies available today, spanning early stage development to commercially available. Guided by the definition of energy storage provided in Section 1 of this report, we have focused our analysis on technologies that store what was once electrical energy and use it in a way that contributes to end-use management of electricity demand or grid operation and reliability. This broad definition allowed us to consider an extensive array of storage technologies. However, we do not claim that our assessment is comprehensive. Selection of technologies also depended on technological maturity, interest and investment at the research, development, and demonstration stages, data availability, and applicability for specific grid and end user services. The specific technologies that we focus on in this study include pumped hydro storage, flywheels, compressed air energy storage, lead acid batteries, lithium-ion batteries, sodium sulfur batteries, vanadium redox flow batteries, power-to-gas via hydrogen electrolysis, chilled water, ice storage, water heater energy storage, super capacitors, and superconducting magnetic energy storage.

Assumptions regarding cost and performance are summarized in this section and drawn from several sources. In addition to this report, we have also provided a companion spreadsheet with cost and performance assumptions embedded in our cost analysis. Because lithium-ion batteries represent a significant share of the battery storage market and given their rapid price declines, we have included both current and projected 2030 prices of this technology. For perspective, among batteries and electromechanical storage systems (excluding pumped hydro), lithium-ion batteries represented 98.8% market share in the fourth quarter of 2017 and have led the market for the past 13 quarters (GTM, 2017).

In the summary below, we have grouped storage technologies into the following categories: electromechanical, electrochemical, chemical, thermal, and electrical.

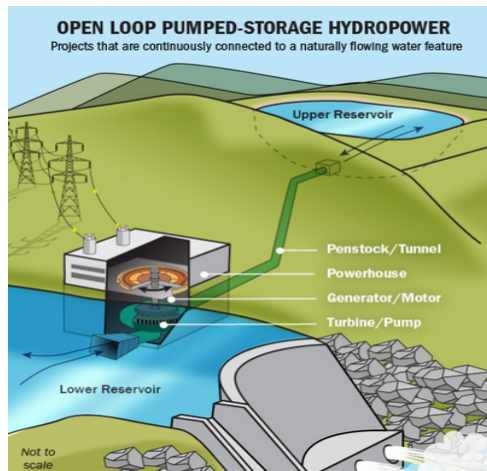
### 4.1 Electromechanical Energy Storage

***Pumped Storage Hydro.*** Pumped storage hydro (PSH) involves pumping large amounts of water to a reservoir at a higher elevation than the source, creating potential energy, then releasing it as needed, using the force of gravity to create kinetic energy that spins a water turbine. A schematic for a system with a continuous water flow is shown in the figure. PSH is a mature technology and represents the largest share of installed U.S. storage capacity: approximately 95% of energy storage capacity is pumped hydro (DOE, 2013) with a capacity of 21.6 GW (NHA, 2018), representing more than 2% of the total U.S. generation capacity (EIA, 2016). Hydroelectric resources can be dispatched within minutes, making them capable of performing necessary utility-scale grid services. Pumped storage projects have long lifetimes, relatively high roundtrip efficiencies, and use a mature, reliable technology. Investment costs can be competitive but are highly dependent on the availability of adequate reservoirs. A main challenge for the development of new PSH is suitable and available siting. In the 2018 Annual Energy Outlook (EIA, 2018), hydropower stays relatively flat



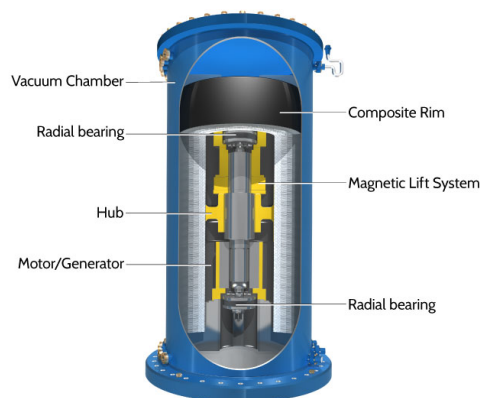
through 2050 due to unfavorable economics and low growth in electricity demand; however, this does not limit the growth of pumped hydro storage, which according to the DOE and NHA has the potential to increase in installed capacity by 16-19 GW (NHA, 2018).

Data to parameterize pumped hydro were drawn from two studies. Zakeri and Syri (2015) disaggregate numerous energy storage technologies, including PSH, and compare installed and operational costs. Average discharge time, variable operations and maintenance costs (VOM), and roundtrip efficiency were taken from this source. Another study was conducted by the Australian National University to assess the cost and stability of high renewable penetration in the Australian National Electricity Market (Stocks, 2017). Technical lifetime, fixed operations and maintenance costs (FOM), and installed power and energy costs were taken from this source.



Schematic representation of pumped hydro. Source: US DOE, 2018.

**Flywheels.** Flywheel technology involves spinning a mass at very high speeds, creating rotational energy from the angular momentum of the object. A radial view of a flywheel deployed for a storage project in Alaska is shown to the right (DOE Global Energy Storage Database, 2018). Flywheels can convert this kinetic energy into electrical power at 93-95% efficiency (Amiryar, 2017). Flywheel systems have long lifetimes and high cycle counts. Small-scale flywheels are ubiquitous, present in virtually all vehicles relying on an internal combustion process. Because grid scale flywheels do not store large amounts of energy, applications have been limited to short term services such as frequency regulation and spinning reserves. The technology is mature but has modest grid-scale deployment to date; 42 MW were deployed across the U.S. in 2016 (U.S. EIA, 2016).



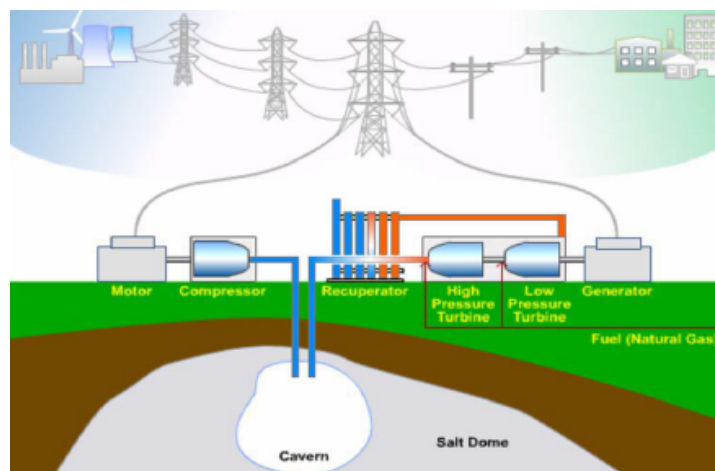
Internal view of a Beacon flywheel energy storage system (FESS) deployed in Alaska in 2015. Source: U.S. DOE Global Energy Storage Database

Data to parameterize flywheels were drawn from Zakeri and Syri (2015) and an International Renewable Energy Association (IRENA) study assessing the current and future costs and market trends of various energy storage technologies. Cost information and standard system discharge duration were taken from Zakeri and Syri (2015), while lifetime and roundtrip efficiency were from IRENA (2018).

**Compressed Air Energy Storage (CAES).** CAES systems use off-peak electricity to run a compressor that pressurizes air, which is stored either in an underground cavern or above ground

engineered tank (DOE, 2013). The more pressurized the gas is, the higher its enthalpy and subsequent power output. When electricity production is needed, the compressed air is heated via natural gas combustion to further increase its enthalpy and prevent the turboexpander blades from freezing during the adiabatic expansion process. Advanced Adiabatic CAES systems collect the heat rejected during the compression cycle and use it to heat the compressed gas during expansion (Li, 2013). While adiabatic CAES eliminates the need for natural gas, it increases cost and complexity, and remains in the research and development phase. Underground storage reservoirs

are most common and potentially cost-effective, capable of providing several hundred MW of power for several hours (DeCarolis and Keith, 2006). Underground reservoirs to store the pressurized air include solution-mined salt caverns, hard rock caverns, depleted gas reservoirs, aquifers, and abandoned mines (DeCarolis and Keith, 2006). A schematic for an underground CAES system with salt dome storage is shown (DOE, 2013).



Schematic of a compressed air energy storage (CAES) system. Source: U.S. DOE Electricity Storage Handbook.

Similar to pumped storage hydro, this technology is very site-specific. Engineered tanks to store the compressed air are prohibitively expensive in most applications, so CAES tends to be limited to areas with suitable geology, but well-designed plants can be cost-competitive (Succar and Williams, 2008). Geology suitable for CAES in North Carolina appears to be limited, but more detailed investigation would be required (Succar and Williams, 2008; Aghahosseini and Breyer, 2018). The turbomachinery components of a CAES system represent mature technology. A 110 MW CAES facility with a 26-hour duration in McIntosh, Alabama has been operational since 1991. Data to parameterize CAES systems were drawn from Zakeri and Syri (2015), and storage reservoir costs were taken from Greenblatt et al. (2007). In addition, since natural gas adds energy content to the compressed air, we assume an electricity output to input ratio of 1.5 (Greenblatt et al., 2007). When used in the bulk energy time shifting analysis (Section 6.5), we assume a natural gas price consistent with the projected 2030 price.

## 4.2 Electrochemical Storage

**Lead Acid.** Lead acid batteries were the first rechargeable battery type. They are low cost, have a relatively high power-to-weight ratio, and have wide versatility in services provided, including vehicles (ALABC, 2013), off-grid power systems, uninterruptable power supplies, and power electronics. The low energy density (energy-to-weight ratio and energy-to-volume ratio) due to the battery chemistry is one of the main reasons that lithium ion batteries are successfully replacing lead acid battery use. While grid-connected lead acid battery systems exist, lithium ion systems dominate the market share (GTM, 2018). Regardless, lead acid batteries are the most mature battery

technology and have continued to see deployments worldwide this decade, including a lead acid carbon battery in Alaska and advanced lead acid technology projects in Japan (DOE, 2013).

Data to parameterize lead acid batteries are drawn from Zakeri and Syri (2015) and IRENA (2018) studies as well as Schmidt et al. (2017), a study on the projected future costs of electrical energy storage systems through 2030. Standard discharge time and FOM were taken from Zakeri & Syri (2015), energy cost in \$/kWh from Schmidt et al. (2017), and round-trip efficiency from IRENA (2018). For all electrochemical storage systems, VOM was assumed to be negligible, with all operational costs represented by FOM.

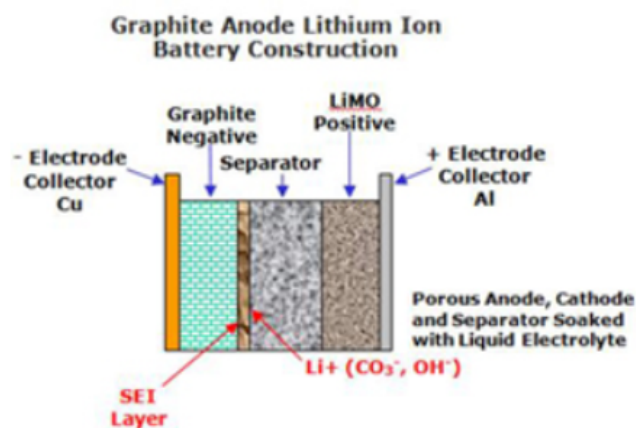
**Lithium Ion.** Lithium ion (Li-ion) batteries are a class of electrochemical storage systems that utilize lithium chemistry in various forms. Li-ion has been dominating market deployment of batteries on the electricity grid in recent years. In 2016, 100% of grid-scale battery projects used lithium chemistry, and lithium ion batteries contributed to 98.8% of market share in Q4 2017, which saw 62 MW of new deployments (100 MWh of energy storage) in the U.S. (GTM, 2018). Though batteries in general are more flexible and can perform a wide variety of services given their fast response time and modularity, the rapidly falling costs of Li-ion batteries have led to widespread grid scale adoption and adoption for electric vehicles. Price decreases have been driven by advancements in battery design, efficiency gains in manufacturing, and increased experience deploying and operating modular systems, which has reduced engineering, procurement, and construction costs (Gupta, 2018). Furthermore, several companies, including Tesla, Panasonic, and Samsung have achieved economies of scale developing Li-ion batteries for power electronic applications, EV batteries, and pairing storage with solar photovoltaic systems (Zelenko, 2018). Li-ion batteries also have a high energy density and fast charge rate relative to lead acid batteries, the battery chemistry they are most frequently replacing. However, because the technology has such a high power density, concerns exist regarding overcharging and risk of fires or explosions in power electronics (Cleave, 2017).

Lithium battery chemistry differs depending on the application, and different breakthroughs at different times resulted in adopting lithium technology for power electronics earlier than for grid-scale applications. The most common lithium battery chemistry used for vehicles and grid scale applications is lithium nickel manganese cobalt oxide (NMC), which has comparatively low energy density but are safer than other Li-ion chemistries and have higher cycle lives. Because of adoption by LG Chem, Samsung, Panasonic, and Kokam, NMC cathodes have steadily decreased in price. (ResearchInterfaces, 2018)

The image shows a typical lithium metal oxide

(LiMO) battery with a graphite anode, a common chemistry in grid scale projects.

Li-ion battery costs have decreased so rapidly throughout this decade that even sources from earlier in 2018 were considered outdated. Data to parameterize Li-ion batteries are drawn from the Lazard Levelized Cost of Storage Analysis published in November 2018. As described in Section 4.6, data



Lithium Ion Battery cross section with metal oxide cathode and graphite anode Source: ESA 2018

from NYSERDA (2018) was also used to scale costs to account for different battery durations as well as projected costs in 2030. Li-ion projects considered were utility scale batteries with durations of 0.5, 1, 2, and 4 hours, commercial scale batteries with 2 and 4 hour durations, and residential scale batteries with 4 hour duration. Details on the cost calculations related to Li-ion batteries are presented below in Section 4.6.

**Sodium Sulfur.** Sodium sulfur (NaS) batteries involve molten sodium and elemental sulfur, both cheap and abundant resources, which undergo a reaction to form sodium polysulfide. The reaction occurs at over 300°C (ESA, 2018), which leads to higher operational costs for this technology (Lazard, 2017) and challenges with variable operation (ESA, 2018). NaS batteries have high energy capacity, energy density, lifetime, and duration; thus, they have been used for mid-sized systems that require several hours of capacity, such as variable generation bulk energy time shifting (Hill, 2013; DOE, 2013). NaS batteries cannot replace Li-ion for EVs due to safety concerns with liquid sodium metal and high operating temperatures, nor can they be used for quick-response grid reliability services such as frequency regulation or spinning reserves. No large scale NaS battery deployments have occurred in the U.S. since 2014 (GTM, 2018). Prior to that time, however, 9 MW were deployed in the U.S. primarily for peak shaving, and large-scale deployments are in operation in Japan (ESA, 2014; NGK, 2018). Data to parameterize sodium sulfur batteries are drawn from Zakeri and Syri (2015) and IRENA (2017). Battery lifetime is from IRENA while cost information is from Zakeri and Syri (2015).

**Flow Batteries.** Flow batteries contain two electrolytic solutions in separate tanks, and electricity comes solely from current generation due to electron flow when connected to a load. Vanadium redox flow batteries (VRB) and zinc bromide (ZBr) are the most common flow battery chemistries; VRBs in particular were considered in this study. Vanadium can exist in four different oxidation states, allowing more electrochemical reduction and oxidation to occur in a smaller space (Weber, 2011). This gives the batteries a higher power and energy density than other flow chemistries of comparable cost. Flow batteries can be scaled up for power or for energy and have room temperature operation (Weber, 2011). These favorable characteristics make flow batteries a potentially attractive alternative; however, the current installed costs have inhibited widespread adoption (EIA, 2016). Only a few large-scale projects have been completed since 2013 (GTM, 2018). Data to parameterize flow batteries were drawn from Zakeri and Syri (2015), though other references were used for validation, including Schmidt (2017).

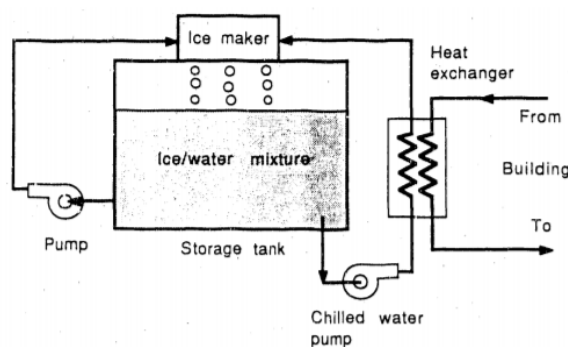
### 4.3 Thermal Energy Storage

**Water Heaters.** By heating the water in a residential or commercial electric water tank to store thermal energy, water heaters can be controlled in real-time to shave peak demand through load shifting. Most water heaters have the necessary insulation and holding capacity to avoid heating water during periods of peak demand on the power system, while maintaining a suitable water temperature. Electric water heaters are widely present in the U.S., with over 54.6 million electric water heaters installed (EIA, 2017).

Besides peak demand deferral, water heaters can also help integrate renewables onto the grid by alleviating curtailment. Fifty-five million electric water heaters have been installed in the U.S with an average peak electric consumption of 5 kW, suggesting great potential for load shifting (Lazar, 2016). The Rocky Mountain Institute estimates the U.S. market to be \$3.6 billion, which is split up amongst several parties, including utilities, GIWH manufacturers, installers, solar companies, aggregators, and customers (McCall, 2016). Furthermore, the GIWH manufacturers have no current incentives to install water heaters that can respond to grid needs, as the potential savings can go to the utility, the customer as bill savings, or an aggregator (Tribash, 2017).

Data to parameterize water heaters were drawn from a Brattle group study on the benefits on fast response water heaters (Hledik, 2016) and by utilizing the DOE Energy Cost Calculator for water heaters (DOE, 2018). According to the Brattle group study, the vast majority of end-user service benefits for water heaters are achieved with systems capable of performing fast response, so the pertinent cost data for these systems was used (Hledik, 2016). Round trip efficiency was taken from Alliant Gas's comparison of propane to electric water heating, and FOM and lifetime were taken or calculated from the DOE Energy Cost Calculator.

**Ice Storage.** Ice storage technology involves freezing water during off-peak hours and supplying cool air to reduce air conditioning load. Water has a high heat of fusion and specific heat, so it can provide this cooled air without taking up significant space. Since water is very cheap, the cost of these systems is competitive with other storage solutions (Calmac, 2001). Over 80 projects exist around the state, totaling 99 MWh of storage. A common setup, the dynamic ice storage system, is shown (ORNL, 1988).



Schematic for dynamic energy storage system Source: Lawrence Berkeley National Lab, 1988

Cost data for ice storage was obtained from a personal correspondence with Ingersoll-Rand in November 2018.

**Chilled Water Storage.** Chilled water energy storage systems provide a similar service to ice storage. The structure of the system is a steel or concrete tank with water stored at 40 to 42 °F, kept cold with traditional chillers. Water chilled during off-peak hours can provide cool air during peak times. While the systems are simpler, they are less effective than ice storage because they rely on the sensible heat of water rather than latent heat. Thus, the system footprint is much larger and usually cannot be included in the building itself. Chilled water systems exist all around the U.S, including Raleigh, NC, primarily for reducing air conditioning energy costs (DOE, 2018).

#### 4.4 Chemical Storage

**Hydrogen.** Hydrogen (H<sub>2</sub>) electrolysis involves splitting water molecules into H<sub>2</sub> and O<sub>2</sub> gas. The H<sub>2</sub> can be stored and later burned to produce steam (H<sub>2</sub>O), which generates electricity by running a turbine. An electrical current and a metal catalyst are required to perform electrolysis, with the

platinum or palladium metal catalyst typically being the costliest component of the process (Schmidt et al, 2017). However, H<sub>2</sub> has a very large specific energy – over triple that of gasoline – and when compressed to over 5,000 psi, as is necessary to create hydrogen batteries and fuel cells for vehicles, can provide an energy output similar or greater than a traditional internal combustion engine at twice the efficiency (Huang, 2015; GreenEcon, 2008). Safety is one of the primary concerns of using H<sub>2</sub>, alongside a lack of infrastructure for vehicles in areas other than California. Storage projects typically reporting a very high levelized cost (~\$10/kWh) (Satyapal, 2014).

Data to parameterize H<sub>2</sub> electrolysis were taken from several different sources. System capital and operating costs were taken from Bertuccioli (2014), ENEA (2016), and Felix (2016); efficiency information was taken from ENEA (2016) and Ursua (2012); and power consumption information was taken from ENEA (2016) and NIST (2018).

**Power to Gas.** In this report, we consider H<sub>2</sub> and synthetic methane production as part of the power-to-gas (PtG) process. PtG is any technology or process that converts electrical power into gaseous fuel, typically hydrogen or methane. In methanation, electrolyzed hydrogen is combined with carbon dioxide – sequestered or otherwise – in the Sabatier reaction to create methane (CH<sub>4</sub>). Pressurized methane can be used as natural gas for heating, electricity, or directly injected into natural gas pipeline infrastructure. PtG plants are beginning to become cost-competitive in Germany for their carbon neutrality and ease of use where NG infrastructure exists (Götz, 2017). Once the water has been electrolyzed, the H<sub>2</sub> is pressurized and can either be fed directly into the existing natural pipeline infrastructure up to 10% by volume, or it can be used in a process to produce synthetic natural gas. In either case, the H<sub>2</sub> or synthetic methane can be used to power gas turbines. While additional production routes exist, such as H<sub>2</sub> storage and distribution for fuel cell vehicles or methanol production for internal combustion engine vehicles, such pathways were deemed outside the scope of this study. A few PtG plants exist in the U.S. and pilot plants exist in California (NREL, 2017).

In this analysis, we optimistically assume that electrolysis runs on free electricity produced with curtailed solar. The H<sub>2</sub> produced can either be fed into the existing natural gas pipeline infrastructure up to a 10% by volume, or used to produce synthetic methane via the Sabatier reaction. Data to parameterize PtG comes from all the above-referenced documents for H<sub>2</sub> electrolysis, with additional information taken from Götz (2017), Bernd (2017), and ENEA (2016) for system capital and operating costs, the cost of CO<sub>2</sub>, and system efficiency, respectively. The estimated revenue requirements account for equipment and materials required to produce H<sub>2</sub> and methane, but we do not account for the generation equipment required to convert these fuels back into electricity. The revenue requirements translate into a levelized cost of 13 \$/GJ for H<sub>2</sub>, and 21 \$/GJ for synthetic methane. For reference, the current US average natural gas price in 2017 was 3.5 \$/GJ (EIA, 2018).

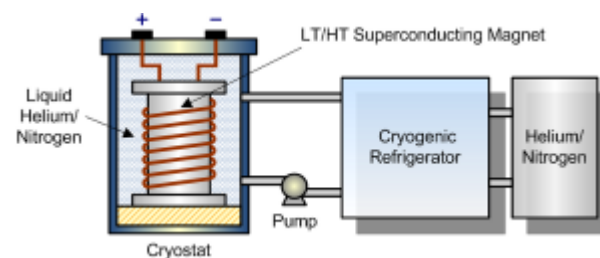
## 4.5 Electrical Storage

**Super Capacitors.** Super capacitors store electrical energy at electrode-electrolyte interfaces. Devices consist of two metal plates coated with porous activated carbon to maximize energy density, though relative to other energy storage technologies it is still pretty low (IEA, 2009). The technology has a long theoretical lifespan and an impressively slow degradation rate. They cannot be used as a continuous energy source, but can provide a short burst of energy in milliseconds as a means of

jump-starting other technologies with larger energy capacities (IEA, 2009). For this reason, demo-scale projects and research focus on use in microgrids as a way to start backup generators or electronically lock doors (Chmiola, 2009). Another use is regenerative braking for public transportation (IEA, 2009). Currently the technology is very expensive; the best material used for the electrodes is graphene, another carbon-based material that is light, thin, 200x stronger than steel, and, for the moment, very costly. However, graphene-based super capacitors show promise, with comparable energy density in Wh/kg to batteries but with a much faster discharge rate (Liu, 2010).

Data to parameterize super capacitors is drawn from Zakeri and Syri (2015), IEA (2009), and Chmiola (2010). System cost information was taken from Zakeri and Syri (2015), roundtrip efficiency and lifetime from IEA (2009), and typical discharge duration from Liu (2010).

**Superconducting Magnetic Energy Storage (SMES).** SMES systems store energy in a magnetic field created by a current in a superconducting coil cryogenically cooled to a temperature below its superconducting critical temperature (Biswas, 2009). The storage of electricity itself incurs near-zero losses over time. Inverting from DC-AC and back again is the only form of energy loss, leading to round trip efficiencies comparable to flywheels, typically higher than 95% (Biswas, 2009). The power is available almost instantly when needed and since the systems can be extremely power dense in W/kg, output power for pilot projects can be available within milliseconds of being called on to discharge (Chmiola, 2009). The high cost of refrigeration and the high cost of the superconducting material limit the technology to short term uses. Also, while power density can be 10-100x higher than current battery technology, depending on the chemistry, energy density is much lower. A typical SMES system is shown. Data to parameterize SMES were taken from Zakeri and Syri (2015), IEA (2009), and Connolly (2009).



Schematic of a superconducting magnetic energy storage system Source: Energy Storage Sense

#### 4.6 Method for Calculating Storage Costs

Key cost and performance characteristics associated with storage technologies described above are provided in Tables 4.1 and 4.2. Given the intense stakeholder interest in lithium-ion batteries, we have provided those costs separately in Table 4.2. In all cases, 'system cost' represents the total installed cost, which includes the equipment cost, balance of system cost, engineering procurement cost, and any other cost required to make the storage technology ready for deployment. For battery-based technologies, the equipment cost includes both the battery and inverter costs.

**Table 4.1.** Cost analysis summary of energy storage technologies, excluding Li-ion batteries

Technology	System Cost <sup>a</sup> \$/kWh	Duration (hr.)	Lifetime (yr)	FOM <sup>b</sup> (\$/kWyr)	VOM <sup>c</sup> (\$/kWyr)	R.T.E <sup>d</sup> (%)	Source(s)
Pumped Hydro	170	8	50	10	0.00029	75	Zakeri & Syri (2015), Stocks (2017)
Flywheel	4541	0.5	20	7	0.0027	95	IRENA (2016), Zakeri & Syri (2015)
CAES	106	8	30	5.2	0.0042	95	Zakeri & Syri (2015)
NaS	474	6.6	17	4.8	0	85	Zakeri & Syri (2015)
Lead Acid	658	2	10	42	0	82	Lazard (2018)
Flow	483	4	20	109	0	75	Lazard (2018)
Ice	310	6	30	12	0	97	Ingersoll Rand, 2018
Chilled Water	130	6	25	180	0	70	Fang (2004), Yan (2017), Ingersoll Rand (2001)
Water Heaters	100	4	12	15.8	0	92	DOE (2018a), Hledik et al, 2016, Alliant Gas (2018)
SMES	8453	1	15	0	0	90	IEA (2009), Connolly (2009), Zakeri & Syri (2015)
Super-capacitor	1332	1	15	0	0	90	IEA (2009), Chmiola (2009), Zakeri & Syri (2015)
H <sub>2</sub> <sup>e</sup>	1852		20	196	0	70	Bertuccioli (2014), ENEA (2016), Zakeri & Syri (2015)
Power-to-Gas <sup>f</sup>	644		20	187	0	79	Gotz (2017), Jentsch (2014), Bernd & Decarolis (2017), ENEA (2016)

<sup>a</sup> Includes total installed cost, which includes the equipment cost, balance of system cost, engineering procurement cost, and any other cost required to make the storage technology ready for deployment

<sup>b</sup> Fixed Operations and Maintenance

<sup>c</sup> Variable Operations and Maintenance

<sup>d</sup> Roundtrip Efficiency

<sup>e</sup> H<sub>2</sub> represents hydrogen production through electrolysis, which can then injected into the existing natural gas network; the process can be considered continuous, and thus the duration is not specified; system cost for H<sub>2</sub> and power-to-gas is in \$.kW rather than \$/kWh

<sup>f</sup> Power-to-Gas relies on H<sub>2</sub> produced through electrolysis, which is described in the row above

The costs provided above are used to calculate the revenue requirement. In this study, we use the revenue requirement to represent the annual fixed cost associated with a given storage technology. The revenue requirement is calculated by amortizing the system cost at a 10% interest rate over the technology lifetime and adding the fixed operations and maintenance (FOM) cost. While the revenue requirement may suggest a utility focus, in this study we use it consistently across all service categories, including behind-the-meter, to represent the fixed costs incurred through storage



ownership. Using pumped hydro as an example, the revenue requirement is calculated as follows using the values in Table 4.1:

$$\text{Revenue Requirement} = 170 \frac{\$}{kWh} \cdot 8hrs \cdot \frac{0.1}{1-(1+0.1)^{-50}} + 10 \frac{\$}{kWyr} = 147 \$/kWyr \quad (4.1)$$

The revenue requirement estimates are then used within each of the service-specific analyses. Note that the roundtrip efficiency and variable operations and maintenance costs are used within each service-specific analysis and affect the calculation of benefits.

Costs and performance characteristics for Li-ion batteries are broken out separately in Table 4.2. Costs are based on Lazard (2018), which was released in November 2018. The utility scale batteries are assumed to have a 20-year lifetime, and include both extended warranty and augmentation costs. Augmentation represents the annual expense required to replace dead cells and maintain the battery beyond the assumed fixed operations and maintenance cost. The extended warranty covers the battery beyond the initial 2-year manufacturer's warranty. In Table 4.2, both the extended warranty and augmentation costs are added together and treated as an annual recurring expense. We omit extended warranty and augmentation costs in the scenarios examining frequency regulation with utility-scale batteries, since the rapid response required in that application often entails significant degradation. We instead assume a 10-year battery life with no warranty or augmentation costs when examining frequency regulation.

Likewise, we assume a 10-year battery lifetime for both the commercial and residential scale batteries. We make the simplifying assumption that commercial and residential purchasers of batteries will forgo an extended warranty and augmentation, given the relatively low duty cycle of the associated applications. Including warranty and augmentation costs with an extended 20-year lifetime increases the revenue requirement for both commercial and residential batteries on the order of 10%.

Cost estimates for the 4-hour utility-scale battery, 2- and 4-hour commercial scale battery, and 4-hour residential scale battery are drawn directly from Lazard (2018). We use the midpoint of the cost ranges on pp. 28-29 of Lazard (2018). As an example, consider the 4-hour utility scale battery. The initial DC capital cost range is 232 – 398 \$/kWh, initial AC capital cost range is 49 – 61 \$/kWh, and EPC is 40 \$/kWh. Taking the midpoint of both the DC and AC cost ranges, the system cost is:

$$\text{system cost} = 315 \frac{\$}{kWh} (DC) + 55 \frac{\$}{kW} (AC) * \frac{1}{4 hrs} + 40 \frac{\$}{kWh} (EPC) = 369 \frac{\$}{kWh} \quad (4.2)$$

which is the value provided in Table 4.1. The revenue requirement calculation then follows the same general form as shown in Equation 4.1.

To adjust Li-ion battery system costs based on Lazard (2018) for different durations, we use scaling factors derived from NYSERDA (2018), which considers a broader range of battery durations. For example, in NYSERDA (2018), the system cost (\$/kWh) for a 2-hour utility scale battery is 35% higher than the 4-hour battery, and this scaling factor was used to estimate the 2-hour battery system

cost in our analysis. The warranty and augmentation costs were also scaled with the system cost. Annual operations & maintenance costs (in \$/kWh-yr) were simply scaled by battery duration.

Consistent with both NYSERDA (2018) and McKinsey (2018), we assume that the 4-hour utility scale Li-ion battery will reach a system cost of 200 \$/kWh in 2030. The reduction from 369 to 200 \$/kWh represents a 46% decline in the system cost, and this percentage reduction in system cost is applied uniformly across all Li-ion batteries to represent cost in 2030. There is room for debate whether these cost targets will be met sooner than 2030, or perhaps not at all. The break-even cost estimates for each modeled scenario, provided in the accompanying spreadsheet and Section 7, indicate the cost at which a storage technology becomes cost-effective, regardless of when that cost is reached.

**Table 4.2.** Cost analysis summary of Li-ion batteries

Scale	Year	Duration (hr)	System Cost (\$/kWh)	Lifetime <sup>a</sup> (yrs)	FOM (\$/kW-yr)	Warranty + Augmentation <sup>b</sup> (\$/kW-yr)	R.T.E <sup>c</sup> (%)
Utility	2019	0.5	1162	20	2	31	85
	2030	0.5	532	20	2	14	85
Utility	2019	1	940	20	4	50	85
	2030	1	431	20	4	23	85
Utility	2019	2	498	20	8	53	85
	2030	2	228	20	8	24	85
Utility	2019	4	369	20	15	78	85
	2030	4	200	20	15	36	85
Commercial	2019	2	561	10	42	0	85
	2030	2	257	10	42	0	85
Commercial	2019	4	551	10	83	0	85
	2030	4	252	10	83	0	85
Residential	2019	4	748	10	71	0	85
	2030	4	342	10	71	0	85

<sup>a</sup> The scenario-specific lifetimes associated with using Li-ion batteries for frequency regulation are estimated in Section 6.6 of the report.

<sup>b</sup> Warranty and augmentation costs are assumed for utility scale batteries in order to extend their lifetime to 20 years. We assume that warranty and augmentation scale with investment cost; as cells costs decline, we expect these costs to decline with it.

<sup>c</sup> Roundtrip efficiency drawn from Zakeri and Syri (2015), consistent with other sources. Lazard (2018) estimate is slightly higher, but was released after the analysis was completed.

## References

- Akbari, H. (1988) Thermal energy storage for cooling of commercial buildings. Lawrence Berkeley National Laboratory
- ALABC (2013) Do Hybrid Electric Vehicles Use Lead-Acid Batteries? Yes! Here's why Accessed from <http://www.alabc.org/publications/do-hybrid-electric-vehicles-use-lead-acid-batteries-yes-here2019s-why>
- Aghahosseini, A., Breyer, C. (2018). Assessment of geological resource potential for compressed air energy storage in global electricity supply. *Energy Conversion and Management*, 169: 161-173.
- Alliant Gas (2018) How efficient is propane over electric? Accessed from <http://www.alliantgas.com/why-propane/efficiency-comparison-charts>
- Amiryar, M. & Pullen, K. A Review of Flywheel Energy Storage System Technologies and Their Applications, *Applied Sciences*, 2017, Volume 7, 286
- Anderson, M (2015) Economic and Environmental Analysis of Cool Thermal Energy Storage as an Alternative to Batteries for the Integration of Intermittent Renewable Energy Sources. Virginia Polytechnic Institute and State University. Master's Thesis
- Barbour, E. (2013) Superconducting Magnetic Energy Storage (SMES). *Energy Storage Sense* <http://energystoragesense.com/superconducting-magnetic-energy-storage-smes/> accessed October 25, 2018
- Bertuccioli, L., Chan, A., Hart, D., Lehner, F., Madden, B., Standen, E. (2014) Study on development of water electrolysis in the EU<sup>6</sup>, Final Report, program: Fuel cells and Hydrogen - Joint undertaking
- Biswas, M. et al. (2013) Towards Implementation of Smart Grid: An Updated Review on Electrical Energy Storage Systems, *Smart Grid and Renewable Energy* 4(1):122-132, 2013 DOI: 10.4236/sgre.2013.41015
- Chmiola, J. et al. (2009) Low-cost Supercapacitors for Household Electrical Energy Storage and Harvesting, *ECS Transactions*, 16 (24) 13-21
- Cleave, K. (2017) Lithium Batteries the Culprits in Samsung Note 7 Debacle, Company Finds, CBS
- Connolly, D. & Leahy, M. (2009) A Review of Energy Storage Technologies: For the integration of fluctuating renewable energy, University of Limerick
- DeCarolis, J. & Keith, D. (2006) The Economics of Large-scale Wind Power in a Carbon Constrained World, *Energy Policy* 34 395–4106
- Department of Energy (2018) Energy Cost Calculator for Electric and Gas Water Heaters
- Department of Energy Electricity Storage Handbook 2013
- Department of Energy (2018) Pumped-Storage Hydropower. <https://www.energy.gov/eere/water/pumped-storage-hydropower-date>. Accessed October 14, 2018.

- Department of Energy (2018) Global Energy Storage Database <https://www.energystorageexchange.org/projects/1750>. Accessed August 14, 2018
- Energy Information Administration (2016) EIA 860 Data for 2016.
- Energy Information Administration (2018) Battery Storage Market Trends
- Energy Information Administration (2018). Natural Gas Prices. [https://www.eia.gov/dnav/ng/ng\\_pri\\_sum\\_dcu\\_nus\\_a.htm](https://www.eia.gov/dnav/ng/ng_pri_sum_dcu_nus_a.htm). Accessed November 23, 2018.
- Energy Information Administration Electric Power Annual 2016, Table 4-3
- ENEA Consulting (2016) The Potential of Power-To-Gas. 33(0), pg. 51
- Energy Storage Sense (2013) Energy Storage Technologies: Superconducting Magnetic Energy Storage (SMES) <http://energystoragesense.com/superconducting-magnetic-energy-storage-smes/> accessed October 25, 2018
- Energy Storage Association (2018) ESA: Lithium-Ion Batteries <http://energystorage.org/energy-storage/technologies/lithium-ion-li-ion-batteries> accessed October 24, 2018
- Energy Storage Association (2018) ESA: Sodium Sulfur (NaS) Batteries
- Fang, G. (2004) Economic Analysis of Cool Storage Air-Conditioning Systems, International Journal on Architectural Science, Volume 5, Number 2, p.47-51
- Felix, O., Wiede, T., Meinecke, M., König, R. (2016): “Netzentwicklungsplan 2025, 2. Entwurf
- Frankel, D. Kane, S. & Tryggestad, C. (2018) The New Rules of Competition in Energy Storage, McKinsey & Company <https://www.mckinsey.com/industries/electric-power-and-natural-gas/our-insights/the-new-rules-of-competition-in-energy-storage> accessed
- Götz, M. et al (2016) Renewable Power-to-Gas: A technological and economic review“, Renewable Energy 85, p. 1371-1390
- Greenblatt, J. B., Succar, S., Denkenberger, D. C., Williams, R. H., Socolow, R. H. (2007). Baseload wind energy: modeling the competition between gas turbines and compressed air energy storage for supplemental generation. Energy Policy, 35(3): 1474-1492.
- GreenEcon (2008). Ethanol Offers Short-Term Solutions, but Corn-Based Ethanol is Not the Answer
- Green Tech Media, U.S Energy Storage Monitor: Q4 2017 Year in Review and Q1 2018 Full Report
- Gupta, M. (2018) U.S. Front-of-the-Meter Energy Storage System Prices 2018-2022 GreenTech Media (GTM) Research
- Hill, C. (2013) Grid-Scale Battery Energy Storage Systems, University of Texas- Austin Master’s Thesis.
- Hledik, R. Chang, J., & Leuken, R. (2016) The Hidden Battery: Opportunities in Electric Water Heating. The Brattle Group
- Huang, Pei-Hsing & Kuo, Jenn-Kun & Huang, Chun-Yen. (2015). A new application of the UltraBattery to hybrid fuel cell vehicles. International Journal of Energy Research. 40.

- IEA (2009). Prospects for Large-Scale Energy Storage in Decarbonized Power Grids
- Ingersoll-Rand. (2001) Economic Analysis of Typical Partial and Full Storage Installations, Calmac Manufacturing Corporation
- IRENA (2018), Renewable Power Generation Costs in 2017, International Renewable Energy Agency, Abu Dhabi.
- Jentsch, M. et al (2014), Optimal Use of Power-to-Gas Energy Storage Systems in an 85% Renewable Energy Scenario, *Energy Procedia*, 46, pg. 254-261
- Lawrence Berkeley National Lab (1988), Thermal energy storage for cooling of commercial buildings <https://www.osti.gov/servlets/purl/6541101> accessed October 25, 2018
- Lazar, J. (2016) Teaching the ‘Duck’ to Fly: Second Edition. Montpelier, VT: The Regulatory Assistance Project
- Lazard (2017, 2018) Levelized Cost of Storage Analysis: Version 4.0.
- Li, B. & DeCarolis, J. (2013) The Economic Performance of the Ocean Compressed Air Energy Storage
- Liu, C. et al. (2010) Graphene-Based Supercapacitor with an Ultrahigh Energy Density, *Nano Lett.* 10, 12, 4863-4868
- Massachusetts Department of Energy Resources (2016) State of Charge: Massachusetts Energy Storage Initiative. Department of Energy Resources
- McCall, M. (2016) How grid-interactive water heaters are joining the battery revolution. Rocky Mountain Institute
- National Hydropower Association (NHA) (2018) Pumped Storage Report
- National Institute of Standards and Technology (NIST) (2018). Isothermal Properties of Hydrogen, NIST Chemistry WebBook, SRD 69
- National Renewable Energy Laboratory (2017). NREL and Southern California Gas Launch First U.S. Power-to-Gas Project
- Newbury, D. et al (2018) Shifting demand and supply over time and space to manage intermittent generation: The economics of electrical storage, *Energy Policy*, 113. pg 711-720.
- NGK Insulators (2018) Sodium Sulfur Battery Case Studies. Accessed [https://www.ngk.co.jp/nas/case\\_studies/](https://www.ngk.co.jp/nas/case_studies/)
- Nomura, S. et al (2010) Technical and Cost Evaluation on SMES for Electric Power Compensation, *IEEE*, Vol 20, 3, 2010
- NYSERDA (2018) New York State Energy Storage Roadmap. <https://www.nyscrda.ny.gov/All%20Programs/Programs/Energy%20Storage/Achieving%20NY%20Energy%20Goals/The%20New%20York%20State%20Energy%20Storage%20Roadmap>.

Satyapal, S. (2017) Hydrogen and Fuel Cells Overview, DOE Fuel Cell Technologies Office, DLA Worldwide Energy Conference

Schmidt, O. et al. (2017) Future cost and performance of water electrolysis: An expert elicitation study, International Journal of Hydrogen Energy, Volume 42(52), pg. 30470-30492

Stocks, M. Blakers, A. & Lu, B. (2017) Pumped Hydro Energy Storage to support a 50-100% renewable electricity grid. Australian National University

Succar, S. & Williams, R. (2008) Compressed Air Energy Storage: Theory, Resources, And Applications For Wind Power, Princeton Environmental Institute

Trabish, H. (2017) Utilities in hot water: Realizing the benefits of grid-integrated water heaters.

U.S. DOE (2013) Grid Energy Storage in 2013

Ursua, A. Gandia, L and Sanchis, P (2012) “Hydrogen Production From Water Electrolysis: Current Status and Future Trends,” Proc. IEEE, vol. 100, no. 2, pp. 410–426

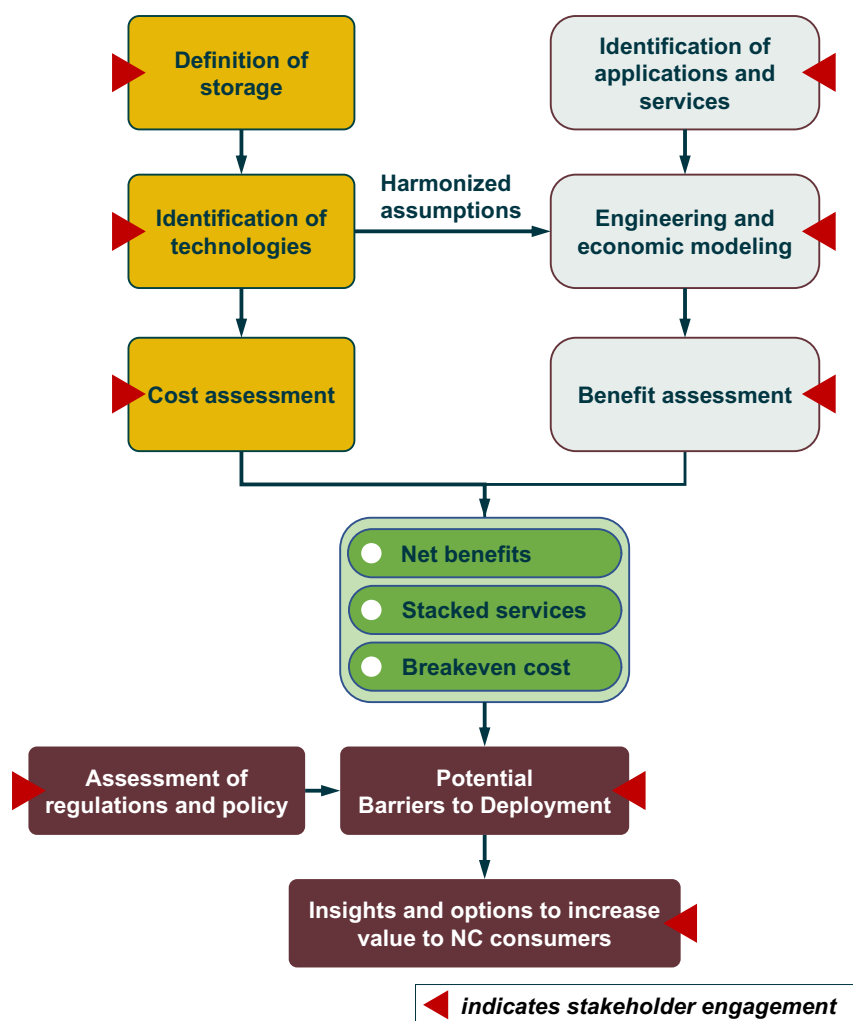
Weber, A. et al. (2011) Redox flow batteries: a review. J. Appl. Electrochem. (41) 11-37

Yan, C., et al (2017). Retrofitting building fire service water tanks as chilled water storage for power demand limiting. Building Services Engineering Research and Technology, 38(1), 47–63.

Zelenko, M. (2018) The US is losing the high-stakes global battery war, The Verge August 13

## 5. Overview of Our Approach

Electricity grid planning and operation is highly complex, and there is no way to address all relevant issues – from capacity expansion planning to frequency regulation – simultaneously in the same modeling exercise. As a result, we have devised a series of model-based analyses to evaluate the value of specific storage technologies fulfilling particular services. These service-specific analyses are presented in Section 6. Our overall approach to the study is outlined in Figure 5.1.



**Figure 5.1.** Work flow diagram explaining our approach to the analysis. On the left, our definition of storage led to the identification of key technologies and a cross-cutting assessment of technology-specific costs. We separately identified a series of grid services and applications where storage can plan a role, and conducted a series of application-specific analyses to assess benefit. Costs and benefits were used to compute net benefits, break-even costs, and identify potential stacked services. Along with the policy assessment, we use the benefit-cost analysis to assess the value of storage to NC consumers.

We utilize our working definition of storage (Section 1) to identify a set of storage technologies for evaluation. A brief assessment of each storage technology is provided in Section 4, and a cost spreadsheet containing key input assumptions has been made publicly accessible on the project website<sup>2</sup>. The result is a set of harmonized cost and performance assumptions for each technology evaluated in the study.

In parallel, we identified and prioritized the relevant set of services and applications that could be fulfilled by storage (Section 3). We then examined the compatibility between services and storage technologies, and identified high priority needs for analysis. Table 5.1 presents the intersection between all storage technologies and services, noting where there is a match, mismatch, and where matches occur, whether we have conducted formal analysis in this study. We apply two criteria when evaluating whether a particular storage technology can meet a particular service: (1) the storage duration associated with a particular technology can be sufficient to meet service's needs, (2) the scale of the storage system is appropriate for the application in question, and (3) the storage technology can ramp quickly enough to meet service needs. We recognize that some of these determinations may not be clear-cut and that the storage landscape is dynamic, with new opportunities emerging over time. For compatible storage technologies and services in Table 5.1, the color is proportional to the revenue requirement in \$/kWyr. Note that the revenue requirement is indicative of costs; however, the benefits associated with a given storage technology fulfilling a particular service can vary widely.

We perform a cross-cutting cost assessment for each technology in Table 5.1, but the assessment of benefits requires specialized analysis for each service category. In order to make the scope of the analysis more tractable, we perform benefit-cost analysis with selected technologies that show the most promise through 2030, identified as such in Table 5.1 with a "\*". Multiple scenarios under each service category allow us to evaluate the value of storage under different assumptions. For example, the end-user service category consists of several scenarios addressing commercial and residential applications of storage under different tariffs.

Because different storage technologies have different lifetimes, we annualize the costs and benefits to enable consistent economic comparisons across technologies and services. Thus, each service-specific analysis produces a series of net benefit estimates in \$/kWyr. A negative net benefit indicates that cost is a barrier to deployment. In all scenarios, we calculate the technology-specific break-even system cost (i.e., capital cost) required to make the application cost-effective.

We also estimate the potential scale of deployment for each service category across the state by developing the following categories: small (<100 MW), medium (100-1000 MW), large (> 1000 MW). The net benefit information informs our estimates of potential deployment through 2030. Section 7 details our analysis of market size.

Apart from the techno-economic analysis, we have developed a detailed review of existing NC storage-related policies. In addition, we have reviewed policies considered in other states, which provides a menu of options to help address barriers to energy storage deployment in North Carolina. Thus our approach allows us to evaluate the value of storage through both bottom-up techno-economic analysis and top-down policy review.

---

<sup>2</sup> Project website: <https://energy.ncsu.edu/storage>



**Table 5.1.** Suitability of energy storage technologies in meeting specific services and applications. Box color is proportional to the calculated revenue requirement; white boxes indicate a mismatch between technology and service. Asterisks indicate technology-service combinations for which the benefit-cost analysis was performed.

		Electrochemical <sup>a</sup>				Mechanical			Thermal			Electrical		Chemical <sup>b</sup>	
		Li-ion	Sodium sulfur	Flow batteries	Lead acid	Flywheels	Pumped hydro	Compressed air	Chilled water	Ice Storage	Water heaters	Supercapacitors	SMES	H <sub>2</sub> Production	Synthetic Methane Production
End-User	Time-of-Use/Energy Management	*							*	*					
	Demand Charge Management	*							*	*					
	<i>Backup Power <sup>c</sup></i>														
	<i>Distributed Energy Management</i>														
	<i>Power Quality Management</i>														
Distri- bution	Voltage Support and Control	*													
	Microgrid/Islanding	*													
	Circuit Upgrade or Capacity Deferral	*													
Trans- mission	Transmission Investment Deferral														
	Transmission Congestion Relief														
	<i>Black Start Capacity</i>														
Generation and Resource Adequacy	Bulk Energy Time Shifting	*		*			*	*							
	Peak Capacity Deferral	*		*			*	*							
	<i>Reserves (Spinning/Non-Spinning)</i>														
	Frequency Regulation	*				*									
	<i>Flexible Ramping</i>														
	<i>Synthetic Inertia</i>														
	Solar Clipping	*													

<sup>a</sup> For consistency, the revenue requirements displayed here associated with Li-ion batteries are 4-hour duration.

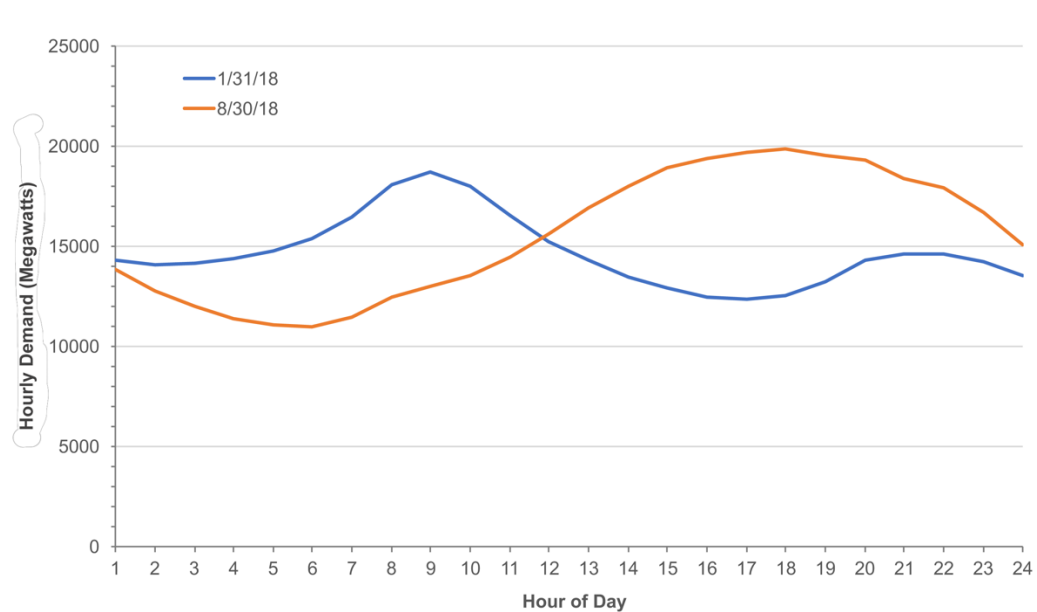
<sup>b</sup> While power-to-gas can encompass many options, here we limit our analysis to the production of hydrogen and synthetic natural gas through electrolysis of water. Longer term consideration beyond 2030 could both stationary fuel cells and fuel cell vehicles that could serve a larger array of services.

<sup>c</sup> The services listed in italics were not explicitly analyzed for reasons discussed in Section 3. Transmission services were evaluated, but we did not analyze the cost-effectiveness of specific storage technologies because we lacked the data to do so.

## 6.1. End-User Services

In this report, *end-user services* refers to behind-the-meter applications of storage that are implemented by end user consumers in the residential, commercial, and industrial sectors. While different end-users are responding to different incentives and tariff structures, their common objective is to save money by reducing their demand for grid electricity at times when rates are high. In this section, we outline a number of scenarios in each customer sector to demonstrate applications where end-users may benefit from energy storage installation.

The key driver for utilities to support customer investments in behind the meter energy storage is reducing peak electric demand. Figure 6.1.1 below shows the 2018 winter and summer peak days for Duke Energy Carolinas, which represents nearly half of the demand for electricity in NC. These peaks are produced by customer heating and cooling loads, and the demand periods vary due to daily and seasonal variations in temperature. Peak hours typically occur in the late afternoon during summer months, in the early morning in winter, and during either period in shoulder months. By promoting demand reductions during winter and summer peak hours, utilities can avoid investments in new peak generation.



**Figure 6.1.1.** Demand curves for summer and winter peak days in Duke Energy Carolinas. Data drawn from the U.S. Energy Information Administration, [http://www.eia.gov/realtime\\_grid](http://www.eia.gov/realtime_grid).

Given the smaller required storage capacities for these applications, we limit the consideration of storage technologies for behind the meter applications to batteries and thermal storage. As shown in Table 6.1.1, there are a number of other proven technologies that end-users have traditionally relied on for demand reduction. Energy storage systems can be controlled to closely align their output with periods of peak demands, so they can be more effective than other technologies at reducing peak demands.

**Table 6.1.1.** Energy Storage Compared to Other End-User Demand Reduction Technology Choices

Characteristic	Energy Storage	Energy Efficiency	Operation & Controls	Peak Shaving Generator	Renewable Generation
Typical Applications	Battery, Flywheel, Thermal	VFDs, Compressors, Chillers	Energy management, load shedding, IoT	Diesel or Natural Gas Generator	Solar PV, thermal, biogas
Annual Capacity Factor	2% - 30%	60-100%	100%	2-3%	16-20%
Effectiveness at Time of Peak Demand	Excellent	Good	Very Good	Excellent	Good
Size Range	3 kW – 2 MW	varies	varies	100 kW – 20 MW	varies
Footprint Required	160 sf	existing	existing	320 sf+	100 sf for 1 kW
Capital Cost, \$/kW <sup>a</sup>	\$ 1,200 – \$ 2,100	varies (e.g., chiller, \$300/T)	varies	\$ 600-700	\$ 2,500 solar \$ 6,000 biogas
Incremental O&M Cost, \$/kW/year	5-10 yr replacement	\$ 0	varies	depends on contract	n/a

<sup>a</sup> Costs shown for energy storage and other demand reducing technologies are approximate and will vary by technology and size. Generator pricing is taken from manufacturer data. Renewable generation costs are current market averages for systems of <500 kW capacity in NC.

To estimate the potential benefits of energy storage in NC, scenarios were analyzed using spreadsheet models to calculate the benefits of specific storage applications and, using the costs and revenue requirements developed in Section 4, determine net benefits. For behind the meter storage applications using batteries with and without solar PV, the System Adviser Module (SAM, 2017) was first used to calculate solar PV generation and energy demand reductions. SAM uses hourly weather data to calculate solar PV performance for a specific location, and has typical load profiles for large industrial, medium commercial, and residential sites, which were used in the scenarios studied. The output from the energy storage unit was then applied to the PV only case as an independently controlled system, capable of reducing the site's demand for a period specified in each scenario.

### 6.1.1 Opportunities in Existing Retail Electric Rates for Energy Storage

In North Carolina, existing retail electric rates and their design provide opportunities for end users to install storage and realize benefits by reducing electricity usage during peak demand periods. Electric utilities in NC are authorized to recover costs for energy, capacity as well as renewable and environmental attributes of self-owned or third-party generation. Energy storage systems primarily affect the capacity, or electric demand, portion of these rates through their capability to curtail customer demand.

The North Carolina Utilities Commission has regulatory oversight over retail rates for investor-owned utilities, but not for electric membership cooperatives (coops) or municipally-owned electric systems (munis). The Commission and IOUs are also responsible for examining ways to control electricity demands during peak periods through rates that promote off-peak use, and educating the public on their options.<sup>3</sup> Most utilities offer flat rate pricing, where monthly demand and consumption are charged on a per-kWh consumption rate that blends the costs for the separate components. In general, rates that more closely reflect the actual cost of energy and capacity provide a clearer economic signal to customers to reduce consumption, and importantly for storage, reduce peak demand. Presently there are several types of retail electric rates in NC that are setup to promote the reduction of customer demand at peak times.

### Time-of-use (TOU) rates

These rates typically define daily on-peak and off-peak demand periods during summer, winter, and shoulder seasons. Energy charges are higher for on-peak and lower for off-peak kWh usage in order to incentivize customers to shift usage to off-peak times. A customer's highest monthly on-peak demand in kW, in some cases for a 15-minute interval, determines the demand charge each month. As shown in Table 6.1.2, utilities with TOU rates in NC include all IOUs, some munis, and one of the coops. The IOUs and some munis offer TOU rates to all customer classes: industrial, commercial and residential. An energy storage device for a customer on a TOU rate would need to reduce electric demand on a daily basis during the defined on-peak periods to have a significant financial benefit. On-peak hours for TOU rates amount to approximately half of all hours per year, during which energy storage systems must be controlled to limit demand to a preset target level to control costs.

**Table 6.1.2.** Utilities in North Carolina with time-of-use rates<sup>a</sup> from OpenEI, [https://openei.org/wiki/Utility\\_Rate\\_Database](https://openei.org/wiki/Utility_Rate_Database).

	Time of Use			Demand Management		CP		RTP
	Industrial	Commercial	Residential	Industrial	Commercial	Industrial	Commercial	Industrial
IOUs (4 total)	4	4	4	4	4	-		4
Munis (73 total)	14	11	7	5	11	20	14	-
Coops (26 total) <sup>b</sup>	1	1	-	-	-	1	1	-
Total								

<sup>a</sup> Numbers represent individual utilities, and some utilities may have multiple rates under each classification.

<sup>b</sup> Data in OpenEI is not complete for NC Cooperative utilities.

The TOU rates offered by Duke Energy Progress are representative of the design of TOU rates, and are available to any commercial or institutional customer with an average monthly demand greater

<sup>3</sup> North Carolina General Statutes § 62-155. Electric power rates to promote conservation.

than 30 kW. Table 6.1.3 shows the basic demand and energy charges under these rates, which were used in the analysis later in this section.

**Table 6.1.3.** Duke Energy Progress TOU Rates

Rate	Customer Monthly Demand Requirement (kW)	Peak Demand Charge (\$/kW/month)	Energy Charge (\$/kWh)
Duke Energy Progress	>30	\$10.78 summer <sup>a</sup>	\$0.05920 on-peak <sup>b</sup>
SGS-TOU-50	<1000	\$9.10 winter <sup>a</sup>	\$0.04695 off-peak <sup>b</sup>
Duke Energy Progress	>1000	\$20.40 summer <sup>a</sup>	\$0.05027 on-peak <sup>b</sup>
LGS-TOU-50		\$915.26 winter <sup>a</sup>	\$0.04527 off-peak <sup>b</sup>

<sup>a</sup>Summer months – June through September, Winter months – October through May.

<sup>b</sup>Peak hours, Summer - 10am-10pm, Winter – 6am-1pm & 4pm-9pm.

### Coincident peak (CP) rates

CP rates have two demand charges; one for the customer's maximum monthly 15-minute demand (kW) and another for the customer's average demand during the monthly coincident peak hour, defined as the hour in which the supplying utility's system peak demand occurs for the month. Table 6.1.4 shows a sampling of CP rates for municipal utilities in NC, all of which apply to industrial and commercial customers only. Presently, none of the IOUs have established CP rates for retail customers, though wholesale power contracts that the IOUs have with munis and some coops are based on CP pricing.

**Table 6.1.4.** Sampling of coincident peak rates for utilities in North Carolina

	Customer Peak Demand Requirement (kW)	Coincident Peak Demand Charge (\$/kW/month)	Customer Peak Demand Charge (\$/kW/month)	Energy Charge (\$/kWh)
City of Wilson (Schedule FR-MGS-2)	>35 & <500	\$23.39	\$5.00 <sup>a</sup>	\$0.0650
City of Wilson (Schedule FR-1-1)	>500 & <10,000	\$20.50	\$4.10 <sup>a</sup>	\$0.0570
Fayetteville PWC (Pilot CP Rate) <sup>b</sup>	>1000	\$20.11	\$2.00	\$0.04098
Greenville Utilities (Schedule MGS-CP)	>35 & <750	\$17.00	\$15.61	\$0.03027
Greenville Utilities (Schedule LGS-CP)	>750	\$22.20	\$13.13	\$0.02524

<sup>a</sup> Charged for excess demand, which is the difference between the customer's monthly peak demand and coincident peak demand.

<sup>b</sup> Fayetteville PWC CP rate is a pilot for May 2018-April 2019. A rate for large customers is proposed starting in May 2019.

The CP hour for each month is regularly forecasted by utilities to help them plan for dispatch of generation resources and load curtailment. There are also companies that provide a CP prediction

service, alerting clients several times per month when a coincidental peak might occur so they can reduce demand. An energy storage system need only produce output for 2-4 hours on possible CP days each month to yield a financial benefit. In general, there are from 100-200 hours during a year for which an energy storage system would be called to discharge.

### **Real time pricing (RTP)**

The energy rates under a RTP tariff vary hourly and are determined based on a utility's marginal energy cost and capacity charges. This rate is only available from IOUs in NC to a limited number of customers with contract demand above 1000 kW. Typically, customers will have a minimum baseline that is charged at general large service rates, with consumption above the baseline charged at RTP rates. The customer is sent the rates a day ahead by the utility, allowing them to plan to reduce demand accordingly. Energy storage systems can yield significant potential benefits under an RTP tariff.

There are a limited number of large customers with the expertise and capability to respond to RTP price signals, and utilities place limits on the number of customers on RTP rates. Duke Energy Carolinas allows a maximum of 150 customers to be hourly pricing (HP) rate and Duke Energy Progress allows a maximum of 85 customers under their LGS-RTP rate (where LGS stands for Large General Service). Due to the unique and limited nature of larger sites that are on RTP, and the complexity and variability of RTP pricing, energy storage systems on RTP rates are not evaluated in this study.

### **6.1.2 Energy Storage Opportunities in Demand-side Management**

Demand-side management (DSM) programs also offer opportunities for investments in energy storage systems by electric customers. Utilities in North Carolina currently offer a range of DSM programs that fall into two primary categories: curtailment of loads and use of onsite generation to reduce demand. For residential and small customers, load curtailment using automated signaling and control, for example, to turn off water heaters and air conditioning units during peak periods, is an effective means of DSM. For large customers, especially industrial and institutional facilities, onsite control of demand through automatic or manual means is common. Utility control of standby generators on large customer sites for demand reduction during peak periods is also commonly practiced.

Two DSM programs currently offered by Duke Energy are:

- Demand Response Automation Curtailable Load:  $\$3.25/\text{kW}/\text{month} \times \text{contracted curtailable demand} + \$6.00/\text{kW}/\text{month} \times \text{sum of demand reduction events}$
- Standby Generator Control (Duke Energy Carolinas Tariff SG):  $\$10/\text{month} + \$2.75/\text{kW}$

Municipal utilities in North Carolina that have wholesale power contracts based on coincident peak pricing and employ CP rates use standby generators for peak shedding extensively. For example, in 2017, Electricities reported an estimated savings of \$60.8 million from CP reductions due to DSM/Load management (Electricities, 2018).

Due to the limited number of hours (typically < 200) that a DSM measure needs to be employed during a year, energy storage systems are ideal for DSM applications. Existing DSM programs in NC currently do not mention energy storage as a specific means to curtail load, such as in the case

of Duke Energy’s Demand Response Automation (DRA-7) rider, which states “eligible electrical equipment shall be identified by Company during a Site Survey.”

### 6.1.3 Cost-Benefit Analysis of Energy Storage for Large Energy Users

Large energy users include industrial, institutional, and commercial customers that have average or contracted baseload power demands greater than 1000 kW. These customers will usually be able to select from available rates that include flat rates, TOU, or CP pricing.

Large energy users with significant amounts of air-conditioned space will have load shapes with higher peak demands during summer periods of high utility demand. Often, large industrial sites, especially those without extensive air-conditioned facilities, have relatively consistent hourly loads and high load factors. Energy storage systems are most cost-effective for sites with TOU or CP pricing and larger fluctuations in demand.

Consider an example large customer site modeled using a typical site in SAM with an average monthly peak load of 1,603 kW, a winter peak of 1,559 kW, a summer peak of 1,688 kW and an annual load factor of 0.54. The load factor represents the ratio of the annual average load to average monthly peak demand for a customer site, calculated by dividing annual kWh consumed by the average peak demand load times the total number of hours in a year. Using the System Adviser Module, five scenarios of demand reduction applications are modeled as follows:

1. 500 kW<sub>AC</sub> solar PV roof mounted
2. 500 kW<sub>AC</sub> solar PV roof mounted + 500 kW<sub>AC</sub> 2-hour Li-ion Battery
3. 500 kW<sub>AC</sub> solar PV roof mounted + 500 kW<sub>AC</sub> 4-hour Li-ion Battery
4. 500 kW<sub>AC</sub> 2-hour Li-ion Battery
5. 500 kW<sub>AC</sub> 4-hour Li-ion Battery

As seen in Figure 6.1.2, the 500 kW solar PV system provides up to 92 kW of monthly peak demand reduction, while the 500 kW ESS provides nearly 500 kW of peak demand reduction.

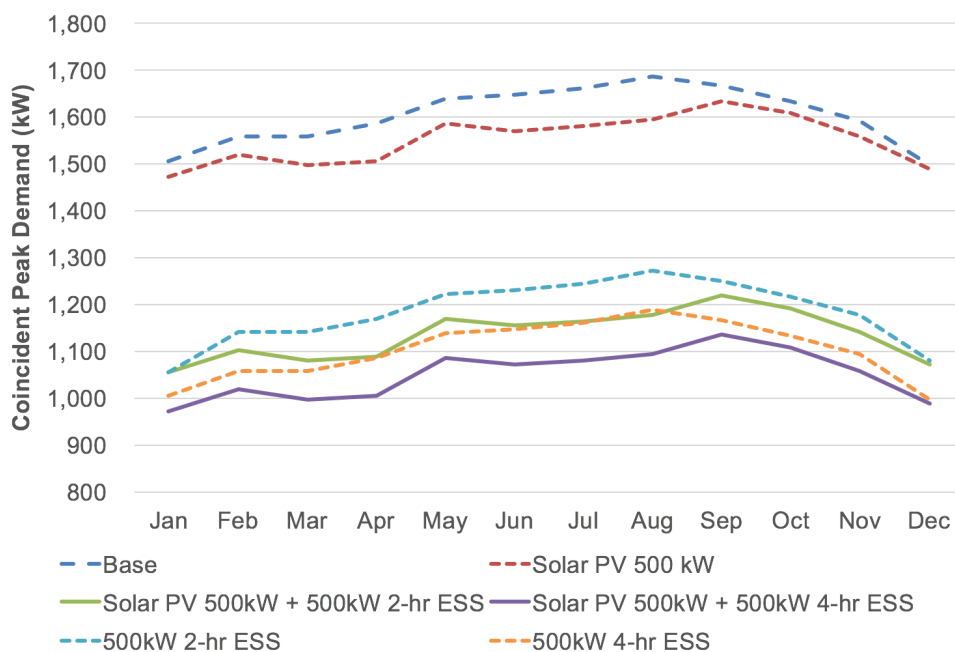


Figure 6.1.2. Large site demand reduction scenarios from System Adviser Module.

To determine potential benefits, each of these five scenarios were modeled using two representative rates for large energy users in NC: a CP rate (City of Wilson schedule FR-1-1) and a TOU rate (Duke Energy Carolinas LGS-TOU-50). For a coincident peak rate, we chose the City of Wilson FR-1-1 rate, which has one of the highest CP demand charges for municipal utilities in NC, thus enabling storage to deliver a potentially large economic benefit. The Duke Energy LGS-TOU rate, which has differentiation between on- and off-peak rates, is broadly representative of TOU rates within North Carolina.

The results from modeling energy storage on a large site with CP rate are shown in Table 6.1.5 below. Lithium-ion batteries are used for this analysis because they represent a commonly adopted storage technology. Costs are drawn from Section 4 of this report.

In our analysis of energy storage for large sites with CP rates, we assume the energy storage system produces output on demand during the coincident peak hour in 11 out of 12 months. This is based on what has been observed from the performance of other peak shaving technologies and coincident peak forecasting history.

**Table 6.1.5.** CP savings from energy storage for a large site under various scenarios

	Base	Solar PV	Solar PV + Storage	Storage Only		
Solar PV	0	500	500	500	0	0
Storage (kW)	0	0	500	500	500	500
Storage (kWh)	0	0	1000	2000	1000	2000
<b>System Output and Performance</b>						
Total Summer						
Peak	9,130	8,760	6,470	6,010	6,840	6,380
Total Winter Peak	11,110	10,840	7,860	7,260	8,090	7,540
Total Annual Grid						
Energy (kWh)	7,646,000	6,772,000	6,779,000	6,791,000	7,654,000	7,665,000
<b>System Costs and Savings</b>						
Total Utility Costs	\$924,000	\$853,000	\$751,000	\$731,000	\$822,000	\$802,000
Annual Utility						
Savings	\$-	\$71,000	\$173,000	\$193,000	\$103,000	\$122,000
Part of Savings						
from Storage			\$112,000	\$122,000	\$112,000	\$122,000

For the TOU rate, Table 6.1.6 below shows the modeling results for a large site on the Duke Energy Progress LGS-TOU-50 rate (see Table 6.3 above). In this analysis, the energy storage system was modeled as shifting approximately 90% of its capacity during times when the site power was near the monthly peak, effectively limiting the site's monthly peak demand.



**Table 6.1.6.** TOU savings for a large site under various scenarios

	Base	Solar PV	Solar PV + Storage		Storage Only	
Solar PV	0	500	500	500	0	0
Storage (kW)	0	0	500	500	500	500
Storage (kWh)	0	0	1000	2000	1000	2000
Total Summer						
Peak	9,130	8,760	6,470	6,010	6,840	6,380
Total Winter Peak	11,110	10,840	7,860	7,260	8,090	7,540
Total Annual Grid						
Energy (kWh)	7,646,000	6,772,000	6,779,000	6,791,000	7,654,000	7,665,000
<b>System Costs and Savings</b>						
Total Utility Costs	\$728,000	\$675,000	\$583,000	\$565,000	\$636,000	\$619,000
Annual Utility						
Savings	\$-	\$53,000	\$145,000	\$163,000	\$92,000	\$110,000
Part of Savings						
from Storage			\$101,000	\$110,000	\$101,000	\$110,000

The results in Tables 6.1.5 and Table 6.1.6 are summarized in terms of annual cost, benefits, and net benefits (i.e., benefits – costs) below in Table 6.1.7.

Comparing the economic performance of the modeled storage scenarios under the CP rate and TOU rate, as shown in Table 6.1.7 below, leads to several insights:

- There is a net positive benefit in the 2-hour scenario, assuming 2019 battery costs under the CP rate as well as the TOU rate.
- Systems performed better under CP rates than TOU rates, with higher net benefits.
- With or without solar PV, the Li-ion batteries had similar levels of performance since there is still a large peak demand to shave.
- The benefits for the 2030 battery costs exceeded revenue requirements by as much as 79%.

**Table 6.1.7:** Potential large customer benefits from li-ion battery energy storage

		Solar PV 500kW + 500kW 2- hr ESS	Solar PV 500kW + 500kW 4-hr ESS	500kW 2-hr ESS	500kW 4-hr ESS
<b>Li-Ion Energy Storage Benefit-Cost with Coincident Peak Rate</b>					
- Wilson Energy CP FR-1-1 tariff					
Benefit	\$/kWyr	\$225	\$244	\$225	\$244
Revenue Requirement (2019)	\$/kWyr	\$170	\$334	\$225	\$442
<b>Net Benefit (2019)</b>	<b>\$/kWyr</b>	\$55	\$(90)	\$0	\$(198)
Benefits	\$/kWyr	\$225	\$244	\$225	\$244
Revenue Requirement (2030)	\$/kWyr	\$126	\$247	\$126	\$247

<b>Net Benefit (2030)</b>	<b>\$/kWyr</b>	\$99	\$(3)	\$99	\$(3)
<b>Li-Ion Energy Storage Cost/Benefit with Time of Use Rate</b>					
- Duke Energy Carolinas Large General Service TOU rate LGS-TOU-50					
Benefit	\$/kWyr	\$202	\$220	\$202	\$220
Revenue Requirement (2019)	\$/kWyr	\$170	\$334	\$225	\$442
<b>Net Benefit (2019)</b>	<b>\$/kWyr</b>	\$32	\$(115)	\$(22)	\$(222)
Benefits	\$/kWyr	\$202	\$220	\$202	\$220
Revenue Requirement (2030)	\$/kWyr	\$126	\$247	\$126	\$247
<b>Net Benefit (2030)</b>	<b>\$/kWyr</b>	\$77	\$(28)	\$77	\$(28)

#### 6.1.4 ESS Applications for Small- and Medium-Sized Customers

Medium-sized electric service is generally available for nonresidential customers that have less than 1000 kW in demand load, while small electric service is available to those non-residential customers with less than 30 kW in demand load. An example of a medium-sized electric service is a big-box retail store, such as Costco, Target, Walmart or Ikea. A small office or retail space having less than 5,000 ft<sup>2</sup> in floor area would typically have a small electric service.

#### Battery Energy Storage for Small- and Medium-Sized Customers

Consider an example medium customer site modeled using a typical site in SAM with an average monthly peak load of 529 kW, a winter peak of 514 kW, a summer peak of 557 kW and an annual load factor of 0.55. Using the System Adviser Module (SAM), five scenarios of demand reduction applications were modeled as follows:

1. 100 kW<sub>AC</sub> solar PV roof mounted
2. 100 kW<sub>AC</sub> solar PV roof mounted + 100 kW<sub>AC</sub> 2-hour Li-ion Battery
3. 100 kW<sub>AC</sub> solar PV roof mounted + 100 kW<sub>AC</sub> 4-hour Li-ion Battery
4. 100 kW<sub>AC</sub> 2-hour Li-ion Battery
5. 100 kW<sub>AC</sub> 4-hour Li-ion Battery

The performance and savings under the CP rate for Wilson Energy, FR-MGS-2 (see Table 6.1.4 above), for all five scenarios are shown in Table 6.1.8. This rate has one of the highest CP demand charges for municipal utilities in NC, which offers a large potential benefit to energy storage. No modeling was done for a TOU rate due to the limited use of TOU rates by medium or small sites.

**Table 6.1.8:** CP savings for medium site; base, with solar PV, PV+storage & storage only

	<b>Base</b>	<b>Solar PV</b>	<b>Solar PV + Storage</b>	<b>Storage Only</b>		
Solar PV	0	100	100	100	0	0
Storage (kW)	0	0	100	100	100	100
Storage (kWh)	0	0	200	400	200	400
<b>System Output and Performance</b>						
Total Summer						
Peak	6,350	5,590	4,590	4,390	5,290	5,150

Total Winter Peak	6,980	6,280	6,280	6,280	6,980	6,980
Total Annual Grid Energy (kWh)	2,523,000	2,348,000	2,350,000	2,350,000	2,525,000	2,525,000
<b>System Costs and Savings</b>						
Total Utility Costs	\$355,000	\$322,000	\$299,000	\$294,000	\$330,000	\$327,000
Annual Utility Savings	\$-	\$32,000	\$56,000	\$60,000	\$25,000	\$28,000
Part of Savings from Storage			\$26,000	\$28,000	\$26,000	\$28,000

Comparing the economic performance of the modeled storage scenarios under the CP rate and TOU rate, as shown in Table 6.1.9 below, there are several insights:

- There are net positive benefits in the 2-hour battery scenarios assuming 2019 costs under the CP rate, with net benefits up to 51% higher than the revenue requirement.
- With or without solar PV, the Li-ion batteries had similar levels of performance since there is still a large peak demand to shave.
- The benefits assuming the 2030 battery costs exceeded revenue requirements in all scenarios, with net benefits ranging from 13-104%.

**Table 6.1.9:** Potential medium customer benefits from Li-ion battery energy storage

		<b>Solar PV 100kW + 100kW 2-hr ESS</b>	<b>Solar PV 100kW + 100kW 4-hr ESS</b>	<b>100kW 2-hr ESS</b>	<b>100kW 4-hr ESS</b>
<b>Li-Ion Energy Storage Cost/Benefit with Coincident Peak Rate</b>					
- Wilson Energy CP FR-MGS-2 tariff					
Benefit	\$/kWyr	\$256	\$280	\$255	\$279
Revenue Requirement (2019)	\$/kWyr	\$170	\$334	\$225	\$442
<b>Net Benefit (2019)</b>	<b>\$/kWyr</b>	\$87	\$(54)	\$31	\$(163)
Benefits	\$/kWyr	\$256	\$280	\$255	\$279
Revenue Requirement (2030)	\$/kWyr	\$126	\$247	\$126	\$247
<b>Net Benefit (2030)</b>	<b>\$/kWyr</b>	\$131	\$33	\$130	\$31

### Thermal energy storage for Small- and Medium-Sized Customers

Energy storage in thermal form, either in ice or water, is a common behind-the-meter application in North Carolina. These thermal energy storage (TES) systems are used to provide cooling on demand to buildings and campuses with chilled water distribution. The typical operation of cooling TES involves the operation of chillers at night, during off-peak electric periods, to charge tanks containing water or a glycol solution. The latter is used when storing energy in an ice-based TES, which has the advantage of requiring 1/10<sup>th</sup> of the volume of chilled water TES systems. The cooling TES are used to provide cooling on demand during on-peak electric periods during the

cooling season, allowing electric chillers to operate in a reduced capacity or remain off altogether during peak periods.

Common sites for cooling TES include government or higher education campuses, military bases, primary and secondary schools, large commercial building and industrial plants. One example is a 2.7 million gallon aboveground chilled water storage tank at the State of North Carolina government campus downtown Raleigh. This tank provides chilled water to over 3.5 million square feet across 20 buildings that house state agencies, offsetting over 2,500 kW of peak electric demand (Energy Storage Exchange, 2018). Many school systems, such as Cumberland County Schools and Wake County Public School System utilize ice-based TES at 50 sites (Ingersoll Rand).

To determine the potential net benefit of TES in North Carolina, an example secondary school site was modeled, with an average monthly peak load of 529 kW, a winter peak of 514 kW, a summer peak of 557 kW and an annual load factor of 0.55. A 100 kW equivalent cooling TES was chosen for simplicity. For reference, a TES of this size would provide approximately 185 tons of cooling, based on a minimum required full-load efficiency of 0.54 kW/ton for a new chilled water plant (State of NC Energy Code, 2018). Using a spreadsheet-based model, four scenarios of demand reduction applications were modeled as follows, with results shown in Table 6.1.10:

1. 100 kW<sub>TH</sub> TES, chilled water storage, coincident peak rate (Wilson Energy FR-MGS-2)
2. 100 kW<sub>TH</sub> TES, ice storage, coincident peak rate (Wilson Energy FR-MGS-2)
3. 100 kW<sub>TH</sub> TES, chilled water storage, coincident peak rate (Duke Energy LGS-TOU-50)
4. 100 kW<sub>TH</sub> TES, ice storage, coincident peak rate (Duke Energy LGS-TOU-50)

Note that there are no projections for lower costs of TES in 2030, since this is a mature technology.

**Table 6.1.10:** Medium site benefits with cooling TES under various scenarios

	Base Electric	Peak Cooling	Coincident Peak Rate (Wilson Energy FR-MGS-2)		Time of Use Rate (Duke Energy SGS-TOU-50)	
			Chilled Water	Ice	Chilled Water	Ice
Thermal Storage (kW)	0	0	100	100	100	100
Thermal Storage (Tons)	0	0	185	185	185	185
Duration (hours)	0	0	6	6	6	6
<b>System Output and Performance</b>						
Annual Peak Energy (kWh)	4,588,000	4,588,000	-	-	2,980,000	2,980,000
Annual Off-peak Energy (kWh)	3,059,000	3,059,000	7,646,000	7,646,000	4,667,000	4,667,000
<b>System Savings</b>						
Annual Utility Costs	\$582,000	\$473,000	\$537,000	\$537,000	\$444,000	\$444,000
Annual Utility Savings			\$46,000	\$46,000	\$29,000	\$29,000

Reviewing the modeled storage scenarios under the CP rate and TOU rates, as shown in Table 6.1.11 below, we observe the following:

- There are net positive benefits for 2018 TES costs under the CP rate, with net benefits as much as 112% higher than the revenue requirement.
- The economic performance of TES is worse under the TOU rate compared to the CP rate, with a negative net benefit for chilled water storage due to its higher maintenance costs

**Table 6.1.11:** Potential medium customer benefits from thermal energy storage; CP & TOU rates

		Coincident Peak Rate – City of Wilson FR-MGS-2		Time of Use Rate – Duke Energy Progress SGS-TOU-50	
		100 kW TES - Chilled Water	100kW TES - Ice	100 kW TES - Chilled Water	100 kW TES - Ice
Benefit	\$/kWYr	\$275	\$444	\$108	\$277
Revenue Requirement (2019)	\$/kWYr	\$266	\$209	\$266	\$209
<b>Net Benefit (2019)</b>	<b>\$/kWYr</b>	<b>\$9</b>	<b>\$234</b>	<b>\$(158)</b>	<b>\$67</b>

### 6.1.5 ESS Applications for Residential Customers

Presently, policies promoting energy storage utilization for demand reduction are the primary driver for deployment of behind-the-meter residential applications of energy storage, with California and Hawaii leading the way (Utility Dive, 2018). In North Carolina, no such policies exist, so there is limited value in the use of storage alone to reduce demand charges. Therefore, this analysis focuses on the use of storage with solar PV. Lithium-ion batteries were chosen for their longer lifetime and cycle count, although lead acid batteries are also appropriate for a residential application.

Table 6.1.12 below details residential current rates available from Duke Energy, including TOU rates that may offer energy storage opportunities. Customers are permitted to install non-fossil sources of energy, such as solar PV, to supplement their requirements under each of these three rates. Energy storage is not specifically mentioned as being permitted in the tariffs, but is assumed to be so long as it is charged from the solar PV only.

**Table 6.1.12.** Residential Rates: Duke Energy Progress (DEP) and Duke Energy Carolinas (DEC)

Rate	Monthly Customer Charge	On-Peak Demand Charge (\$/kW)	Summer Energy Charge (\$/kWh)	Winter Energy Charge (\$/kWh)
DEP Residential	\$14.00	n/a	\$0.1042	\$0.09947
RES-50			July - October	November-June
DEP TOUD (Demand)	\$16.85	\$4.88 Jun-Sep \$3.90 Oct-May	\$0.07172 on-peak \$0.05732 off-peak	\$0.07172 on-peak \$0.05732 off-peak
R-TOUD-50			June - September	October - May

DEP TOU (Energy) R-TOU-50	\$16.85	n/a	\$0.23507 on-peak \$0.11996 shoulder \$0.07036 off-peak June - September	\$0.22356 on-peak \$0.11708 shoulder \$0.07063 off-peak October - May
DEC Residential RS	\$14.00	n/a	\$0.087226 July - October	\$0.087226 November-June
DEC Residential w/electric water heating and air conditioning RE	\$14.00	n/a	\$0.085855 July - October	\$0.085855 first 350 kW \$0.076408 all over 350 kW November-June

<sup>a</sup> Charged for excess demand, which is the difference between the customer's monthly peak demand and coincident peak demand.

The System Adviser Module was used to evaluate a typical residential home in NC with a PV system sized to produce annual output equal to 84% of projected household electric consumption. Due to the fact that solar PV produces much of its output during the day, when residential loads are typically low and excess power is exported to the grid, this system was assumed to be on a net-metering tariff. The hypothetical residence was modeled with and without solar PV and storage, under scenarios representing each of three Duke Energy Progress rates in Table 6.1.12. It should be noted that for the DEP RES and TOUD-50 tariffs, the baseload costs are similar, while for the TOU-E tariff, the baseload cost is much higher due to high on-peak energy charges. Therefore, while the results for TOU-E are included here, it is not likely that a typical homeowner would choose this rate. Table 6.1.13 contains the detailed results.

**Table 6.1.13:** Residential benefits with solar PV and storage under various scenarios

	Baseload			With Solar PV and Storage		
	Duke Energy Progress RES Tariff	Duke Energy Progress TOUD-50	Duke Energy Progress TOU-E	Duke Energy Progress RES Tariff	Duke Energy Progress TOUD-50	Duke Energy Progress TOU-E
Solar PV	0	0	0	4.0	4.0	4.0
Storage (kW)	0	0	0	3.0	3.0	3.0
Storage (kWh)	0	0	0	4	4	4
<b>System Output and Performance</b>						
Electricity from Grid (kWh)	9,029	9,029	9,029	1,401	1,401	1,401
Electricity from PV (kWh)				7,628	7,628	7,628
<b>Utility costs and Savings</b>						
Annual Utility Costs	\$1,090	\$860	\$5,270	\$390	\$420	\$1,990
Annual Utility Savings				\$700	\$450	\$3,280

From the cost-benefit results of this analysis, shown in Table 6.1.14, we observe that none of the solar and battery storage scenarios have a positive net benefit with current or future costs.

**Table 6.1.14:** Potential residential customer benefits from solar PV & storage; Duke Energy Progress Rates

	Rate	3 kW 4-hr ESS DEP RES Tariff	3 kW 4-hr ESS DEP TOUD-50	3 kW 4-hr ESS DEP TOU- E
Benefit	\$/kW-yr	\$(6)	\$9	\$63
Revenue Requirement (2019)	\$/kW-yr	\$412	\$412	\$412
<b>Net Benefit (2019)</b>	<b>\$/kW-yr</b>	<b>\$(418)</b>	<b>\$(403)</b>	<b>\$(349)</b>
Benefits	\$/kW-yr	\$(6)	\$9	\$63
Revenue Requirement (2030)	\$/kW-yr	\$294	\$294	\$294
<b>Net Benefit (2030)</b>	<b>\$/kW-yr</b>	<b>\$(300)</b>	<b>\$(285)</b>	<b>\$(231)</b>

Despite the lack of a net benefit resulting from utility savings, the application of residential energy storage is still of interest to residential customers who want a backup power source in case of a grid outage. For shorter duration outages of several hours or less, energy storage alone is a viable solution. For outages lasting over 4 hours or even several days, which may occur during severe weather events, such as hurricanes, storage coupled with solar PV could provide sufficient electricity to meet critical household demands.

### Implications of Behind-the-Meter Storage in NC

The potential demand reduction benefits of customer-owned storage to the utility grid in North Carolina are verifiable, and for some storage technologies, such as chilled-water and ice-based thermal storage, there has been adoption in proven applications. Newer energy storage technologies, such as batteries have increasing deployment potential based on recent downward price trends.

To create conditions for the development of customer-owned behind-the-meter storage requires, among other things, properly designed tariffs. CP rates should send proper price signals reflecting the cost of displaced peak capacity, while the TOU rates should be designed reflect time varying marginal electricity prices. As the market penetration of customer-owned storage increases, the changes in the aggregate load profile may require the revision of tariffs.

### **Alternative Energy Storage Business Models for Utilities: Green Mountain Power and Tesla Powerwall**

Green Mountain Power (GMP) is an investor owned utility in Vermont, with nearly 1,000 miles of transmission lines, ownership stakes in a variety of generating technologies, and large and small power purchase agreements needed to serve much of the state's electricity demand (Green Mountain Power, 2014). In 2015, GMP launched a pilot-scale partnership with Tesla to offer their residential customers behind-the-meter energy storage with its Powerwall product. Tesla's Powerwalls are lithium-ion batteries, with the latest version offering peak output of 7 kW and 13.5 kWh of storage capability (Tesla, 2018).

When considering this partnership, GMP believed that its customers would value several services provided by the Powerwall. Namely, participating customers could use these batteries for emergency backup, load shifting (which would be attractive to customers on time of use rates), and to increase solar self-consumption. A variety of ownership and operational approaches were considered (Kraus, 2017). The pilot program, which has reached capacity with 2,000 participants, allows GMP to own the Powerwalls, with the customers paying \$1,500 upfront or \$15 per month for a ten year period (Green Mountain Power, 2018a).

Because these batteries are utility-owned assets, the design of this program allows GMP to earn a return on customer-sited investments (Kraus, 2017). Facing declining electricity demand, this ownership structure presents GMP with a novel means to increase its rate base and earning potential. GMP retains some operational control of these batteries, primarily to provide generation during peak hours and reduce the need for firm generation capacity (Kraus, 2017). The cost to participating customers is designed to reflect the investment cost of the Powerwall and the system benefits of peak generation capacity displacement (Kraus, 2017). The intended outcome is that non-participating customers will see no increase in their bills as a result of this program. While this program is still modest in size, its success suggests the viability of a business model where utilities own behind-the-meter storage that can provide grid services, and customers are willing to pay for emergency backup, load shifting and increased solar self-consumption.

In addition to the utility-owned behind-the-meter energy storage model, GMP also offers a "bring your own device (BYOD)" program (Green Mountain Power, 2018b). Through this program, customers own and operate their storage devices for backup power and other applications. In exchange for sharing operational control with GMP during peak demand hours, customers receive a bill credit. Current eligible devices include the Tesla Powerwall 2.0, Sonnen Battery, Sunverge Battery, and SolarEdge StorEdge systems. The peak events for which GMP would utilize these batteries are expected to occur five to eight times per month, with each event lasting three to six hours. Bill credits range from \$14.50/month to \$36.00/month, less a \$2.50/month integration fee (Green Mountain Power, 2018b).

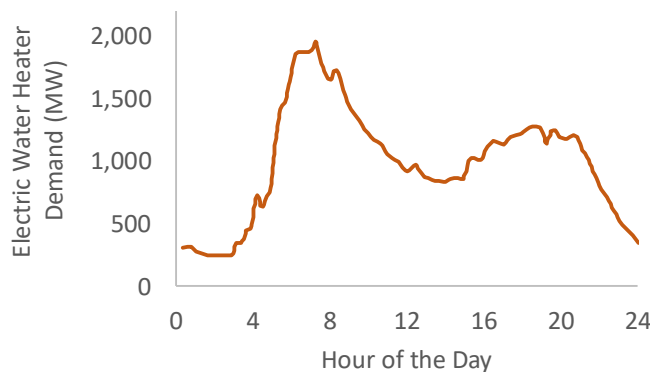


## Water Heaters: Energy Storage That We Already Have

Traditional water heaters pre-heat and store water to ensure that it is available when needed. Through demand response programs, utilities or other companies can shift the timing of when the water is heated to avoid peak hours or otherwise expensive times. Such programs can be designed to ensure that the shifted water heating schedule does not adversely impact the availability of hot water, while effectively serving as thermal storage for the grid. North Carolina Electric Cooperatives have successfully demonstrated the ability of residential water heaters to serve as a power grid resource. Through two-way communication systems, this pilot project reduced demand 0.45 kW per water heater in the summer and 0.90 kW per water heater in the winter (Advanced Energy, 2018).

Using publicly available data, we estimate the magnitude and timing of the potential for load shifting using electric water heaters. The U.S. Energy Information Administration's Residential Energy Consumption Survey found that 71% of households in the South Atlantic region (which includes NC) have an electric water heater and the annual average electricity consumption is 3,043 kWh per household that has an electric water heater (U.S. Department of Energy, 2018b). The US Census estimates that there are 3.8 million households in North Carolina in 2017 (U.S. Census Bureau, 2018), which would equate to approximately 2.7 million households with electric water heaters. This would imply 8.2 TWh of electricity consumed per year in North Carolina heating residential water.

While the *average* electricity consumption for water heating in North Carolina would be 940 MW, the actual value would vary considerably throughout the day. To estimate the daily consumption pattern and the correspondence to peak demand, we use data from the predicted diurnal electricity consumption patterns generated by Pacific Northwest GridWise Testbed Demonstration Projects (Hammerstrom, 2007). Our results are scaled assuming 2.7 million households with electric water heaters and shown in Figure 6.1.3.



**Figure 6.1.3.** Estimated electricity demand from NC residential electric water heaters on a typical day.

As seen in Figure 6.1.3, there is a peak of 2 GW of electric water heater demand in the morning (approximately 7:15 am) and a secondary peak in evening demand of 1.3 GW (approximately 6:00 to 7:00 pm). The all-time peak demand for electricity in Duke Energy Carolinas occurred on a winter day between 7:00 and 8:00 am (Duke Energy, 2018b), which corresponds to our calculated water heater peak load. This suggests that there is great potential to reduce peak system demand through water heater demand response. While it is unlikely that the full 2 GW for peak water heating could be displaced, there is still considerable potential for peak load reduction.

## References

- Advanced Energy (2018) <https://www.advancedenergy.org/2018/08/09/ncemcandcarina/>.
- Duke Energy (2018a) Retail Electric Rates. <https://www.duke-energy.com/home/billing/rates>.
- Duke Energy (2018b), <https://news.duke-energy.com/releases/duke-energy-carolinas-customers-set-new-all-time-peak-record-for-energy-use>.
- Electricities (2018). 2017 Explanation of Value Delivered [to Members]. [http://www.electricities.com/ElectriCities\\_Value/value-delivered.html](http://www.electricities.com/ElectriCities_Value/value-delivered.html)
- Energy Storage Exchange (accessed October 2018). Database maintained by the U.S. Department of Energy Office of Electricity Delivery & Reliability. <https://www.energystorageexchange.org/projects/76>.
- Green Mountain Power (2014) Integrated Resource Plan.
- Green Mountain Power (2018a). <https://greenmountainpower.com/help/products-services/gmp-tesla-powerwall-offer>, accessed November 16, 2018.
- Green Mountain Power (2018b), <https://greenmountainpower.com/news/gmp-offers-new-bring-device-program-cut-energy-peaks/>, accessed November 16, 2018.
- Hammerstrom, Donald J., et al. (2007). Pacific Northwest Gridwise testbed demonstration projects; part ii. grid friendly appliance project. No. PNNL-17079. Pacific Northwest National Lab.(PNNL), Richland, WA (United States).
- Ingersoll Rand Inc., Calmac Division (February 2018). List of ice storage projects in North Carolina.
- Kraus, A., Mashburn, B., and Johnson, J., (2017). Michigan Sustainability Cases, Can Tesla's home battery help modernize Green Mountain Power's grid?, <https://www.learnala.com/cases/tesla-powerwall>.
- North Carolina Energy Conservation Code (2018 Proposed). [http://www.ncdoi.com/OSFM/Engineering\\_and\\_Codes](http://www.ncdoi.com/OSFM/Engineering_and_Codes).
- OpenEI Website (accessed September 2018). Maintained by the National Renewable Energy Laboratory for the U.S. Department of Energy. *Utility Rate Database*, <http://www.openei.org>.
- Regulatory Assistance Project (August 2018). *With Sinking Storage Costs, Big-Box Solar Could Really Take Off*. <http://www.raponline.org>.
- Smith AJ, Brown CD, Doe, JA (2017). *The growing importance of storage*. Energy Policy, 23(10): 199-205.
- System Adviser Module version 2017.9.5. Maintained by the National Renewable Energy Laboratory for the U.S. Department of Energy. Available at <http://sam.nrel.gov>.
- Tesla (2018). <https://www.tesla.com/powerwall>, accessed November 16, 2018.
- U.S. Census Bureau (2018), <https://www.census.gov/quickfacts/nc>.
- U.S. Department of Energy (2018a), Energy Information Administration. <http://eia.gov>.

U.S. Department of Energy (2018b), Energy Information Administration, Residential Energy Consumption Survey, <https://www.eia.gov/consumption/residential/data/2015/index.php>.

Utility Dive (September 2018). *In first US residential energy storage overtakes front-of-meter installations*. <http://www.utilitydive.com/news/in-first-us-residential-energy-storage-overtakes-front-of-meter-installati/531682/>.

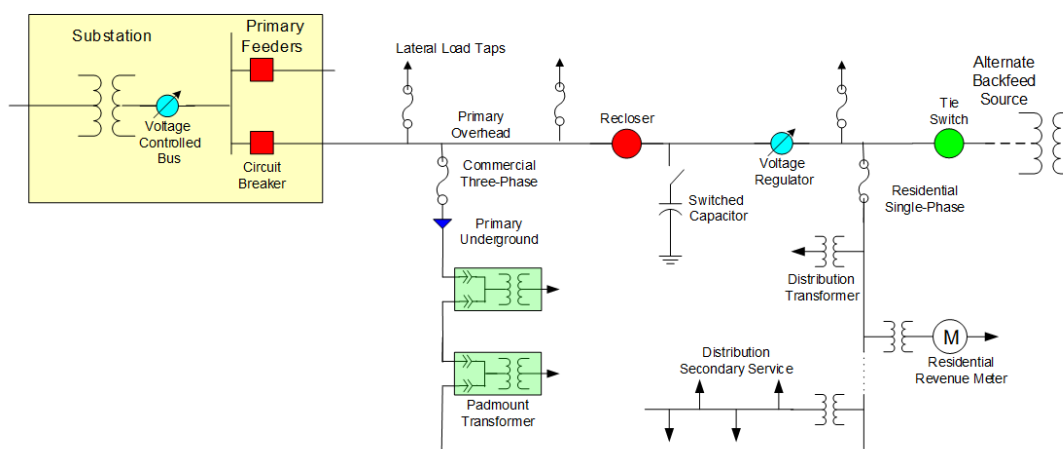
Wilson Energy (2018) Retail Electric Rates. <https://www.wilsonnc.org/wilson-energy/>

## 6.2. Distribution Services

### 6.2.1 Background

In this section of the report, we focus on the value of utilizing energy storage on an electric utility power distribution circuit. A distribution circuit provides the connection between a high-voltage transmission system and low-voltage electric customers. See Figure 6.2.1 for key elements of a distribution circuit. Starting at the distribution substation, a utility uses a combination of overhead pole-mounted lines and underground cables to deliver electricity to the customer's service transformers. Storage located at the distribution level is typically utility owned and operated.

This section uses several hypothetical case studies to demonstrate the value of placing energy storage on a medium-voltage distribution system. Each case study includes an estimate of energy storage value and a representative benefit-cost analysis. Potential locations for storage include the substation, along the distribution feeder, at a customer distribution transformer or at a PV array. In particular, we look at three scenarios involving capacity deferral/peak shaving, customer reliability enhancement, and high-penetration distributed energy resource (DER) voltage control, which are summarized below.

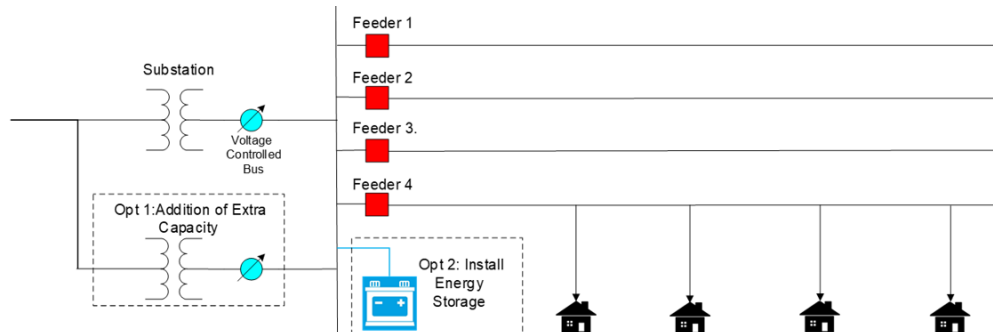


**Figure 6.2.1.** Distribution circuit components. The distribution system starts at the substation where high voltage transmission is converted to medium voltage and routed to the load points via overhead and underground cables. Voltage regulators and capacitor banks are used to help regulate the voltage until it is converted to a customer utilization level at the customer distribution transformers.

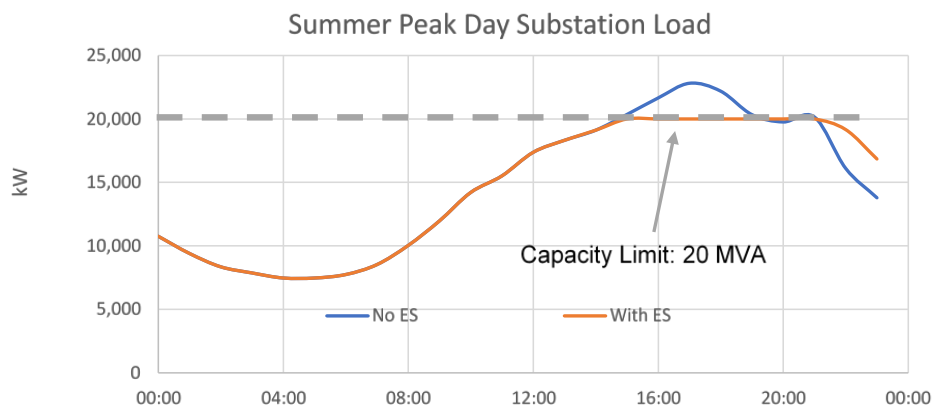
### Capacity Deferral and Peak Shaving

Capacity deferral and associated peak shaving involves using distribution-sited storage to control peak demand at the distribution circuit level in order to defer an expensive bulk capacity upgrade and also achieve associated monthly peak shaving. Circuit loads normally increase each year due to annual incremental growth or the addition of large new loads. Storage can be utilized to defer substation and distribution feeder upgrades, reduce peak demand, and help to support operation of the sub-transmission (69 to 115 kV) and transmission systems. Figure 6.2.2 shows two options for substation upgrade: Option 1 involves adding another substation transformer, which typically comes in a bulk

size; Option 2 involves installing an energy storage unit at the substation to supply electricity over short periods in order to delay or defer the need for an upgrade. Figure 6.2.3 shows an example of using energy storage for capacity deferral where the capacity limit is 20 MVA and it is a summer peak day. Energy storage will discharge to avoid overloading the substation.



**Figure 6.2.2.** Substation upgrade scenario. Option 1 represents a traditional capacity upgrade, and Option 2 represents the installation of energy storage.

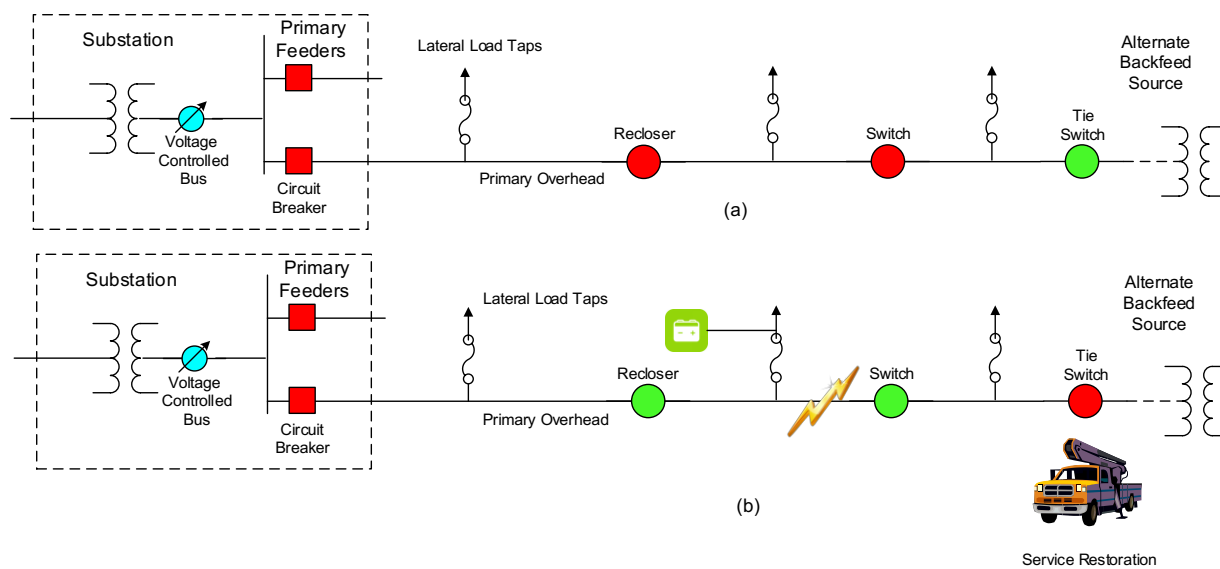


**Figure 6.2.3.** Substation peak shaving using energy storage. The dotted line indicates the substation capacity, and the blue and orange lines indicate the substation load on a peak summer day.

### Reliability Enhancement

Reliability enhancement involves the use of energy storage to improve customer system average interruption frequency index (SAIFI) and system average interruption duration index (SAIDI). This could involve using energy storage to support alternate power feeds during feeder reconfiguration or siting storage near customers to support microgrid operation during grid outages.

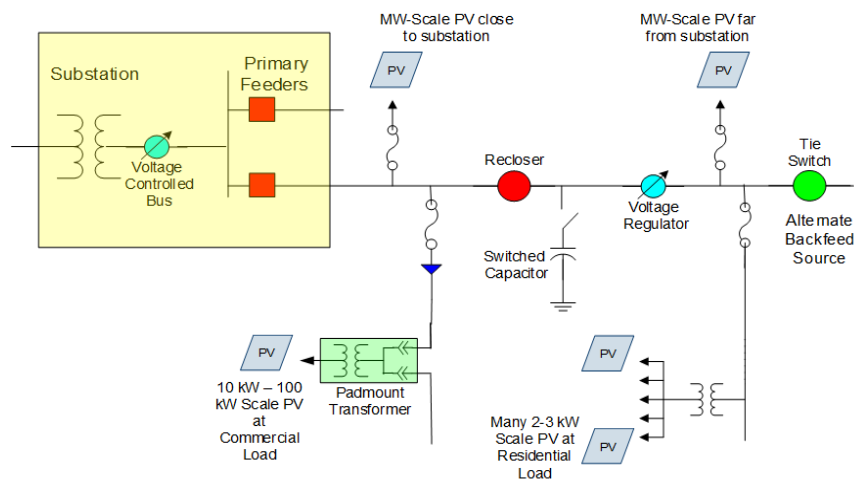
A basic distribution circuit scenario is shown in Figure 6.2.4. When a fault occurs on the circuit, the utility needs to first isolate the faulted section so it can be repaired. While service can be restored upstream of the faulted area, customers downstream of the fault or in the faulted area remain without power. A downstream customer can be served by either an alternate backfeed source (i.e., a second circuit connected by a tie switch) if it exists or distributed generation in the form of an energy storage system or conventional backup generator.



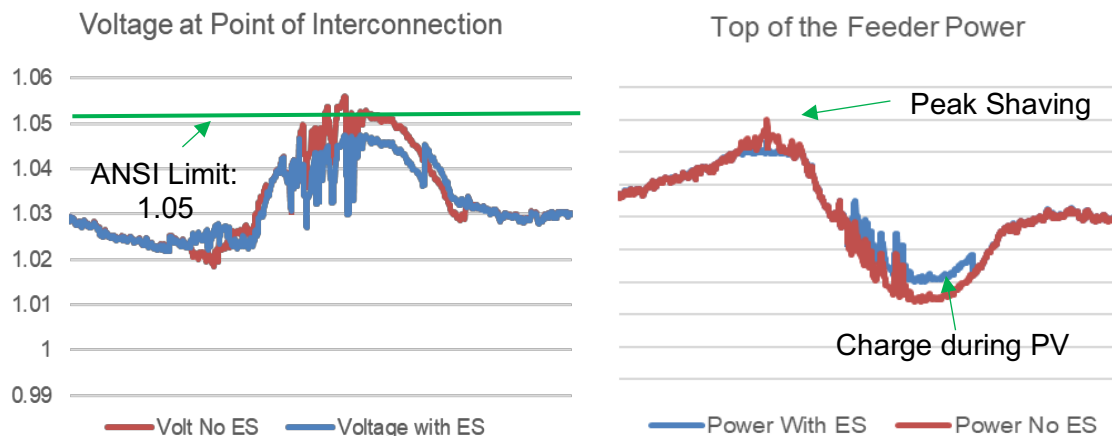
**Figure 6.2.4.** Distribution reliability scenario (a) before the fault (b) after the fault (red indicates closed and green indicates open).

### Voltage Control for High Penetrations of Solar

This application includes the use of storage to aid voltage control in a distribution system with a high-penetration of solar PV. Figure 6.2.5 illustrates an example feeder with various PV units connected to the distribution system. The application of energy storage in this section could involve smoothing the output of an intermittent PV source, absorbing PV output during light loading conditions to reduce voltage, and performing peak shaving. Figure 6.2.6 shows an example feeder that experiences overvoltage due to the addition of PV. The fact that the PV system pushes power towards the substation causes a rise in the circuit voltages. Adding energy storage helps to mitigate the overvoltage issue by charging (adding more load) to counteract the voltage increase caused by PV generation. An additional benefit is if the energy storage is discharged during peak hours, this can also create additional peak shaving during a system load peak.



**Figure 6.2.5.** Example circuit layout with several connected solar PV units.



**Figure 6.2.6.** Solar PV impact on bus voltage at the interconnection point.

## 6.2.2 Methodology

### Capacity Deferral and Peak Shaving

When load starts to exceed capacity loading limits, the traditional approach is to upgrade the substation or piece of equipment being overloaded. Since we typically want to account for future growth, this can involve upgrading the circuit to 1.25 to 2 times its original capacity. If the added capacity need is small, then an upgrade is an expensive solution to meet short-term needs. So another means of adding a small amount of extra capacity is preferred until load growth makes the traditional upgrade more economical. Using energy storage is one way of deferring the upgrade.

This hypothetical case study examines the placement of energy storage at the substation to achieve capacity deferral and optimal monthly peak shaving. Key assumptions for the feeder simulation are shown in Table 6.2.1.

**Table 6.2.1.** Capacity Deferral/Peak Shaving Feeder Simulation Assumptions

Feeder Simulation	
Annual Load Curve	Hourly (Hoke, 2017)
Capacity	20 MVA
Number of Feeders	4
Annual Load Growth Rate	1%
Coincident Peak (yr.1-10)	20.3 MW – 22.2 MW
Energy Storage	Added in 500kW blocks

The capacity limit of the substation with four feeders is 20 MVA, as shown in the circuit diagram used to perform the reliability analysis (Figure 6.2.7). The annual load curves used in this study represent southeast utilities with a coincident peak of 20.3 MW at year one. A 1% annual load growth is

considered. The study is performed for 10 years with a discount rate of 10%. The maximum life of the utility scale lithium-ion battery used in the study is 20 years and includes annual augmentation and warranty costs. Since lithium-ion batteries usually come in discrete sizes, we add the batteries in 500 kW blocks in our study.

Hourly simulation is performed in Excel using VBA programming. Energy storage is added in 500 kW blocks each year as needed to make sure the system is not overloaded and the capacity upgrade can be deferred. Then the optimal monthly peak shaving settings are solved to achieve the maximum peak shaving benefits. These peak shaving settings are used for energy storage discharge control. The energy storage unit monitors the substation loading and if the limit is reached, it will discharge to shave the load if any stored energy is available. Note that when we do capacity deferral, we have already shaved the peak enough to meet the 20 MVA limit. In the second step, which can achieve additional peak shaving benefits, the peak shaving amount is set to be lower than the monthly peak value to reduce the monthly peak even more. The mathematical model is formulated as follows:

$$\text{Min} \quad \sum_{\text{Year } i=1}^N \sum_{\text{Month } j=1}^{12} (\text{Peak}_{ij} \times \text{Demand Charge}_j)$$

$$\text{s. t.} \quad \text{Peak}_{ij} = \underset{\substack{\text{Day in Month } j \\ \text{hour } k=1 \text{ to } 24}}{\text{Max}} (\text{Load}_{\text{Day},k} + \text{Charge}_{\text{Day},k} - \text{Discharge}_{\text{Day},k}) \quad (1)$$

$$\text{Charge}_{\text{Day},k} = \text{ESkWhRating} \times (\text{SOC}_{\text{target}} - \text{SOC}_{\text{Day},k}) \quad (2)$$

$$\text{Discharge}_{\text{Day},k} = \text{Load}_{\text{Day},k} - \text{PeakSetting}_{ij} \quad (3)$$

$$\text{Charge}_{\text{Day},k} \leq \text{PeakSetting}_{ij} - \text{Load}_{\text{Day},k} \quad (4)$$

$$\text{Charge}_{\text{Day},k} \leq \text{ESkWhRating} \times (1 - \text{SOC}_{\text{Day},k}) \quad (5)$$

$$\text{Discharge}_{\text{Day},k} \leq \text{ESkWhRating} \times \text{SOC}_{\text{Day},k} \quad (6)$$

$$\text{SOC}_{\text{Day},k+1} = \text{SOC}_{\text{Day},k} + \text{Charge}_{\text{Day},k} \times \text{Eff} - \text{Discharge}_{\text{Day},k} \div \text{Eff} - \text{SelfDischarge}_{\text{Day},k} \quad (7)$$

$$\text{SelfDischarge}_{\text{Day},k} = \text{ESkWhRating} \times \text{SOC}_{\text{Day},k} \times \text{Rate}_{\text{self}} \times (\text{Charge}_{\text{Day},k} = 0) \times (\text{Discharge}_{\text{Day},k} = 0) \quad (8)$$

$$0 \leq \text{Charge}_{\text{Day},k}, \text{Discharge}_{\text{Day},k} \leq \text{ESkWhRating} \quad (9)$$

In the simulation, the charge control is trying to keep the state of charge (SOC) of the energy storage at 80% so that the energy storage can discharge when needed. The discharge is controlled by the peak shaving settings and it can have a different value every month. These settings are optimized to achieve



the maximum peak shaving benefit each month. The maximum charge or discharge rate is the kW capacity defined for the energy storage.

For this analysis of capacity deferral and peak shaving, we consider a 4-hour, utility scale lithium-ion battery. The cost per kWh of storage is \$369 for 2019 and \$200 for the year 2030, based on the estimates provided in Section 4. Consistent with Section 4, we also consider a \$15/kWyr fixed O&M cost. The round trip efficiency is 85% and there is a self-discharge considered. The simulation and cost parameters for the Li-ion battery are listed in Table 6.2.2.

**Table 6.2.2. Energy Storage Simulation and Cost Parameters**

<b>Energy Storage (Li-ion 4 hr)</b>	
Cost (\$/kWh)	369 (200 for 2030)
O&M Cost	15 \$/kWyr
Augmentation + Warranty 2019	78 \$/kWyr
Augmentation + Warranty 2030	35.7\$/ kWyr
Life	20 Years
Round trip efficiency	85%
Loan Rate	10%

To increase the value proposition of storage on the distribution network, we stack the capacity deferral benefits and the monthly peak shaving savings since the capacity deferral requires a very low utilization of the relatively large energy storage unit, likely a couple hours per year.

The single-year deferral benefit is calculated in the example study. This part of the benefits is defined as the utility's annual revenue requirement for the upgraded T&D facility. Note that if a T&D upgrade project is deferred, then the avoided payment is treated as if it is avoided forever (Eyer, 2009). The calculation for the single year deferral benefit is the total project cost times the fixed charge rate. Eyer (2009) also gives the range of the cost for T&D capacity installed: \$25 - \$250 per kW. In this study, we use \$150/kW as the cost of T&D installed, and we assume that the substation capacity can only be added in 10MVA increments.

The monthly peak shaving benefits mainly accrue to the municipal utilities and electric cooperatives who purchase power under a large general service rate schedule. They usually experience a high monthly demand charge rate and energy storage could be utilized to help them avoid high monthly peak charges. In this study, the Duke Energy large general services schedule LGS-50 (Duke, 2018) is used as a reference. The demand charge is \$11/kW per month. The energy cost \$55/MWh is used to estimate the operational cost of energy storage since it incurs losses for both charge and discharge.

Note that an Excel spreadsheet VBA tool has been created for the capacity deferral and peak shaving case study. The load shape profiles, system capacity limit, energy storage charge and discharge control settings, cost parameters for energy storage and the benefit value for peak shaving can be updated easily for further study.

## Reliability Enhancement

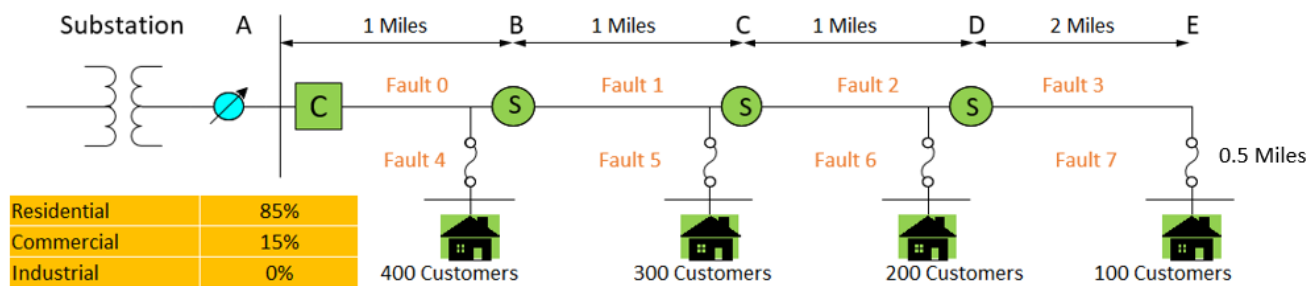
In order to evaluate the benefits of utilizing storage to improve reliability, we compare energy storage to conventional upgrade options. The conventional options involve either deploying backup generation or making line upgrades that involve converting overhead lines to underground, since underground lines usually have a lower failure rate. We also include the value of placing targeted distributed backup generation. The energy storage and backup generator are sized to achieve a similar reliability index as converting overhead lines to underground.

The hypothetical case study feeder is shown in Figure 6.2.7; the length of the backbone, lateral (0.5 mile) and number of customers are shown. It is assumed that 85% of the customers are residential and 15% are commercial. Eight possible fault locations on the backbone and lateral are analyzed. It is assumed only 1 fault happens at one time. The failure rate and repair time for overhead and underground lines are shown in Table 6.2.3. Currently, all the backbones and laterals have an overhead configuration. With the failure rate, number of customers, and feeder length, we can calculate that the projected SAIFI and SAIDI of the system is 1.855 interruptions/year per customer with 7.4 hours average outage per customer per year. We are starting with a feeder that has relatively poor reliability with high SAIFI and SAIDI values. Our goal is to improve the system reliability to the average of 2.65 hours for SAIDI and 1.37 average interruptions for SAIFI (NCSEA, 2017). The formula to calculate SAIFI and SAIDI are:

- SAIFI (System average interruption frequency index)*

$$= \frac{\text{Number of customer interruptions}}{\text{Number of customer served}} / \text{yr}$$
- SAIDI (System average interruption duration index)*

$$= \frac{\text{Sum of customer interruption durations}}{\text{Number of customer served}} / \text{yr}$$



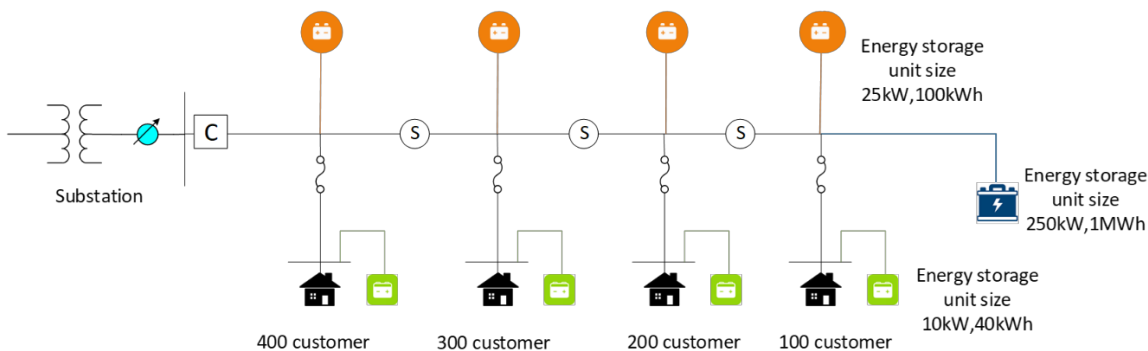
**Figure 6.2.7.** Study feeder used for the distribution reliability analysis.

**Table 6.2.3.** Failure rate and repair time

Failure Rate and Repair Time (NCSEA, 2017; NCPSUC, 2003)	
OH (Backbone/Lateral)	0.8/0.35 failures/year
UG (Backbone/Lateral)	0.2/0.17 failures/year
OH repair time:	4 hr
UG repair time:	4.5 hr

In our sample analysis, we assume three possible locations for the energy storage unit and backup generators. These include the substation, along the distribution feeder, and at the customer site (on the utility side of the meter) as shown in Figure 6.2.8. The unit size for the three locations are 100kW, 50 kW and 25kW respectively. The energy storage unit is sized and added if needed on an annual basis to achieve the desired SAIDI value, since we are considering a 1% load growth every year. The backup generator alternative is studied at the same locations with identical kW size as the energy storage. Placing smaller energy storage units near the load could provide additional value streams. However, the smaller units would have higher \$/kWh cost than larger storage units.

The cost of the four-hour lithium-ion battery in different sizes are shown in Table 6.2.4. For backup generators, the cost is assumed to be \$1000/kW for a diesel generator system at the end of the feeder (Kutz, 2014; Schienbein, 2004). Similarly, the cost for the smaller diesel units along the feeder/customers are \$1250/kW and \$1500/kW respectively. The cost of converting overhead to underground is \$450,000 per mile (NCSEA, 2017).



**Figure 6.2.8.** Study feeder for the distribution reliability study, and different potential locations for energy storage.

**Table 6.2.4.** Energy Storage Cost for Different Sizes

Class	Utility	Commercial	Residential
Cost 2019 (\$/kWh)	369	551	748
Cost 2030 (\$/kWh)	200	252	342
O&M (\$/kW-yr.)	15	83	71
Augmentation + Warranty (\$/kW-yr.) 2019	78	0	0
Augmentation + Warranty (\$/kW-yr.) 2030	35.7	0	0
Life Time (yr.)	20	10	10

The simulation is programmed using Excel spreadsheet VBA for a time frame of 10 years. The load growth rate is 1%. Hourly load profiles for typical southeast utilities are drawn from (Hoke, 2017). For every hour in a year, all the possible faults are examined to see whether it can be covered by the energy storage or backup generator. Then the number of hours that are not covered over the total hours in one year (8760 hours) is used as a factor to be applied to the calculation of number of minutes of customer outages. For the energy storage option, if it cannot support the whole outage time associated with each event, no partial credit is counted. We assume that the energy storage unit always maintains a 100% state of charge before discharging.

We consider the avoided cost of interrupted power in the benefits analysis. The cost of interrupted power for 1 hour is \$2.7 for a residential site, \$886 for a commercial site and \$3253 for an industrial (Hamachi, 2004). We assume that this feeder has 85% residential and 15% commercial customers. This would give us an average worth of \$135 per hour per customer.

Note that a spreadsheet tool has been created for the reliability analysis. All the following assumptions including feeder characteristics, customer numbers, class and distribution, failure rate, load profile, cost of energy storage/backup generator/feeder upgrade and cost of interrupted power are input info that can be easily changed to be customized for a different case study.

### **Voltage Control for High Penetrations of Solar**

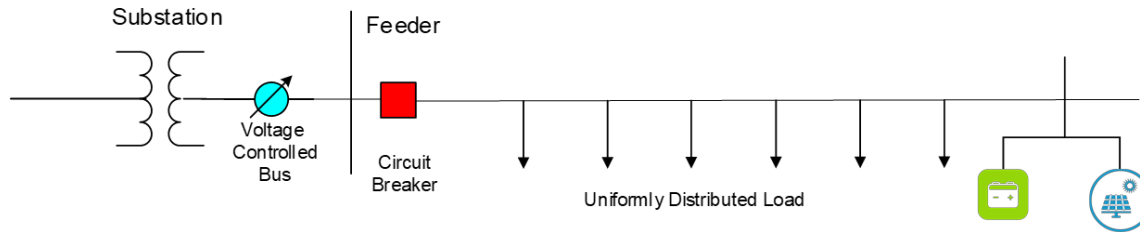
The traditional approach to mitigating overvoltage caused by distribution-level PV generation is to upgrade the distribution circuit. Upgrading the distribution line can reduce line impedance, such that the voltage increase caused by backfeeding solar PV can be reduced. Energy storage can also be used to mitigate overvoltage by charging with PV energy during those time periods when the PV is otherwise driving the voltage high.

The hypothetical case study feeder is shown in Figure 6.2.9 with uniformly distributed load. The system voltage is 23kV and percent per unit voltage at the substation is 104% of nominal. The length of the feeder is 10 miles and PV is located 7 miles away from the substation. An hourly load profile for 23 kV system and representative of southeast utilities is used (Hoke, 2017). The hourly PV irradiance data at Raleigh-Durham International airport, NC is obtained from National Solar Radiation Data Base (NSRDB) (NREL, 2005). The feeder has a peak load of 8 MW and the size for the PV system is 5 MW. The conductor assumed for the primary feeder backbone is 336 aluminum conductor steel-reinforced cable (ACSR) with impedance obtained from Gonen (2008). From there, we can calculate the voltage at the point of PV interconnection using the K factor method (Gonen, 2008). To calculate the voltage at the PV point, we need to calculate the voltage drop between the substation and PV site using the following equations:

$$VD = \frac{1}{2} \times K \times S_{3\phi} \quad (1)$$

$$K = \frac{(rcos\theta + xsin\theta)}{3V_L - n^2} \times 1000 \quad \text{unit: \%VD/kVA-mile} \quad (2)$$

$$V_{PV} = V_{sub} - VD \quad (3)$$



**Figure 6.2.9.** Energy storage location for voltage control.

In the study, hourly simulation is performed using Excel spreadsheet VBA. First, we calculate the PV hosting capacity, which means the maximum PV system size that can be added to the interconnection point without causing any overvoltage issues. Then, we increase the PV system size and mitigate the overvoltage issue using the feeder upgrade method or adding energy storage to the feeder. Energy storage is added at the same location with the PV.

The control strategy only allows energy storage to be charged with PV. There is a monthly voltage threshold setting for the energy storage, if the point of interconnection voltage is higher than the threshold, the energy storage will be charged if there is any capacity left. The discharge of energy storage is set to occur around the monthly peak hours. There is also a monthly time setting to decide when the energy storage should discharge, and it is set to occur during the monthly peak hours to give additional peak shaving benefit.

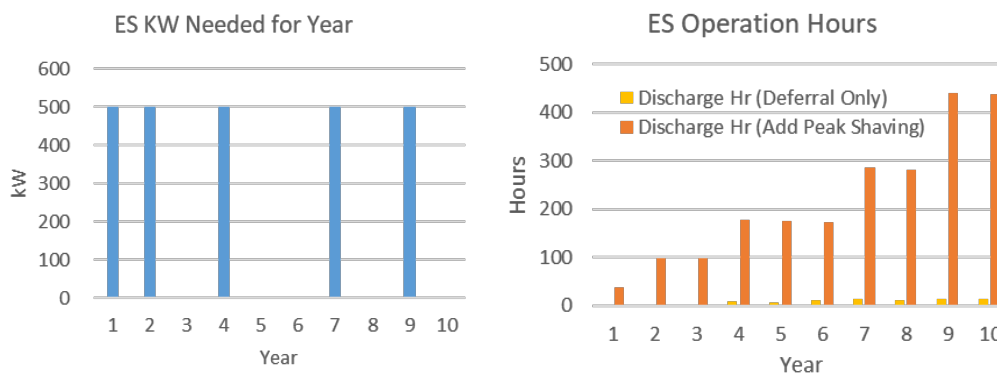
The cost of upgrading to a larger wire size is assumed to be \$200,000 per mile (EIA, 2012). The minimum miles of conductor that need to be upgraded is evaluated in the simulation. The fixed charge rate used is 11% (10% discount rate over 25 years). The energy storage costs are shown in Table 6.2.2. The benefit for peak shaving is evaluated at \$11/kW (Duke, 2018). Since energy storage incurs losses in both charge and discharge, this part of the loss is treated as operating cost, which is monetized at \$55/MWh (Duke, 2018).

Note that we assume a 0% load growth rate is the worst case. The heavier loading condition will alleviate the PV overvoltage issue by contributing to the voltage drop. As long as the energy storage unit can support the designed PV system for the first year, it will continue to work in later years if the loads keep growing.

### 6.2.3 Results of Benefit-Cost Analysis

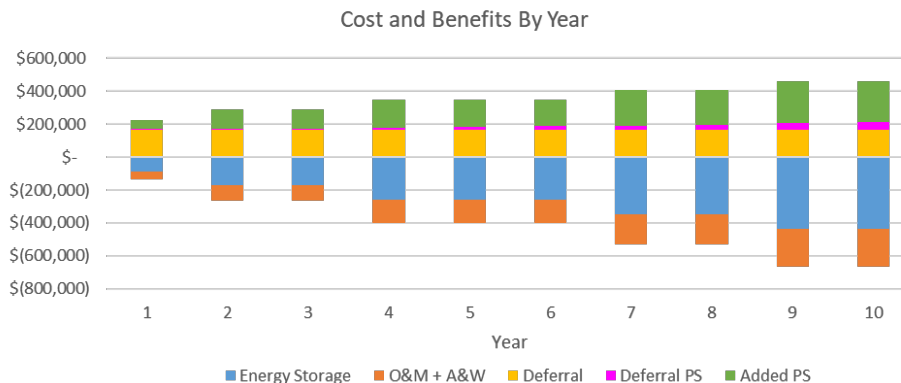
#### Capacity Deferral and Peak Shaving

The resulting kW size of energy storage that needs to be added during the ten-year timeframe for capacity upgrade deferral is shown in Figure 6.2.10. Since we are assuming a 1% load increase and the energy storage (ES) can be added in 500 kW units, we need to add an energy storage unit in Years 1, 2, 4, 7 and 9. Figure 6.2.10 also shows the discharge hours for each year. It can be seen from the figure that if energy storage is only used for deferral, it is very under-utilized, operating only a couple of times per year. Together with the peak shaving, the energy storage is better utilized. Also, the more storage capacity is added, the more value it has for peak shaving.



**Figure 6.2.10.** Energy storage needs (left) and storage utilization for capacity deferral and peak shaving (right).

The benefit-cost results by year are shown in Figure 6.2.11. It can be seen that the deferral benefits (shown in yellow) dominate the total benefits during the initial years and remain constant. However, as the available storage capacity gets larger, more peak shaving benefits are obtained, as shown in green. The additional peak shaving benefits represent the demand charge that the cooperatives and municipal utilities could avoid, and is calculated based on the Duke LGS-50 rate. If the tariff is designed correctly to capture the peak capacity deferral at the system level, then this part of the benefit should align with the system level capacity deferral benefit. The O&M and augmentation plus warranty (A&W) cost is increasing as the installed energy storage capacity increases over time.



**Figure 6.2.11.** Benefits and costs over time associated with using storage on the distribution network for capacity deferral and peak shaving.

The annualized benefit-cost analysis per kW for both 2019 and 2030 are shown in Table 6.2.5. The benefits include the deferral benefits, peak shaving associated with capacity deferral, and additional optimal peak shaving control benefits. It can be seen from the table that at year 2019, the net benefit is -17 \$/kWyr. However, in year 2030, the net benefit becomes \$53/kWyr. In 2030, the break-even capital cost for the 4-hour Li-ion battery in this application is 305 \$/kWh.

**Table 6.2.5** Capacity Deferral/Peak Shaving Cost Benefit Results (2019 and 2030)

<b>Benefit-Cost Analysis</b>	<b>Units: \$/kWyr</b>
<b>Benefit</b>	<b>136</b>
- Deferral	66
- Deferral Peak Shaving	7
- Added Peak Shaving	62
<b>Cost (2019)</b>	<b>153</b>
<b>Net (2019)</b>	<b>-17</b>
<b>Cost (2030)</b>	<b>83</b>
<b>Net (2030)</b>	<b>53</b>

### **Reliability Enhancement**

In this study, we are comparing the use of energy storage versus converting overhead (OH) to underground (UG) feeders as well as deploying backup generators. Similarly, we are assuming a 1% load growth during the ten-year analysis. Energy storage or a backup generator is added each year to achieve the reliability target. The results for converting OH to UG is shown in Table 6.2.6. Converting only the main feeder backbone conductors yields the highest NPV. For this case, the resulting SAIDI is 2.6 hours/year and SAIFI at 0.595 interruptions/year.

**Table 6.2.6.** Reliability study results – Converting OH to UG

OH to UG	ALL	Backbone	Lateral
SAIFI	0.505	0.595	1.765
SAIDI	2.3 hr.	2.6 hr.	7.1 hr.
Annual Cost	\$347K	\$248K	\$99K
Annual Benefits	\$696K	\$653K	\$43K
NPV	\$2.14M	\$2.49M	\$(345K)

The results for energy storage sizing and benefit-cost analysis are shown in Tables 6.2.7 and 6.2.8. Adding energy storage brings the SAIDI down to an average of 2.5 hours for the 10 year period. However, it will not help with the SAIFI index, which means the number of interruptions that customers are going to face will not be changed. In both the 2019 and 2030 case, the end of the feeder application has the highest NPV since the cost for energy storage along the feeder and at the customer site are higher in the study. Although the greatest annual benefit is obtained when energy storage is placed near customer locations, the benefits do not offset the extra cost assumed in the study. For the 2019 case, the energy storage case has a negative NPV. However, for the 2030 case, the NPV becomes positive and outweighs the feeder upgrading case. The annual cost, benefit, and net values in \$/kWyr are also calculated for comparison between the different cases. The break-even capital cost for energy storage is 366\$/kWh, 272\$/kWh and 304\$/kWh for three locations respectively.

**Table 6.2.7.** Reliability Study Energy Storage Added

Year	End Feeder (kW)	Along Feeder (kW)	Customer (kW)
Year 1	2500	2500	2500
Year 2			
Year 3			
Year 4			
Year 5		50	
Year 6			
Year 7	100	50	
Year 8			25
Year 9		50	25
Year 10			25

**Table 6.2.8.** Reliability study energy storage benefit-cost results (2019 and 2030)

	Energy Storage (2019)			Energy Storage (2030)		
	End Feeder	Along Feeder	Customer	End Feeder	Along Feeder	Customer
SAIFI	1.855	1.855	1.855	1.855	1.855	1.855
Average SAIDI	2.5 hr.	2.5 hr.	2.5 hr.	2.5 hr.	2.5 hr.	2.5 hr.
Annual Cost	674K	1.12M	1.4M	366K	629K	737K
Annual Benefit	671K	662K	675K	671K	662K	675K
NPV	-17K	-2.8M	-4.5M	1.9M	205K	-379K
Annual Net	-2.77K	-462K	-725K	305K	33K	-61K



Cost \$/kWyr	259	424	544	141	237	286
Benefit \$/kWyr	258	250	262	258	250	262
Net \$/kWyr	(1)	(174)	(282)	117	13	(24)

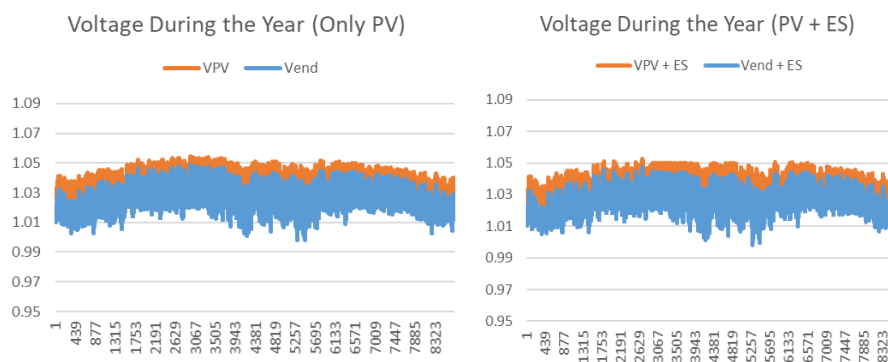
The benefit-cost analysis results for deploying backup generators is shown in Table 6.2.9. The most cost-effective option is to place the backup generation at the end of the feeder. The NPV value is slightly better but very close to the feeder upgrade case. The energy storage 2019 case is more expensive than the backup generator case. However, energy storage becomes more cost-effective than the backup generator case when assuming 2030 Li-ion battery costs.

**Table 6.2.9.** Reliability study results – backup generator

	End Feeder	Backup Generator Along Feeder	Customer
SAIFI	1.855	1.855	1.855
Average SAIDI	2.5 hr.	2.5 hr.	2.5 hr.
Annual Cost	419K	518K	613K
Annual Benefit	671K	662K	675K
NPV	1.55M	887K	385K
Annual Net	252K	144K	63K
Cost \$/kWyr	161	195	238
Benefit \$/kWyr	258	250	262
Net \$/kWyr	97	54	24

### Voltage Control for High Penetrations of Solar

In this part of the hypothetical case study, a 5 MW PV system is added 7 miles away from the substation. The voltage at the point of interconnection during the year is shown in Figure 6.2.12. The voltage is over 105% percentage per unit compared to nominal for 112 hours during the year. In this analysis, we reduce the size of the PV to determine the hosting capacity at this location. When the size is 4 MW, there is no overvoltage issue during the year. So 4 MW is the hosting capacity. The benefit difference between the 5 MW and 4 MW is captured as the value for enabling a higher PV penetration on the feeder.



**Figure 6.2.12.** Voltage at point of PV interconnection for a year with and without energy storage.

The simulation shows that at least 1200 kW of battery capacity is needed to mitigate the overvoltage issue of the 5 MW PV system, as shown in Figure 6.2.12. Also, the overvoltage issue can be fixed by upgrading at least 5 miles of backbone feeder from 336 ACSR to 477 AAC conductor. The results of the benefit-cost analysis is shown in Table 6.2.10. There is no break-even capital cost; even when the cost of energy storage is \$0/kWh, the benefits cannot be offset by the annual O&M, augmentation, and warranty costs.

**Table 6.2.10.** Voltage Control and PV integration Study Results

<b>Comparison</b>	<b>Energy Storage</b>	<b>Upgrade</b>
Annual Cost (2019)	319,000	110,000
Annual Peak Shaving Benefit	28,000	13,000
Annual PV Energy Added	81,000	87,000
Net (2019)	-210,000	-21,000
Annual Cost (2030)	174,000	-
Net (2030)	-65,000	-
Benefit (\$/kWyr)	91	-
Cost (\$/kWyr)(2019)	266	-
Net (\$/kWyr)(2019)	-175	-
Cost (\$/kWyr)(2030)	145	-
Net (\$/kWyr)(2030)	-54	-

### 6.2.5 Conclusions from the Distribution Study

Price declines by 2030 are expected to make the use of Li-ion batteries to provide peak capacity deferral and peak shaving at the substation as well as reliability enhancement attractive applications in the future. Under the assumptions used in our analysis, the voltage control scenario was not cost-effective in either 2019 or 2030. The distribution circuits tested here are hypothetical, and the conditions associated with distribution circuits across the state vary widely. Some of the poorest performing distribution circuits likely present near-term opportunities for storage deployment. For example, Duke Energy is planning a microgrid project, including a 4 MW Li-ion battery, in the Hot Springs community in order to defer ongoing maintenance of an existing distribution power line that serves the remote town (Lillian, 2018).

The Massachusetts (MDER, 2016), New York (NYSERDA, 2018) and Nevada (Hledik, 2018) studies analyze the value of energy storage for utility distribution systems. However, in all three studies, transmission and distribution benefits are lumped together, which makes it difficult to compare the results to our study, which are distribution-focused only.

## References

- Anderson Hoke, Randomized Hourly Load Data for use with Taxonomy Distribution Feeders, August 2017. <https://catalog.data.gov/dataset/randomized-hourly-load-data-for-use-with-taxonomy-distribution-feeders>
- Jim Eyer, Electric Utility Transmission and Distribution Upgrade Deferral Benefits from Modular Electricity Storage, SAND2009-4070, Sandia National Laboratories, June 2009. <https://prod.sandia.gov/techlib-noauth/access-control.cgi/2009/094070.pdf>
- Duke, 2018, Large General Services Schedule LGS-50, <https://www.duke-energy.com/ /media/pdfs/for-your-home/rates/electric-nc/g9ncschedulelgsdep.pdf?la=en>
- NCSEA, “Direct Testimony of Caroline Golin on Behalf of the North Carolina Sustainable Energy Association” North Carolina Sustainable Energy Association (NCSEA), November 2017. [https://votesolar.org/files/2215/1741/2799/Direct\\_Testimony\\_of\\_Caroline\\_Golin\\_2.pdf](https://votesolar.org/files/2215/1741/2799/Direct_Testimony_of_Caroline_Golin_2.pdf)
- NCPSUC, Report of the public staff to the North Carolina natural disaster preparedness task force: The feasibility of placing electric distribution facilities underground, North Carolina Public Staff Utilities Commission (NCPSUC), November 2003. <https://www.ncuc.net/reports/undergroundreport.pdf>
- J.kutz, G. Saur, S. Sprik and C. Ainscough, Backup Power Cost of Ownership Analysis and Incumbent Technology Comparison, NREL, September 2014. <https://www.nrel.gov/docs/fy14osti/60732.pdf>
- L. Schienbein, P. Balducci, T. Nguyen, D. Brown, J. DeSteele, G. Speer, Avoiding Distribution System Upgrade Costs Using Distributed Generation, PNNL, Jan. 2004 [http://northwestchptap.org/NwChpDocs/Avoiding\\_elec\\_distrib\\_costs\\_by\\_DG\\_PNNL\\_study.pdf](http://northwestchptap.org/NwChpDocs/Avoiding_elec_distrib_costs_by_DG_PNNL_study.pdf)
- K. Hamachi LaCommare and J. H. Eto, Understanding the Cost of Power Interruptions to U.S. Electricity Consumers, LBNL, 2004. <https://emp.lbl.gov/sites/all/files/lbnl-55718.pdf>
- Turan Gonen, Electric Power Distribution System Engineering, 2<sup>nd</sup> Edition, 2008, CRC Press
- NREL, National Solar Radiation Data Base (NSRDB), 1991-2005 Typical Meteorological Year 3. [https://rredc.nrel.gov/solar/old\\_data/nsrdb/1991-2005/tmy3/](https://rredc.nrel.gov/solar/old_data/nsrdb/1991-2005/tmy3/)
- EIA, Cost-per-mile (range and average) for distribution power lines, July 2012 <https://www.eia.gov/todayinenergy/detail.php?id=7250>
- New York State Energy Research and Development Authority (NYSERDA). (2018). *New York State Energy Storage Roadmap*. Online at: <https://www.nyserd.ny.gov/All%20Programs/Programs/Energy%20Storage/Achieving%20NY%20Energy%20Goals/The%20New%20York%20State%20Energy%20Storage%20Roadmap>
- Massachusetts Department of Energy Resources (MDER), Massachusetts Clean Energy Center, Customized Energy Solutions, Sustainable Energy Advantage, Daymark, Alevo Analytics (2016). State of Charge: Massachusetts Energy Storage Initiative. [http://energystorage.org/system/files/attachments/ma\\_storage\\_study.final\\_w5768299x7ac2e.pdf](http://energystorage.org/system/files/attachments/ma_storage_study.final_w5768299x7ac2e.pdf)

Hledik R, Chang J, Lueken R, Pfeifenberger J, Pedtke JI, Vollen J (2018). The Economic Potential for Energy Storage in Nevada. Report prepared for the Public Utilities Commission of Nevada, Nevada Governor's Office of Energy. The Brattle Group. Cambridge, MA.

Lillian, B. (2018). Duke Energy Investing \$500M In Carolinas Battery Storage. *Solar Industry*, October 10, 2018. <https://solarindustrymag.com/duke-energy-investing-500m-in-carolinas-battery-storage/>

### 6.3. Transmission Congestion Relief

Grid congestion can drive disparities in the cost of serving an additional unit of load (i.e., the marginal load) across regions within a given service area. For example, assume a service area could generically be subdivided into eastern and western portions and that low marginal cost generators were primarily located in the western portion. If load increases in the eastern portion of a service area when the transmission grid is congested, that load would have to be met by the more expensive eastern generating sources, even if there is idle capacity in the relatively cheaper western generators. This cost disparity could be alleviated by reducing congestion through transmission expansion. Storage located in congested areas can also reduce the cost disparity, charging during uncongested hours, and dispatching electricity during congested hours.

To determine the scope for storage to alleviate congestion-related issues, we must first establish the degree of grid congestion in North Carolina. With a complete power flow model, one could easily ascertain the level of grid congestion, however such a model was not available to us. As a proxy for possible congestion frequency, we explore the frequency of non-economic dispatch (i.e., high marginal cost generators running during times when lower cost generators could be running) in the North Carolina service territories.

#### 6.3.1 Data Acquisition and Processing

For this analysis, we use publicly available data from EPA Air Markets Program (U.S. EPA, 2018), FERC Form 1 filings (FERC, 2018), EIA Form 923 data (EIA, 2018, “Form 923”), and EIA Form 860 data (EIA, 2018, “Form 860”) to acquire information on all plants and generators in Duke Energy’s balancing authority. The data was processed to aggregate units to plant level by prime mover (i.e., combustion turbine (CT), combined cycle (CC), and steam turbine (ST)) by fuel type. All of the collected and calculated generator plant-level data is shown in Table 6.2.1. Note some of the generators can use two forms of fuel. They are listed once for each primary fuel in Table 6.2.1 but are not used to determine the marginal generator in this analysis.

For each fossil-fuel plant, we calculate the variable operations and maintenance (VOM) costs, variable fuel costs, and marginal costs and collect the heat rate, winter and summer capacity, and hourly generation. VOM costs are calculated from the FERC Form 1 filings for 2017 which are plant owners’ reported plant statistics including costs, fuel usage, and production. The annual non-fuel VOM costs are calculated as the sum of steam and electric expenses as well as allowances. Dividing total costs by the net generation for that year yields the VOM cost on a per MWh basis for non-fuel costs. To get the fuel cost, we multiply the plant’s heat rate (MMBtu of fuel burned per MWh of production) by a corresponding fuel price. The heat rate for each plant is taken from FERC Form 1. We use annual average fuel prices from the EIA “Electric Power Annual” for fuel delivered to electric utilities in NC. The marginal cost (MC) of the plant is then simply the sum of the VOM and fuel costs.

For other non-fossil-fuel plants, notably PV and nuclear plants, which are not generally reported in the EPA Air Markets Program data, we reasonably assume that they have marginal costs below that of the fossil-fuel plants and are always dispatched when available. Thus, we only consider the non-economic dispatch of fossil fuel plants.

There were also some complications in determining the MC for certain plants. Specifically, the Smith Energy Complex’s VOM and heat could not be determined separately for the CT and CC components directly from the FERC 1 forms because both prime movers’ costs and heat rates were reported together. To estimate the MC of each prime mover separately, we use the capacity for each component of the CC and CT plants from the EIA Form 860. EIA Form 860 reports the capacity of individual generating units, including which CTs operate as part of a CC unit and which CTs are not part of a CC unit. The variable expenses from FERC Form 1 for the plant are allocated proportionally to the capacity of each prime mover. The VOM cost per MWh is calculated based on the annual generation from EIA Form 923 by prime mover as well.

For determining whether a generator was committed, we use the generation and emissions data from the EPA Air Market Program for 2016 and 2017. For natural gas generators and most coal generators (all over 25 MW in capacity), the EPA reports hourly electricity generation as well as emissions. For thermal generators with reported energy production, we consider a plant that had net-positive generation to be committed at a given hour. For some steam plants, the generation is not reported for all hours. For these plants, we use the operating time to determine if the plant is committed during a given hour (i.e., committed when operating time for an hour is positive). The lack of generation data for many steam plants limits our ability to estimate the capacity factor but does indicate its commitment status at a given hour.

From the calculations of marginal cost and collection of plant capacities in Table 6.2.1, we created a supply curve (shown in Figure 6.2.1). This supply curve shows the merit order of fossil-fuel plants for economic dispatch when all plants are available to supply electricity across the balancing area (i.e., all generators are available to dispatch and no congestion or reliability issues are present). We use this merit order to determine when non-economic dispatch is occurring.

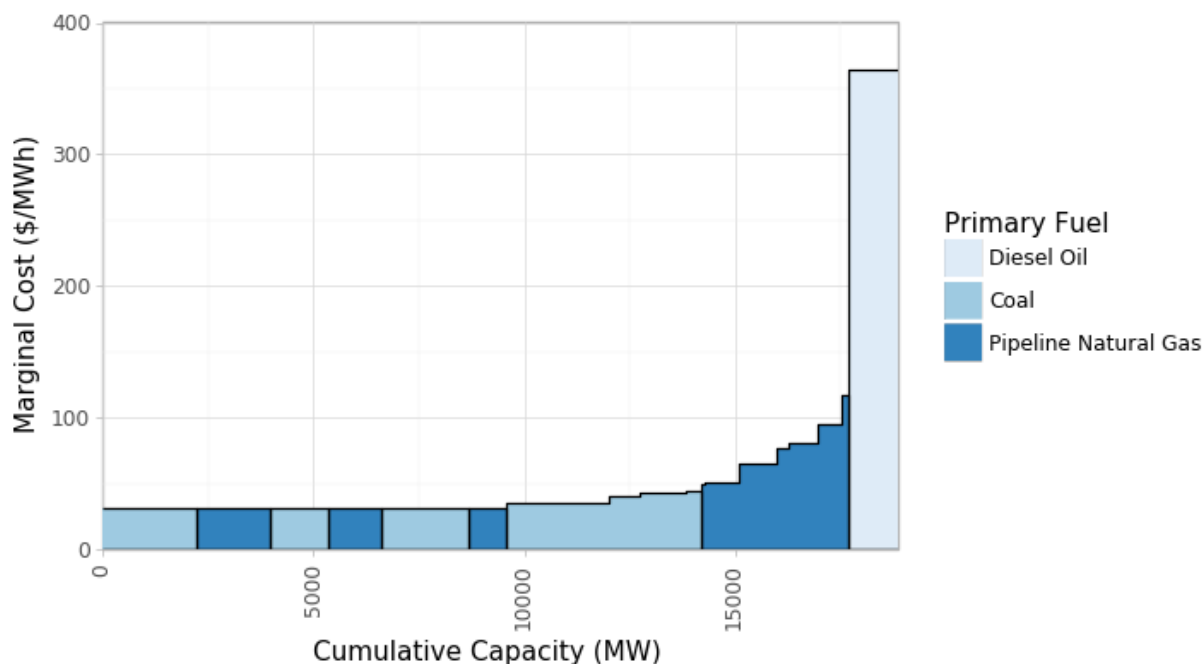


Figure 6.3.1. Supply curve of fossil-fuel plant based on estimated marginal costs.

**Table 6.3.1.** Generator attributes and calculated parameters

ID	Plant Name	Plant Type	Primary Fuel	Heat Rate (MMBtu/ kWh)	VOM Cost (\$/MWh)	fUEL Variable Cost (\$/MWh)	Marginal Cost (\$/MWh)	Sumer Capacity (MW)	Winter Capacity (MW)
<b>Alle.ST</b>	G G Allen	ST	Coal	11,047	9.18	34.08	43.27	1,098	1,130
<b>Ashe.CT</b>	Asheville	CT	Natural Gas	12,226	23.87	53.30	77.18	320	370
<b>Ashe.ST</b>	Asheville	ST	Coal	11,932	8.16	36.81	44.97	378	384
<b>Bele.ST</b>	Belews Creek	ST	Coal	9,167	2.59	28.28	30.87	2,220	2,220
<b>Buck.CC</b>	Buck	CC	Natural Gas	7,063	0.36	30.79	31.15	668	716
<b>Clif.ST</b>	Cliffside	ST	Coal	9,058	3.40	27.94	31.34	1,388	1,390
<b>Dan.CC</b>	Dan River	CC	Natural Gas	7,137	0.47	31.11	31.58	662	718
<b>Darl.CT</b>	Darlington County	CT	Diesel Oil	14,715	16.66	145.09	161.75	664	846
<b>Darl.CT</b>	Darlington County	CT	Natural Gas	14,715	16.66	64.15	80.81	664	846
<b>HFL.CC</b>	H F Lee Steam Electric Plant	CC	Natural Gas	7,229	0.47	31.52	31.98	888	1059
<b>HFL.CT</b>	H F Lee Steam Electric Plant	CT	Diesel Oil	11,834	13.38	118.78	132.16	857	963
<b>HFL.CT</b>	H F Lee Steam Electric Plant	CT	Natural Gas	11,834	13.38	51.59	64.98	857	963
<b>Linc.CT</b>	Lincoln	CT	Diesel Oil	19,565	167.82	196.37	364.19	1,193	1,565
<b>Mars.ST</b>	Marshall	ST	Coal	9,495	2.50	29.29	31.79	2,058	2,078
<b>Mayo.ST</b>	Mayo	ST	Coal	11,513	4.38	35.52	39.90	727	746
<b>Mill.CT</b>	Mill Creek Combustion Turbine	CT	Natural Gas	14,072	33.26	61.35	94.61	563	735
<b>Rock.CT</b>	Rockingham County CT	CT	Natural Gas	11,055	2.64	48.20	50.84	825	895
<b>Rox.ST</b>	Roxboro	ST	Coal	10,552	3.06	32.55	35.61	2,439	2,462
<b>Smit.CC</b>	Richmond County Plant	CC	Natural Gas	7,702	0.54	33.58	34.12	1,073	1,231
<b>Sutt.CC</b>	L V Sutton	CC	Natural Gas	7,133	0.58	31.10	31.67	607	719
<b>WSL.CT</b>	W S Lee	CT	Natural Gas	10,408	3.74	45.38	49.12	84	96
<b>WSL.ST</b>	W S Lee	ST	Natural Gas	14,688	53.60	64.03	117.64	170	173

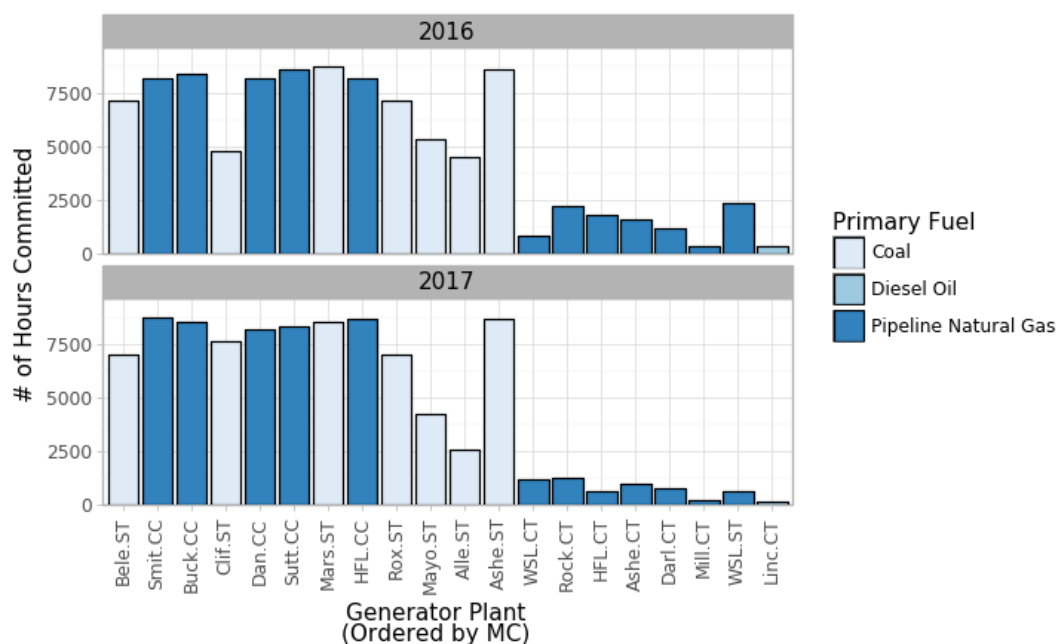
### 6.3.2 Methods

For each hour of 2016 and 2017, we determine which plants were committed based on whether they have non-zero generation and which plant is the marginal generator (i.e., the plant operating that hour with the highest marginal cost). We then note an incidence of out-of-merit-order dispatch (non-economic dispatched) when we observe plants that are uncommitted while having a lower variable cost than the marginal generator.

As noted above, this non-economic dispatch may be, but is not necessarily, a signal of grid congestion. This is a very conservative specification of non-economic dispatch, as we do not consider incidences where lower marginal cost plants are running at partial capacity while higher marginal cost plants are simultaneously being dispatched. Additionally, we are not able to differentiate exactly whether thermal generators are operating out of merit order due to congestion or some other outage (e.g. planned maintenance or forced outage) or reliability event. To minimize the likelihood that we are only examining non-economic dispatch due to plant closures for maintenance, we also run the analysis only over months during which NC has high demand (i.e., January, February, July, and August). Since more plants are needed to supply load during high demand months, plants will not be offline for long-term planned outages.

### 6.3.3 Results

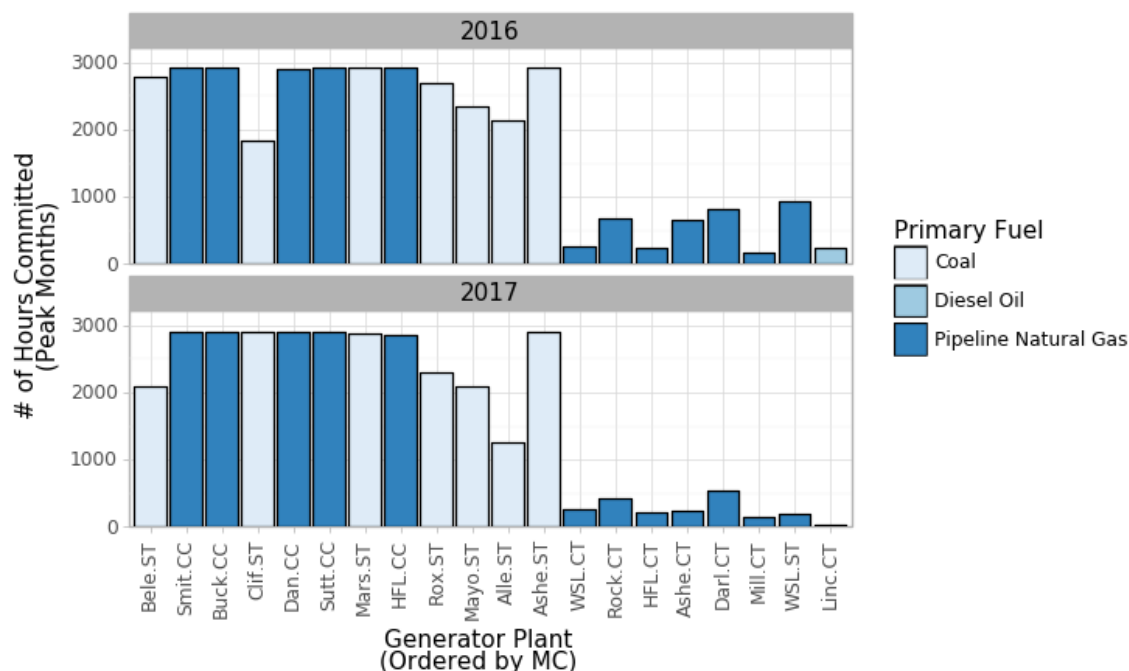
Figure 6.2.2 shows the number of hours in each year that a generator is committed. In general, lower MC generators are committed more frequently while high cost generators are run much less frequently, as expected. The biggest difference is that the Asheville ST operates almost every hour of the year, while coal-fired plants with lower MC in other areas of the state (Roxboro, Mayo, and Allen) operate much less frequently. This difference in operation frequency suggests that there are non-economic reasons for the plants to be uncommitted, which could be due to congestion.



**Figure 6.3.2.** Number of hours that a generator is committed (i.e., generating electricity) during 2016 and 2017. Generators are ordered from lowest to highest MC (left to right).

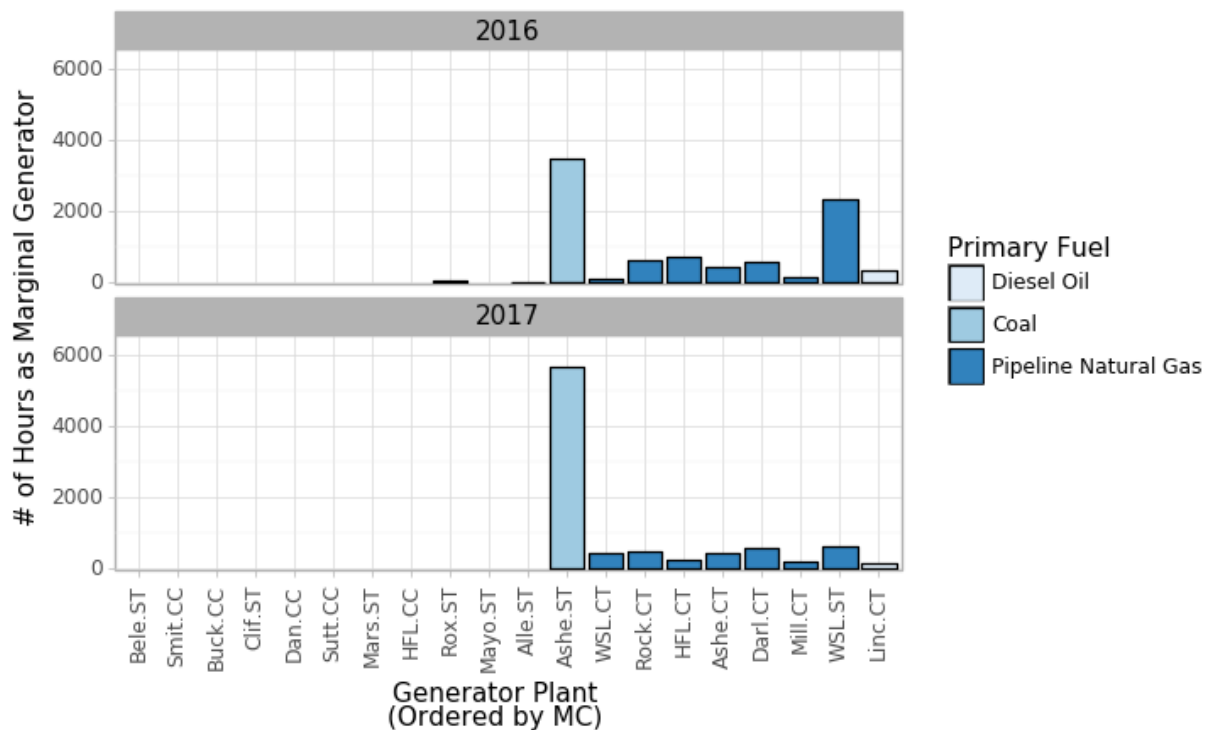


Figure 6.2.3 shows frequency with which each generator was committed during months with high electricity demand (January, February, July, and August). The frequency pattern associated with these plants is similar for the full year and over high demand months. Since we can safely assume that these plants will not be offline for long periods of scheduled maintenance during the high demand months, the difference dispatch is more likely due to congestion than outages.



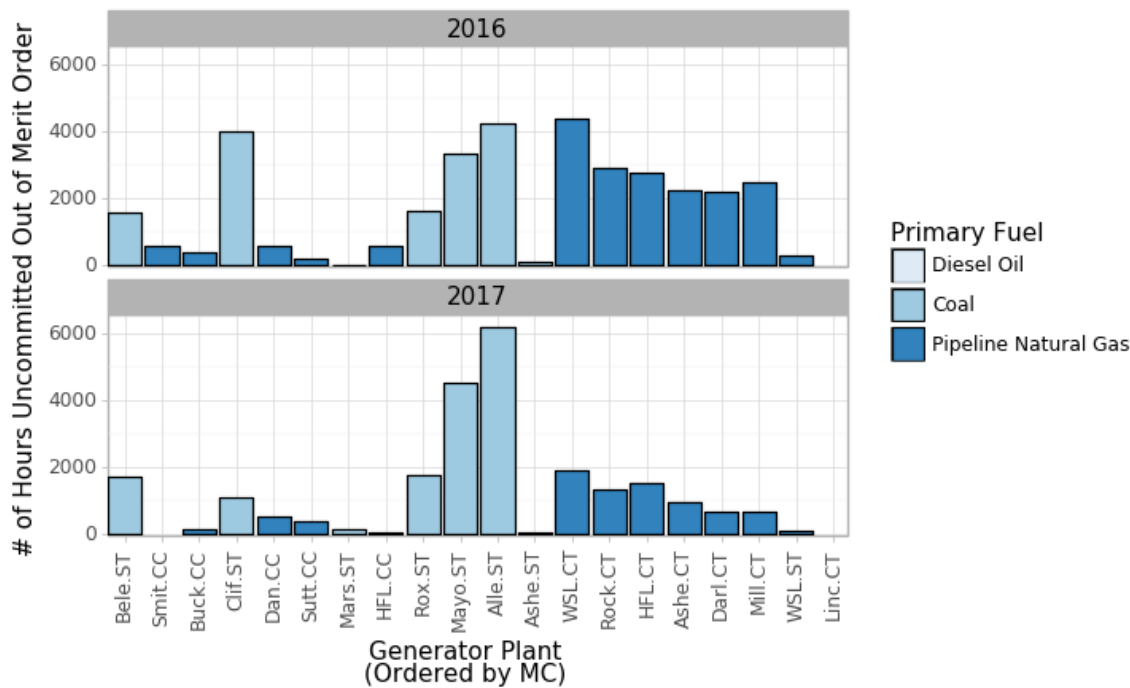
**Figure 6.3.3.** Number of hours that a generator is committed (i.e., generating electricity) during 2016 and 2017 peak electricity consumption months (January, February, July, and August). Generators are ordered from lowest to highest MC (left to right).

After comparing which generators are committed at every hour of 2016 and 2017, we determine which generator is the marginal unit (i.e., the highest MC generator operating during an hour). Figure 6.3.4 displays the number of hours a given plant is the marginal plant. The Asheville plant is most frequently the marginal generator. Since the Asheville ST operates most of the time, no generator with a lower MC is ever the marginal generator. Since some of those generators operate significantly less often than the Asheville plant, this plant is being non-economically dispatched, assuming the other plants are not experiencing an outage.

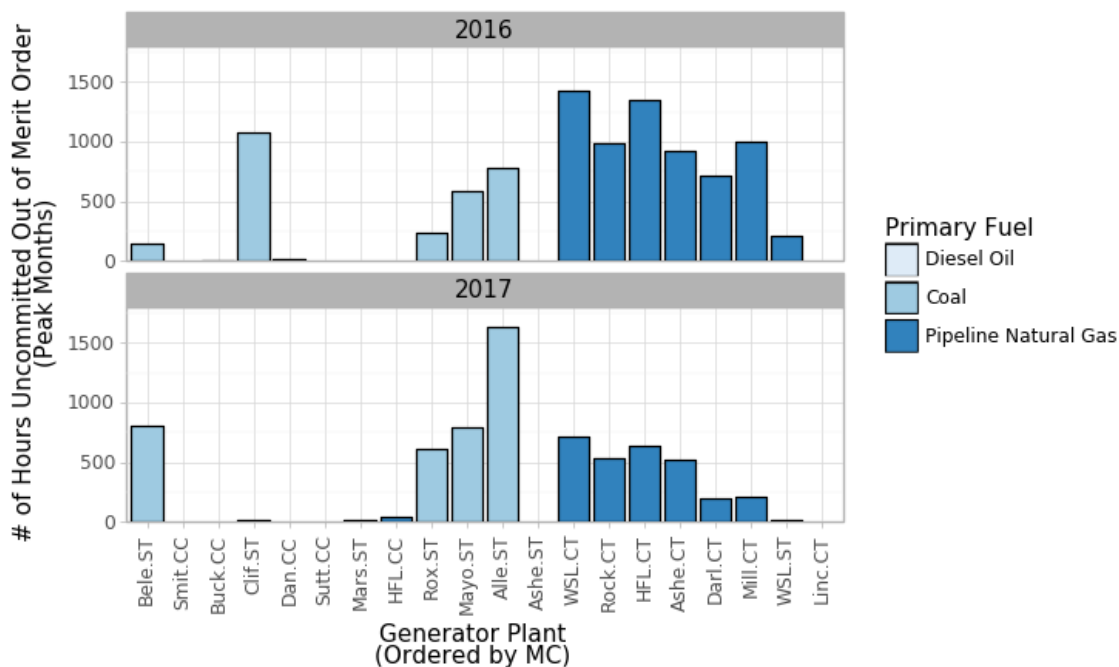


**Figure 6.3.4.** Number of hours that a generator is the marginal generator (i.e., high MC committed during an hour) during 2016 and 2017. Generators are listed in order from lowest to highest MC (left to right).

Based on the marginal generator at each hour, we determine which plants are uncommitted out of merit order for each hour. Figure 6.3.5 depicts the frequency that each plant is uncommitted out of merit order. The other coal-fired plants are often uncommitted while Asheville ST is operating. This frequency that would indicate that congestion or other related reliability issue limits the amount of generation outside of the Asheville area which can supply load near Asheville for a large portion of the year. Figure 6.3.6 shows the frequency that each plant is uncommitted out of merit order during peak electricity consumption months. For Roxboro, Allen, and Mayo STs, the frequency that they are uncommitted out of merit order appears similar to those occurrences for the rest of the year.

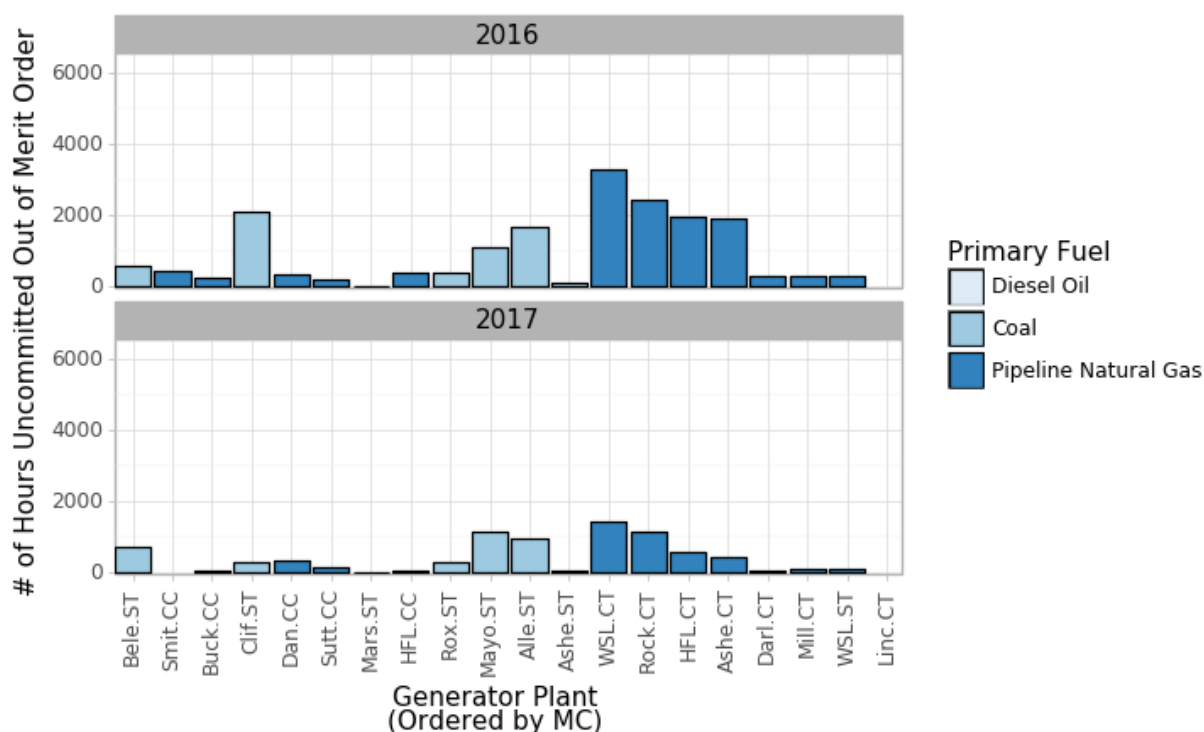


**Figure 6.3.5.** Number of hours that a generator is out of merit order (i.e., a generator is offline and a generator with a larger MC is committed) during 2016 and 2017. Generators are listed in order from lowest to highest MC (left to right).



**Figure 6.3.6.** Number of hours that a generator is the out of merit order (i.e., a generator is offline and a generator with an MC greater is committed) during peak electricity consumption months (January, February, July, and August). Generators are listed in order from lowest to highest MC (left to right).

We recognize that our estimates of marginal costs are not exact and may not correctly represent the order of the MC of plants. To examine the sensitivity of these assumptions, we calculated the number of hours a generator is uncommitted out of merit order, assuming we did not consider that generator to be out of merit order if its MC was within 50% of the MC of the marginal generator. The number of hours that plants are uncommitted and out of merit order with this condition are shown in Figure 6.3.7. The most significant difference with this assumption is that the G. G. Allen ST, Mayo, and Roxboro plants are no longer considered uncommitted out of merit order when Asheville ST is operating. Otherwise, this assumption does not make a significant difference in how often generators are uncommitted out of merit order. This result would indicate that these STs are still often uncommitted out of order even with higher MC generators than the Asheville ST.



**Figure 6.3.7.** Number of hours that a generator is out of merit order, ignoring units which have MC within 50% of the marginal generator during 2016 and 2017. Generators are listed in order from lowest to highest MC (left to right).

The frequency with which plants are uncommitted out of merit order in this analysis appears high. While some may be caused by outages or other generator issues, some of the lower cost generators are still frequently not operating (> 1,000 hours of the year) when higher cost generators are operating.

### 6.3.4 Conclusions

This analysis gives some evidence that non-economic dispatch in North Carolina occurs somewhat frequently. Congestion with limited import of electricity to the Asheville area is a possible explanation for the non-economic dispatch. In particular, congestion would explain why Mayo ST,

which has similar characteristics to the Asheville plant but lower VOM and heat rate, operates much less frequently than the Asheville ST. More analysis is needed, ideally with comparisons to power flow simulations to confirm transmission congestion causes the non-economic dispatch. If so, energy storage might be able to lower the reliance on generators in congested regions. Without these studies, we cannot accurately estimate the value that energy storage could provide or even the additional cost that operating with congestion incurs.

Qualitatively, if the NC electrical system has congestion, energy storage could provide benefits by allowing less expensive generators to operate more frequently and reduce thermal loading of transmission lines. In the current system, enabling less expensive plants located outside of congested regions to operate might lead to the existing plants operating more. However, reducing congestion also allows the siting of new, more efficient thermal plants or renewable generation in a wider area of the state. This effect on new generation has value in system planning to avoid new transmission or limits on new generator types. Reducing the thermal load on transmission can also increase the lifetime of transmission lines and reduce need for transmission line maintenance, as noted in other energy storage studies (Massachusetts, 2016; Stanfield, 2017; Vermont, 2017; Byrne, 2012).

In a congested system, energy storage can add value by reducing transmission congestion, but more studies are needed with transmission data to evaluate how the applicability and value of energy storage to the NC electrical system.

## References

- U.S. EPA. 2018 “Air Markets Data.” <https://ampd.epa.gov/ampd/>. Accessed on 17 October 2018.
- U.S. EIA. 2018 “Form EIA-923 detailed data with previous form data (EIA-906/920).” <https://www.eia.gov/electricity/data/eia923/> Accessed 28 October 2018.
- U.S. EIA. 2018 “Form EIA-860 Annual Electric Generator Report.” <https://www.eia.gov/Survey/#eia-860> Accessed 28 October 2018.
- U.S. EIA. 2018 “Electric Power Annual.” <https://www.eia.gov/electricity/annual/> Accessed 28 October 2018.
- Federal Energy Regulatory Commission. 2018. “Form 1 - Electric Utility Annual Report.” <https://www.ferc.gov/docs-filing/forms/form-1/viewer-instruct.asp>. Accessed 28 October 2018.
- Massachusetts Department of Energy Resources; Massachusetts Clean Energy Center. “State of Charge: Massachusetts Energy Storage Initiative.” Massachusetts Department of Energy Resources; Massachusetts Clean Energy Center, 2016. <https://www.mass.gov/service-details/energy-storage-study>.
- Vermont Dept. of Public Service. “Vermont Energy Storage Study,” 15 November, 2017. [http://publicservice.vermont.gov/sites/dps/files/documents/Pubs\\_Plans\\_Reports/Energy\\_Storage\\_Report/Storage\\_Report\\_Final.pdf](http://publicservice.vermont.gov/sites/dps/files/documents/Pubs_Plans_Reports/Energy_Storage_Report/Storage_Report_Final.pdf).
- Byrne, Raymond H., Matthew K. Donnelly, Verne W. Loose, and Daniel J. Trudnowski. “Methodology to Determine the Technical Performance and Value Proposition for Grid-Scale Energy Storage Systems.” Sandia National Laboratories, December 2012. <http://www.sandia.gov/ess/publications/SAND2012-10639.pdf>.

## 6.4. Transmission Investment Deferral

While not currently included in transmission investment decisions, energy storage systems can be an alternative investment to transmission projects. Currently, generation, transmission, and reactive power devices can be used to meet transmission reliability standards, but energy storage is also a viable option. In this section, we examine and categorize the currently proposed transmission projects to place an upper bound on the amount of energy storage that can be used to defer or avoid transmission investments. This review provides an indication of the possibilities; we do not have access to the models and data required to perform targeted quantitative analysis to derive net benefit estimates for particular transmission deferral projects in particular locations.

The majority of transmission expansion or upgrade projects are built to ensure compliance with NERC TPL-001-4 transmission planning standards (NERC, 2014). Transmission operators adhere to the TPL-001-4 standards, which state the allowed responses to various contingencies (i.e., generator and transmission outages) on the grid. These contingencies are based on planning models of the transmission system with future demand scenarios to ensure continued compliance. When these models show violations, projects – particularly transmission projects – are considered to address these violations.

### 6.4.1 Methods for Analysis

Our analysis seeks to bound the total cost of transmission projects to which energy storage could contribute. Since there is insufficient publicly available data to run the same transmission planning models and scenarios to assess the violations seen in these scenarios, we rely on the NC Transmission Planning Collaborative's (NCTPC) list of projects and the explanations of need for the projects (NC Transmission Collaborative, 2017). This list describes projects that reflect the requirements of the NC system and where transmission is the best alternative given available options absent energy storage.

This list of projects does not give us enough specificity to determine the required energy storage capacity, or its value relative to other investment alternatives. However, we can qualitatively analyze whether in principle an energy storage could be applicable for a given project. The result gives an upper bound for the potential benefit of energy storage, assuming it can be used to meet the reliability standard. Given that transmission projects are on the order of tens of millions of dollars, there is potential for energy storage to serve as a cost-effective alternative. We note that the value of these transmission projects is not equivalent to the value of storage, but instead the cost of an alternative to storage.

New transmission investment is determined by the lowest cost options to address a reliability issue, which is frequently a thermal or voltage issue in the event of generator or transmission outages. To determine whether the new project addresses these issues, they are typically included in a power flow simulation of the system under these contingency conditions. To determine whether these issues could be mitigated with a storage project, a storage model would need to be included in this power flow analysis. Additionally, to determine the sizing of the energy storage system, contingency and system operating statistics related to the duration of the contingency event (i.e., mean time to repair and duration of load level) need to be considered to ensure that the storage project is sufficient to ensure reliability.

### 6.4.2 Analysis of Transmission projects

Descriptions of the proposed transmission projects are shown in Table 6.4.1 and the potential applicability of energy storage to these projects is explained in Table 6.4.2. For each transmission project, we indicate whether storage can be considered as an alternative to the transmission project to address the reliability issue in the planning models. Indicating that a transmission project could potentially be replaced by energy storage does not mean that storage will be cost-effective or even that energy storage can solve that exact issue in the required power flow study. However, the number of projects in which energy storage could be considered as an investment alternative sets an upper bound on the benefit that storage could yield. The required energy storage cannot be sized based on this data, so the cost of these projects cannot be determined and therefore the net benefit of energy storage as a solution cannot be given. Table 6.4.3 shows that the total cost of transmission projects which storage could be a potential alternative is \$283M of the \$425M in projects that are proposed.

#### Applicable Storage Technologies

In general, storage technologies with large capacities and several hours of duration are required to meet the overload potential of transmission in contingency situations and ensure reliability until the contingency has been cleared (e.g., generators brought online, transmission back in service, load conditions change). While some high capacity, long duration storage technologies such as pumped hydro and CAES could be used, in practice their applicability is highly constrained geographically. Batteries are the most likely candidate to provide this service.

**Table 6.4.1.** Proposed transmission projects with narratives and reasons for investment from NC Transmission Planning Collaborative (NC Transmission Collaborative, 2017).

<b>ID</b>	<b>Reliability Project</b>	<b>Needs Narrative</b>	<b>Description</b>	<b>Why is this the preferred solution?</b>	<b>NERC Category</b>
24	Durham - RTP 230 kV Line, Reconductor	With Harris Plant down, a common tower outage of the Method - (DPC) East Durham and the Durham - Method 230 kV Lines will cause an overload of the Durham 500 kV Sub - RTP 230 kV Switching Station Line.	Reconductor approximately 10 miles of 230 kV line with 6-1590 ACSR conductor.	Cost and feasibility. Reconductoring is much more cost effective.	P3 Violation
28	Brunswick #1 – Jacksonville 230 kV Line Loop-In to Folkstone 230 kV substation	This project is needed to alleviate loading on the Castle Hayne-Folkstone 115 kV Line under the contingency of losing Castle Hayne-Folkstone 230 kV Line.	Loop existing Brunswick Plant Unit 1 – Jacksonville 230 kV Line into the Folkstone 230 kV Substation. Also convert the Folkstone 230 kV bus configuration to breaker-and-one-half by installing three (3) new 230 kV breakers.	The selected project fixes additional transmission contingencies that the alternate solution does not.	P1 Violation
30	Raeford 230 kV Substation, Loop-in Richmond - Ft Bragg Woodruff St 230 kV Line and Add 3rd Bank	By 2018, with a Brunswick Unit down, loss of the common tower Fayetteville – Rockingham 230 kV and Fayetteville – Raeford 230 kV Lines may cause the Weatherspoon – Raeford 115 kV Line to overload. In addition, by 2018, the N-1-1 contingency of losing both of the Raeford	This project will require the loop-in of the Richmond – Ft. Bragg Woodruff St. 230 kV Line into the Raeford 230kV Substation and add a 300 MVA 230/115kV transformer.	Arabia substation had a higher cost and did not mitigate other contingencies of concern.	NERC Category P5 Violation



---

		230/115 kV, 200 MVA transformers at the Raeford 230 kV Substation may overload the Laurinburg - Raeford 115 kV Line. This project will mitigate each of these contingencies.	
<b>31</b>	Jacksonville - Grants Creek 230 kV Line and Grants Creek 230/115 kV Substation	The common tower outage of Jacksonville – Havelock 230 kV Line and Jacksonville – Jacksonville City 115 kV Line may cause the voltages in the Camp Lejeune area to fall below the planning criteria. Also, outage of the Jacksonville - New Bern 230 kV Line may cause the Havelock-Jacksonville 230 kV to overload.	The project scope consists of constructing a new 230 kV Line from Jacksonville 230 kV to a new 230 kV substation in the Grants Creek area. The 230 kV line shall be constructed with 6-1590 MCM ACSR or equivalent and will convert the existing Jacksonville - Havelock 230 kV Line into Jacksonville - Grants Creek 230 kV Line and Grants Creek - Havelock 230 kV Line. The new 230 kV Grants Creek Substation will be built with 4-230 kV breakers, a new 230/115 kV transformer, and tap into the Jacksonville City - Harmon POD 115 kV Feeder with 1-115 kV breaker.
			The alternate solution was determined to be infeasible due to routing challenges. P7 violation

---

32	Newport - Harlowe 230 kV Line, Newport SS and Harlowe 230/115 kV Substation	By summer 2020, an outage of the Havelock terminal of the Havelock - Morehead Wildwood 115 kV North Line will cause the voltages in the Havelock area to fall below planning criteria. The construction of this new line will mitigate this voltage problem.	Construct new 230kV Switching Station in the Newport Area, construct new 230kV Substation in the Harlowe Area, and construct the Newport Area - Harlowe Area 230kV line comprised of 3- 1590 MCM ACSR or equivalent. The Newport Area 230kV Switching Station will initially consist of a 3-breaker ring bus but should be laid out for future development as a standard 230/115 kV substation with breaker-and-a-half configuration in the 230kV yard. The Harlowe Area 230kV Substation will initially consist of one 200 MVA (or 300MVA), 230/115kV transformer and 3- 115kV breakers, and should be laid out for future development as a standard 230/115 kV substation with breaker-and-a-half configuration in the 230kV yard	The cost and construction feasibility is much better with selected alternative: Convert Havelock-Morehead Wildwood115 kV North Line to 230 kV.	P1 violation
33	Fort Bragg Woodruff St 230 kV Sub, Replace 150 MVA 230/115 kV Transformer with Two 300 MVA Banks & Reconductor Manchester 115 kV Feeder	In 2016/17 winter, during peak load conditions, load on the Ft. Bragg Woodruff Street - Manchester 115kV Feeder were projected to exceed the feeder capacity and the transformer bank rating at the Ft. Bragg Woodruff Street 230kV Substation. DEP worked with South River EMC and Central EMC to manage the loading on this feeder for several years and we jointly agreed that this	Replace the existing 150 MVA, 230/115 kV transformer bank (three 1-phase & spare 50 MVA) at the Ft. Bragg Woodruff Street 230kV Substation with two 3-phase 300 MVA, 230/115 kV transformers from Apex US#1 230kV Substation per Equipment Engineering. Two 115 kV circuit breakers with associated disconnect switches will be installed. Also reconductor the Ft. Bragg Woodruff Street - Manchester 115kV Feeder (4.42 miles) with 3-1590 MCM ACSR or equivalent.	Cost and feasibility is much improved with selected alternative: Convert 115 kV feeder to 230 kV.	P1 violation

---

was the best alternative to alleviate these issues.

---

<b>34</b> Sutton - Castle Hayne 115 kV North Line - Rebuild	By 2019, with all area generation online, the loss of the Sutton Plant - Castle Hayne 115 kV South Line will cause the Sutton Plant - Castle Hayne 115 kV North Line to exceed its thermal rating.	This project consists of rebuilding the Sutton Plant – Castle Hayne 115 kV North Line using 1272 MCM ACSR conductor or equivalent (approximately 8 miles). The line traps at both Sutton and Castle Hayne terminals will be removed in conjunction with the installation of OPGW. The 800A current transformers at both line terminals will have to be updated as part of this project. The thermal rating of this line will then be limited to 239 MVA due to the 1200 A disconnects at both terminals.	Cost and feasibility is much improved with selected alternative: Convert 115 kV feeder to 230 kV.	P1 violation
---	--	--	---	--------------

---

36	Asheville Plant, Replace 2-300 MVA 230/115 kV Banks with 2-400 MVA Banks, Reconductor 115 kV Ties to Switchyard, Upgrade Breakers, and Add 230 kV Capacitor Bank	This project consists of upgrading Asheville Plant to interconnect two combined cycle units. The project includes upgrading the existing 230/115 kV transformers to 400 MVA each, reconductoring the 115 kV north and south transformer tie lines, replacing breakers, and adding a 230 kV capacitor bank.	There was no feasible alternative	P3 Violation	
37	Cane River 230 kV Substation, Construct 150 MVAR SVC	This project consists of upgrading Cane River 230 kV Substation by adding a 150 MVAR 230 kV static VAR compensator (SVC).	It was determined that construction new interconnections was not feasible.	Category B violation	
39	Asheboro-Asheboro East 115kV North Line Reconductor	This project consists of rebuilding/reconductoring approximately 6.5 miles of the existing 115kV line using 3-1590 or equivalent conductor. This project requires the replacement of disconnect switches at Asheboro 230kV and the replacement of the breaker, the disconnect switches, and the 115 kV east bus at Asheboro East 115kV associated with this line. Both ends of the line will also require CT/metering equipment upgrades such that they are not the limit to the line rating. The upgraded equipment for this line should be 2000 amp minimum.	Cost and Feasibility	P3 Violation	
38	Harley 100 kV Lines (Tiger -Campobello) Reconductor	Under high levels of transfer to CPLW, these lines may become overloaded because they are on one of the two 100 kV paths that	This project consists of rebuilding 11.8 miles of the existing 336 ACSR conductor with 1158 ACSS/TW	New transmission line(s) would require additional right-of-way, adding to the cost of the project	P7 Violation

		connect DEC to CPLW.			
40	Delco 230kV Substation, Convert to Double Breaker	The conversion of the Delco 230kV bus scheme will improve system reliability and thereby reduce interruption exposure to the customers in the area in case of an event; while maintaining compliance with NERC Transmission Planning Standards.	This project consists of relocating the Cumberland and Brunswick Plant East 230kV Line Terminals, converting the Sutton Plant 230kV Terminal and Brunswick Plant 230kV West Terminal to a double breaker scheme, and converting the Cumberland 230kV Terminal and Brunswick Plant 230kV East Terminal to a double breaker scheme.	There is no feasible alternative	P4 Violation
41	Castle Hayne 230kV Substation, Convert to Double Breaker	The conversion of the Castle Hayne 230kV bus scheme will improve system reliability and thereby reduce interruption exposure to the customers in the area in case of an event, while maintaining compliance with NERC Transmission Planning Standards.	This project consists of relocating the Sutton Plant 230kV and Folkstone 230kV Line Terminals, converting the new Folkstone 230kV Terminal and Wilmington Corning 230kV Terminal to a double breaker scheme, and converting the new Sutton Plant 230kV Terminal and Brunswick Plant Unit 1 230kV Terminal to a double breaker scheme.	There is no feasible alternative	P4 Violation
42	Rural Hall 100 kV, Install SVC	Installation of a SVC at Rural Hall will mitigate voltage concerns driven by certain contingency conditions in DEC	This project consists of installing a - 100/+300 MVAR SVC at Rural Hall 100 kV.	Solution can be implemented quicker than new generation and at a lower cost.	-

---

43	230/100 kV Tie Station, Catawba County NC	The installation of this new 230/100 kV tie station will provide greater ability to meet local load growth and maintain compliance with NERC Transmission Planning Standards.	This project consists of installing a 230/100 kV tie station in Catawba County, NC.	Ability to meet local load growth.	-
----	---	---	---	------------------------------------	---

---

**Table 6.4.2.** Proposed transmission projects and potential for storage as alternative.

ID	Reliability Project	Owner	Projected In-Service Date	Estimated Cost (\$M)	Lead Time (years)	Storage Applicability	Reason
24	Durham - RTP 230 kV Line, Reconductor	DEP	TBD	15	4	Potentially Applicable	Storage could potentially alleviate some of the capacity limits for limited time in the case of Harris outage. However, this applicability of storage would require modeling of the duration of conditions which would cause line overload during the contingency event.
28	Brunswick #1 – Jacksonville 230 kV Line Loop-In to Folkstone 230 kV substation	DEP	6/1/2024	14	4	Potentially Applicable	Storage could alleviate the need for new substation for N-1 contingency event. storage has ability to provide power injection for limited period of time until contingency is resolved or load condition changes. To better understand applicability of storage to contingency, studies would need to examine effect on other contingencies the current alternative fixes as well as study of time

to repair and load conditions that would cause violation.

30	Raeform 230 kV Substation, Loop-in Richmond - Ft Bragg Woodruff St 230 kV Line and Add 3rd Bank	DEP	6/1/2018	15	1 Potentially Applicable	Post-contingency, battery could be used to provide local generation until load fell below where low voltage conditions exist. The applicability of energy storage depends on whether condition is expected to occur at peak or off-peak conditions and mean time to repair of line.
31	Jacksonville - Grants Creek 230 kV Line and Grants Creek 230/115 kV Substation	DEP	6/1/2020	51	Potentially Applicable	Storage could limit need for additional lines and upgraded substation. Storage could limit the thermal overload on the line for duration of contingency.



32	Newport - Harlowe 230 kV Line, Newport SS and Harlowe 230/115 kV Substation	DEP	6/1/2020	70	2	Potentially Applicable	Post-contingency, battery could be used to provide local generation until load fell below where low voltage conditions exist. The applicability of energy storage depends on whether condition is expected to occur at peak or off-peak conditions and mean time to repair of line.
33	Fort Bragg Woodruff St 230 kV Sub, Replace 150 MVA 230/115 kV Transformer with Two 300 MVA Banks & Reconductor Manchester 115 kV Feeder	DEP	2/24/2017	19 -	Potentially Applicable	Storage could provide backup power to reduce load on transformer during contingency event	
34	Sutton - Castle Hayne 115 kV North Line - Rebuild	DEP	6/1/2019	11	Potentially Applicable	Storage projects could be considered as an alternative to transmission projects to reduce the thermal load on the 115 kV line around the Sutton-Castle Hayne generators.	

36	Asheville Plant, Replace 2-300 MVA 230/115 kV Banks with 2-400 MVA Banks, Reconductor 115 kV Ties to Switchyard, Upgrade Breakers, and Add 230 kV Capacitor Bank	DEP	12/1/2019	40	2	Not Applicable	Project is to interconnect generation.
37	Cane River 230 kV Substation, Construct 150 MVAR SVC	DEP	12/1/2019	42	2	Not Applicable	Storage cannot provide reactive power as well as SVC.
39	Asheboro-Asheboro East 115kV North Line Reconductor	DEP	6/1/2019	12		Potentially Applicable	Storage could potentially alleviate some of the capacity limits for limited time in the case of Harris outage. However, this applicability of storage would require modeling of the duration of conditions which would cause line overload during the contingency event.
38	Harley 100 kV Lines (Tiger -Campobello) Reconductor	DEC	12/1/2021	18	3	Potentially Applicable	Storage could be used to reduce overloads on line during times of high DEC to CPLW transfer. Storage has potential for benefits to avoiding additional generation need in highly constrained region.

40	Delco 230kV Substation, Convert to Double Breaker	DEP	6/1/2019	13	1.5	Potentially Applicable	Energy storage could be used for reliability to reduce exposure of customers to reliability events. A local source of power injections for limited periods of time can alleviate concerns with these high impact, low probability events.
41	Castle Hayne 230kV Substation, Convert to Double Breaker	DEC	6/1/2019	10	1.5	Not Applicable	Stuck breaker failing to clear fault is unlikely to be alleviated by storage
42	Rural Hall 100 kV, Install SVC	DEC	6/1/2020	50	2	Not Applicable	Storage could be used for voltage support for system reliability events as alternative to SVC with added benefit of real power control as well.
43	230/100 kV Tie Station, Catawba County NC	DEC	12/1/2021	45	2.5	Potentially Applicable	Storage can provide some relief for peak load and high transmission capacity periods. Further comparison of the expectation of load growth and level of transmission capacity that is exceeded in those cases.

**Table 6.4.3.** Summary of transmission project costs by potential for energy storage as alternative

<b>Storage Alternative Potential</b>	<b>Number of Projects</b>	<b>Cost (\$M)</b>
Not Applicable	4	142
<b>Potentially Applicable</b>	<b>11</b>	<b>283</b>
Total	15	425

Other state-level energy storage studies also indicate a significant potential value for energy storage to reduce the need for new and replacement transmission assets. However, like this NC-based study, these studies do not have an estimate of transmission investment value alone and are limited by the availability of detailed system models. The Massachusetts study (Massachusetts, 2016) uses detailed transmission and generation data to estimate the value of reduced loading on transmission assets, including lines and transformers, but does not include a break down. Massachusetts finds significant value to ratepayers for transmission and distribution cost reduction (\$305M) but does not identify value from a transmission investment reduction only. New York’s energy storage roadmap (NYSERDA, 2018) focuses on other services that the bulk power system provides, but does not include the value of transmission investment deferral. The Vermont energy storage study (Vermont, 2017) qualitatively discusses how energy storage provides value to the transmission system, but does not attempt to estimate this value.

In general, these studies agree that energy storage has significant potential to reduce transmission investment costs. However, neither this study nor other state studies have a clear value to the system and ratepayer for this service.

## References

- Massachusetts Department of Energy Resources; Massachusetts Clean Energy Center. “State of Charge: Massachusetts Energy Storage Initiative.” 2016. <https://www.mass.gov/service-details/energy-storage-study>.
- NERC. “Standard TPL-001-4 — Transmission System Planning Performance Requirements” 26 November 2014 <https://www.nerc.com/pa/Stand/Reliability%20Standards/TPL-001-4.pdf>.
- NC Transmission Planning Collaborative (2017). “Report on the NCTPC 2017-2027 Collaborative Transmission Plan: Final Plan.” [http://www.nctpc.org/nctpc/document/REF/2018-01-16/2017-2027\\_NCTPC\\_Report\\_01\\_16\\_2018\\_FINAL.pdf](http://www.nctpc.org/nctpc/document/REF/2018-01-16/2017-2027_NCTPC_Report_01_16_2018_FINAL.pdf).
- New York State Energy Research and Development Authority (NYSERDA). (2018). *New York State Energy Storage Roadmap*. Online at: <https://www.nyserd.ny.gov/All%20Programs/Programs/Energy%20Storage/Achieving%20NY%20Energy%20Goals/The%20New%20York%20State%20Energy%20Storage%20Roadmap>
- Vermont Dept. of Public Service. “Vermont Energy Storage Study,” 15 November 2017. [http://publicservice.vermont.gov/sites/dps/files/documents/Pubs\\_Plans\\_Reports/Energy\\_Storage\\_Report/Storage\\_Report\\_Final.pdf](http://publicservice.vermont.gov/sites/dps/files/documents/Pubs_Plans_Reports/Energy_Storage_Report/Storage_Report_Final.pdf).

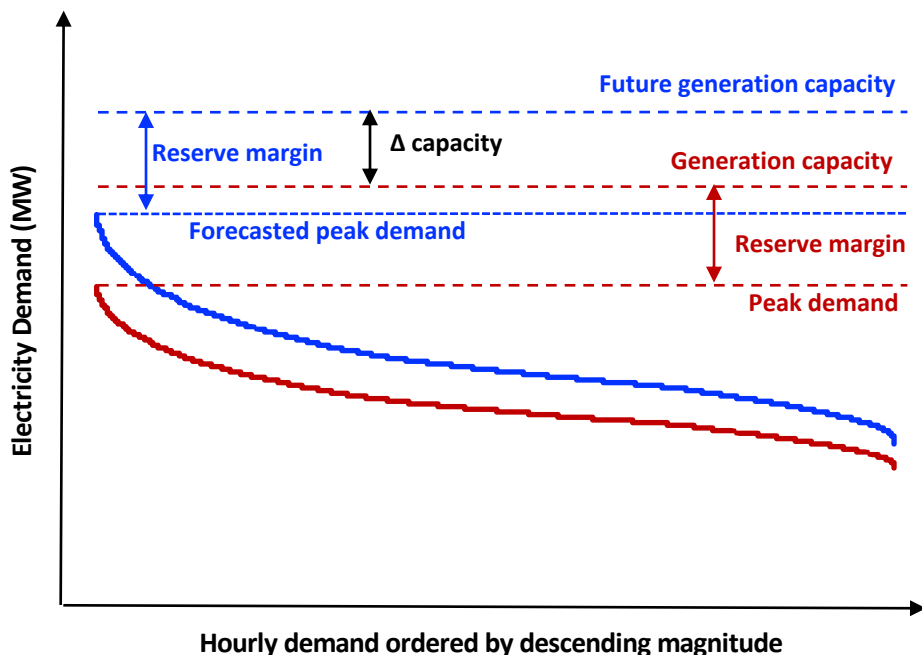
## 6.5. Bulk Energy Time Shifting and Peak Capacity Deferral

In this section, we evaluate the value of storage to perform two related functions. First, storage can be used to reduce system-wide peak demand, which can reduce or eliminate the costs associated with constructing new peaking generation units. Second, storage can be charged during low demand periods and discharged during high demand periods, thus producing bulk shifts in electricity supply that flatten the demand curve and reduce overall system costs.

### 6.5.1 Peak Generation Capacity Deferral

In electric power systems, the balance between supply and demand has to be maintained at all times to ensure reliable service. Therefore, it is critical for utilities to secure adequate generation capacity to serve the peak system load plus an adequate reserve margin to account for load forecast errors and generator outages. The high demand on the system, however, occurs over only a few hours per year but can be a significant driver of total costs. Generation capacity must be built to provide service for these short periods each year, and generators used only during peak load conditions typically have the high marginal costs.

Figure 6.5.1 provides a stylized illustration of the future power generation capacity that would be needed to satisfy the system's forecasted peak load and the necessary reserve margin in a capacity expansion study. This figure, termed a *load duration curve*, shows hourly demand over one year sorted from highest to lowest. With load growth, the demand profile shifts up and the current generation capacity of the system cannot meet the peak demand. This means that new generation capacity would need to be added to the system to ensure future reliable operations.



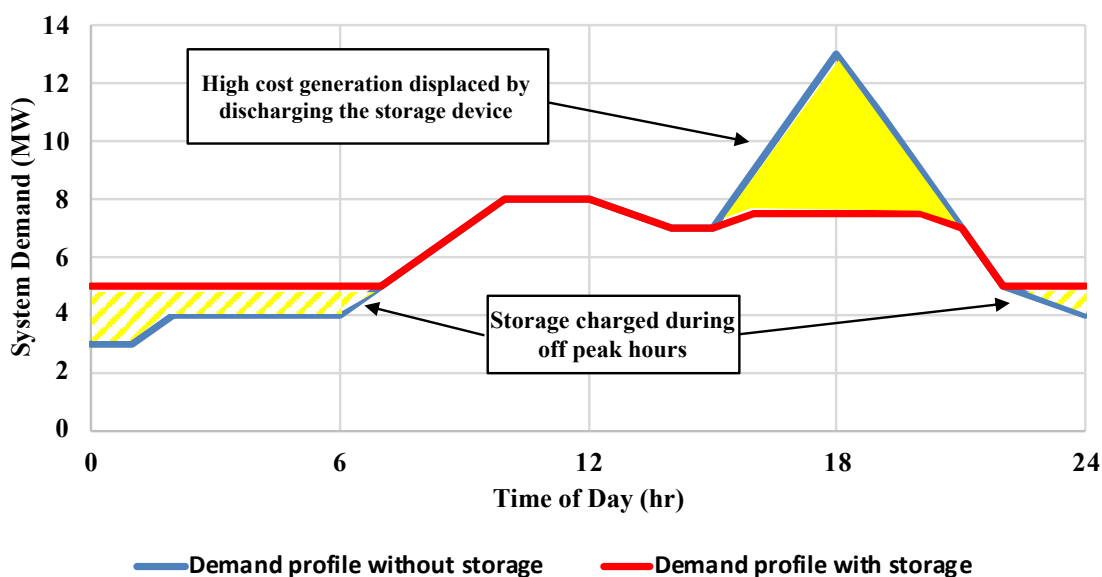
**Figure 6.5.1.** Basic illustration of generation capacity needed to reliably meet future peak loads. Elements in red represent the existing system parameters, elements in blue represent future projections, and the difference between future and existing generation capacity represents the additional generation capacity required to satisfy the projected peak load.

Reducing peak electricity demand can eliminate the need for new power generation capacity, thereby reducing the system-wide costs, which in turn produce cost savings for consumers. Energy storage technologies can be operated to meet this peak demand, eliminating the need for new investments in generation capacity that have low utilization rates.

### 6.5.2 Bulk Energy Time Shifting

The system-wide cost of generation varies throughout the day, with off-peak hours typically incurring marginal costs far lower than those during on-peak hours. Energy storage can charge during low-cost off-peak hours and discharge during higher cost on-peak hours, reducing the system-wide operational costs. We term this application “bulk energy time shifting.”

Figure 6.5.2 illustrates the demand profile of a hypothetical system with and without energy storage. Note that cheaper electricity is used during off-peak demand periods to charge the energy storage system. During peak hours the energy storage system is discharged to satisfy a portion of the system’s electricity demand. Assuming that the value of the difference in marginal costs is sufficient, this application for energy storage would reduce overall costs and displace the need for using expensive generation resources that would be required in the absence of storage.



**Figure 6.5.2.** Demand profile with and without energy storage.

While generation capacity deferral applications of energy storage provide system value by displacing the need for more capacity (MW) of new generation, bulk energy time shifting applications provide value by shifting the timing of energy generation (MWh). While these are two distinct value streams, in practice, one energy storage system can readily provide both services. By discharging stored energy during peak hours, the energy storage system could reduce both system energy costs and the need to additional generation capacity. In our analysis, we model the operation of energy storage to provide both of these services and recognize both value streams.

### 6.5.3 Modeling Approach

For the purpose of this portion of the study, we use an energy system optimization model called Tools for Energy Modeling and Optimization Analysis – Temoa (Hunter et al., 2013). Temoa is used for two purposes: capacity expansion planning and operational dispatch analysis. Temoa is an open source, bottom-up energy system optimization model, similar to other models such as MARKAL/TIMES (IEA, 2004), OSeMOSYS (Howells et al., 2011) and MESSAGE (IIASA, 2011). Recent work that employs Temoa to large scale systems can be found in Eshraghi et al. (2018), where the authors analyze the US energy system in the absence of climate policy.

Temoa employs linear optimization to identify the least-cost pathway for energy system development. The model objective function minimizes the system-wide present cost of energy provision over a user-specified time horizon by optimizing the installation and utilization of energy technologies across the system. Technologies in Temoa are explicitly defined by a set of engineering-economic parameters (e.g., capital costs, operations, fuel and maintenance costs, conversion efficiencies) and are linked together in an energy system network through a flow of energy commodities. Model constraints enforce rules governing energy system performance, and user-defined constraints can be added to represent limits on technology expansion, fuel availability, and system-wide emissions. The model formulation is detailed in (Hunter et al., 2013) and the Temoa source code is freely available on Github (<https://github.com/TemoaProject>). As the model formulation tends to evolve over time, the revised model documentation can be found on the project website (<http://temoaproject.org/>).

Recent model formulation enhancements in Temoa, including the definition of flow balance constraints for storage devices and ramping constraints for power generators, allow us to perform economic dispatch analysis (operational analysis) in addition to the overall capacity expansion analysis. We use Temoa to determine the power generation dispatch with an hourly resolution over the course of one year. More details about this process are described in the following sections.

#### **Step 1: Determine new generation build outs through a capacity expansion optimization**

In the capacity expansion analysis, we determine the least cost build plans of generation technologies needed to meet future demand. The analysis horizon is defined from 2017 to 2030, with a total of four decision periods (2017, 2020, 2025 and 2030). In 2017, no new investments are allowed in generation capacity to reflect a precise representation of the existing system. Temoa represents intra-annual variations in energy supply and end-use demands by dividing one year into a limited number of time slices that represent combinations of different seasons and times-of-day. During the representative year, the model optimizes the supply to meet demand in each time slice.

For the purpose of the combined analysis of generation capacity deferral and bulk energy time shifting, we consider a set of seven distinct scenarios that represent different capacity expansion plans for the system being analyzed. Summary descriptions of each scenario are presented in Table 6.5.1. The baseline data is described in Appendix C.

**Table 6.5.1.** Summary of capacity expansion scenarios used to define 2030 build out plans

Capacity Expansion Scenario		Brief Description
S01	Base Case	This scenario includes base case assumptions for fuel prices from the Annual Energy Outlook (EIA, 2018a) and capital cost assumptions from the NREL Annual Technology Baseline (NREL, 2018). We represent the service territory of Duke Energy Carolinas (DEC) and Duke Energy Progress (DEP) in North Carolina and South Carolina. We represent electricity demand from 2017 from (EIA, 2018b) and consider an annual increase in load of 1.2% until 2030. We represent power interchanges among adjacent regions, parameterized with data from (EIA (2018b), which is held constant over time. Existing generators are represented at the plant level, and costs, efficiencies, capacities, ramping and other characteristics were obtained from EIA (2018c) and EIA (2018d). We assume a minimum of 6.8 GW of total solar photovoltaic (PV) generation in the system to be deployed until 2022, consistent with HB589. This scenario complies with the current renewable energy and energy efficiency targets of 12.5% by 2021.
S02	Duke 2018 Integrated Resources Plan (IRP)	In this scenario, we do not optimize capacity expansion with Temoa. Instead, we assume the generation capacity used in the Base scenario of Duke Energy's most recent Integrated Resources Plan.
S03	Expanded Renewable Energy and Energy Efficiency Portfolio Standard (REPS)	In this scenario, we assume an expanded REPS, in which a minimum of 40% of North Carolina's retail sales by renewable energy sources by 2030. This target increases linearly between 2018 and 2030.
S04	Clean Energy Standard (CES)	In this scenario, we assume that 60% of North Carolina's retail electricity sales must be met by carbon-free or low carbon sources, including nuclear, coal with carbon sequestration, solar, wind, and hydro, by 2030.
S05	Carbon Cap	In this scenario we limit CO <sub>2</sub> emissions to a level based on a statement from the Duke's 2017 Climate Report to Shareholders, which aims to achieve a 40% reduction below 2005 CO <sub>2</sub> emissions levels by 2030.
S06	High Natural Gas Prices	In this scenario, we assume the high natural gas projections from the Annual Energy Outlook from 2018 (EIA, 2018a), where the cost for natural gas is \$7.58/MMBtu, representing an 89% increase over the baseline projection in 2030.
S07	High Electric Vehicle Penetration	In this scenario, we assume that 25% of vehicle miles traveled in 2030 in North Carolina will be by electric vehicles (EVs). We assume a total of 116 billion vehicle miles traveled per year in NC (US DOT, 2016) and use an estimate of 4 miles/kWh as the electricity consumption for EVs (CleanTechnica, 2018). This will add 7.3 TWh per year of electricity demand by 2030. To represent the daily charging profiles, we use data from 300 EVs from Muratori (2018) over the course of one year and scale the average hourly charging to yield the system-wide total.

Figure 6.5.3 provides a flow chart of the use of Temoa to determine the capacity expansion build out plans for each of the analysis scenarios.



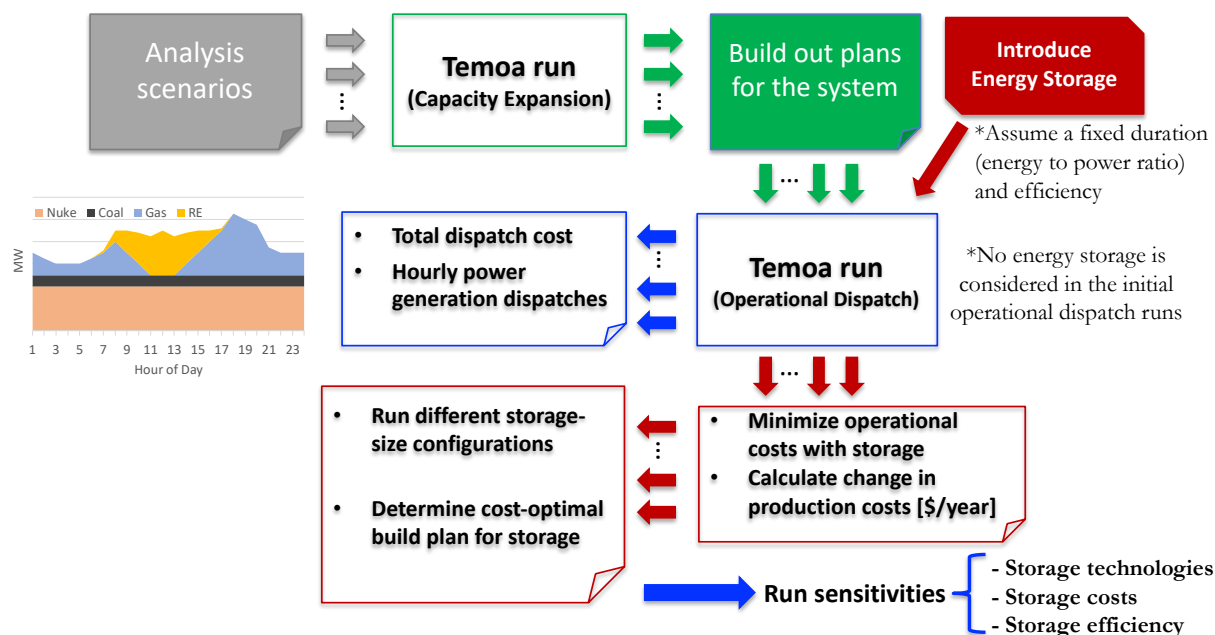


**Figure 6.5.3.** Illustration that depicts the process to run Temoa as a capacity expansion model.

In this analysis, we consider the representation of a demand profile for an average day in each of four seasons. For each representative year, a total of 96 time slices (24 per season) are represented within the model. The spring season is defined here from March through May, summer from June through August, autumn from September through November, and winter from December through February.

**Step 2: Determine least cost operation of the power system with economic dispatch model**

After determining the optimal build plans for new capacity, we utilized the operational version of Temoa to optimize power system operational dispatch. At this stage, only operational decisions associated with existing and planned capacity, as determined by the build out plans, can be optimized in order to minimize cost. In addition, for this operational analysis, we increase the temporal resolution to 8760 hours/year to better capture hourly power system behavior throughout the year. Figure 6.5.4 provides a flow chart that outlines how hourly operations are determined for each of the generation build out plans.



**Figure 6.5.4.** Illustration that depicts the process to run Temoa as operational dispatch model.

For each scenario, we first model the results with no energy storage to determine baseline operations, allowing us to isolate the impacts associated with the introduction of energy storage. This results in a total of seven modeling runs (one for each scenario defined by the capacity expansion study, listed in Table 6.5.1) without energy storage. These results provided us with baseline information on the least cost operation of the grid in the absence of energy storage.

### Step 3: Introduce energy storage in economic dispatch analysis

Once the initial operational dispatch runs for each generation build-out are performed, another set of operational runs are necessary to evaluate the benefits of storage in the system. In the second set of operational model runs, we introduce energy storage (including different sizes, durations, and technologies) to evaluate changes to power dispatch and determine the optimal energy storage charge and discharge decisions that satisfy the system demand at minimum operational cost. We note that energy storage deployment is not defined within the capacity expansion analysis, but exogenously added to the operational model to analyze its performance across a wide range of design configurations.

Table 6.5.2 presents the set of duration and power ratings that we consider in this analysis. The storage configuration name (e.g., S-1GW/1GWh) includes both the power rating (GW) and energy storage capability (GWh). Each storage technology that is considered in this part of the study assumes a subset of power/duration configurations from the summary defined in Table 6.5.2. Therefore, each configuration assumes a fixed duration for the storage technology (energy to power ratio).

**Table 6.5.2.** Summary of the storage configurations

Power/Duration	1 hour	2 hours	4 hours	8 hours
0.3 GW	S-0.3GW/0.3GWh	S-0.3GW/0.6GWh	S-0.3GW/1.2GWh	S-0.3GW/2.4GWh
1 GW	S-1GW/1GWh	S-1GW/2GWh	S-1GW/4GWh	S-1GW/8GWh
3 GW	S-3GW/3GWh	S-3GW/6GWh	S-3GW/12GWh	S-3GW/24GWh
5 GW	S-5GW/5GWh	S-5GW/10GWh	S-5GW/20GWh	S-5GW/40GWh

For each of the power generation plans determined by the capacity expansion model, we perform up to 13 operational model runs from the set of energy storage configurations considered (i.e., those listed in Table 6.5.2 and a case without storage). Here the letter “S” corresponds to the energy storage technology acronym, e.g., in the case of lithium-ion batteries “S” will be substituted by “LI”. Besides lithium-ion (LI) batteries we consider flow batteries (FB), pumped hydro storage (PSH) and compressed air energy storage (CAES) systems in this analysis. We were only able to run CAES under the Base and Expanded REPS scenarios due to limited modeling time. We consider all power configurations and durations of 1, 2 and 4 hours listed in Table 6.5.2 for LI and FB, and duration of 8 hours for CAES and PSH. Thus, a total of 174 operational model runs were conducted for LI and FB (87 for each), 8 for CAES, 28 for PSH, and 7 without storage, totaling 217 operational runs in order to assess the value of peak generation capacity deferral and bulk energy time shifting by storage.

For each of the energy storage configurations, the model determines the optimal charge and discharge decisions for storage to minimize system operational costs. We then compare the total system operational costs with and without energy storage to determine the overall change in energy cost. In a system with energy storage, its operation would reduce or eliminate the operation of the most expensive generation resources, which were previously used to satisfy the peak load in the operational runs without energy storage.

#### Step 4: Determine the net economic benefits of energy storage across a range of configurations

After the operational runs are performed for a given combination of capacity expansion plan, storage technology, and energy/power ratio, the costs and benefits are evaluated to determine the cost-optimal build plans for energy storage. In this analysis, we consider the computation of two components that are used to assess the benefits associated with the use of an energy storage device in power systems: net energy cost savings and capacity value, which we refer to as “energy benefits” and “capacity benefits,” respectively.

The energy benefits are computed as the difference between the system-wide operational costs with and without energy storage. This computation is defined in (1):

$$ES_i^k = TC_{NS} - TC_i \quad \forall i \in I_k, \forall k \in K \quad (1)$$

where we consider a set of storage technologies defined by  $k \in K$  and a set of storage configurations associated with technology  $k$  defined by  $i \in I_k$ ;  $TC_{NS}$  represents the total operational costs in (\$/year) from the operational model run when the system does not consider storage and  $TC_i$  represents the total dispatch costs in (\$/year) from the operational model run when the system has storage under configuration  $i$ ;  $ES_i^k$  represents the energy benefits in (\$/year) for the system when considering storage technology  $k$  and storage configuration  $i$ .

The capacity benefits for energy storage are computed using the average annual capacity credit calculations from Sioshansi et al. (2014) and the cost of new entry (CONE) for a natural gas combustion turbine power generator. This computation is defined in (2):

$$CV_i^k = (ECP_i \times P_i) CONE \quad \forall i \in I_k, \forall k \in K \quad (2)$$

where  $CV_i^k$  is the capacity benefit for energy storage considering technology  $k$  and configuration  $i$  (in \$/year);  $ECP_i$  is the capacity credit (in %) for storage configuration  $i$  defined as 41%, 56% and 75% for storage technologies of 1, 2 and 4 hours of duration (Sioshansi et al., 2014);  $P_i$  is the rated power capacity from storage configuration  $i$  (in kW);  $CONE$  is the cost of new entry associated with a natural gas combustion turbine (in \$/kW-year). The  $CONE$  adopted here follows the methodology used by PJM (Newell et al., 2018), and represents the capital investment and fixed operating cost of a new generation resource that is used as backup capacity and, therefore, does not include any variable costs.

The total benefits of deploying storage technology  $k$  considering configuration  $i$  can be defined using (3):

$$SB_i^k = ES_i^k + CV_i^k \quad \forall i \in I_k, \forall k \in K \quad (3)$$

The values of  $SB_i^k$  (in \$/year) are then compared with the yearly revenue requirements for the storage technology included in the accompanying spreadsheet. While we analyzed the benefits of each technology and configuration separately, we aim to identify among the various options which

of the alternatives provides the largest net benefits to the system. Therefore, Equation (4) identifies, for each technology, which configuration provides the largest benefits to the system:

$$\max\{SB_i^k - (CAP_i \times RR_i^k)\} \tag{4}$$

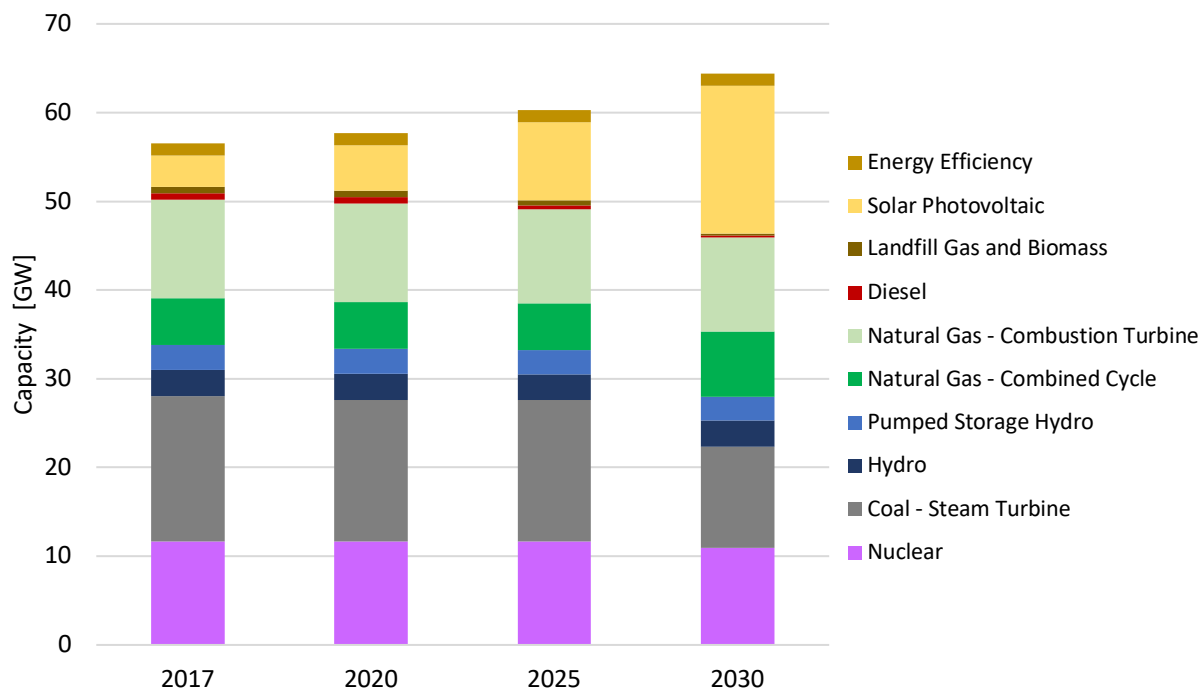
Where  $RR_i^k$  is the revenue requirement in (\$/kWyr) for configuration  $i$  and technology  $k$ .

In addition, we consider and discuss the potential economic benefits associated with CO<sub>2</sub> emissions reductions for two of the analysis scenarios.

### 6.5.4 Results and Discussion

#### Capacity Expansion Results

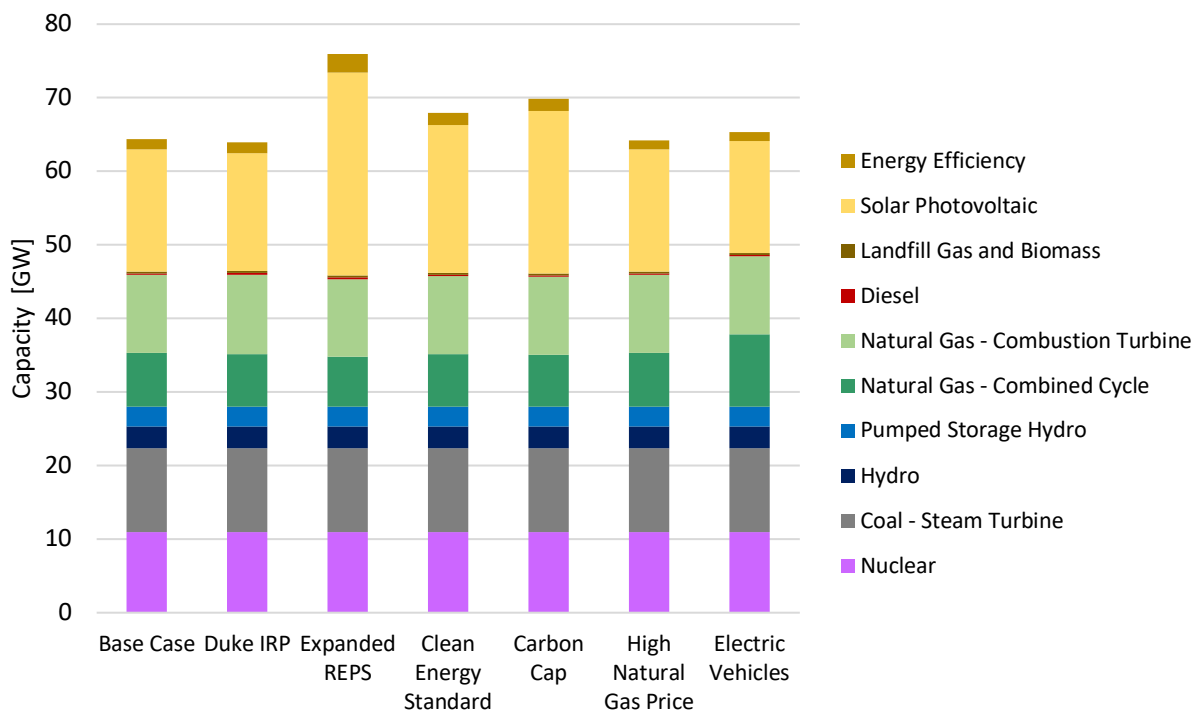
The least cost installed generation capacity for the Base Case is reported in Figure 6.5.5. We observe an increase in the installed solar PV capacity from 3.6 GW in 2017 to 16.6 GW in 2030. Over the same period, natural gas capacity increases from 16.4 GW in 2017 to 18.0 GW in 2030, coal capacity decreases by 31%, from 16.4 GW to 11.4 GW; nuclear capacity drops 0.7 GW; and hydro power capacity remains constant.



**Figure 6.5.5.** Installed generation capacity by technology in the Base Case.

Figure 6.5.6 shows the 2030 results for the seven capacity expansion scenarios described in Table 6.5.1. The biggest differences in the results are driven by a tradeoff between solar PV and natural gas. For the Expanded REPS and Carbon Cap scenarios, we see a substantial increase in solar PV, increasing from 16.6 GW in the Base Case to 27.6 GW and 22.1 GW, respectively, while natural gas capacity drops slightly in both scenarios (-0.6 GW and -0.3GW, respectively). The other scenarios (Duke IRP, Clean Energy Standard, High Natural Gas Price, and Electric Vehicles) have installed

generation portfolios in 2030 similar to the base case. Note that Figures 6.5.5 and 6.5.6 show the generation capacity (GW) that is built in each scenario; the energy generation (MWh) across these system configurations varies greatly.

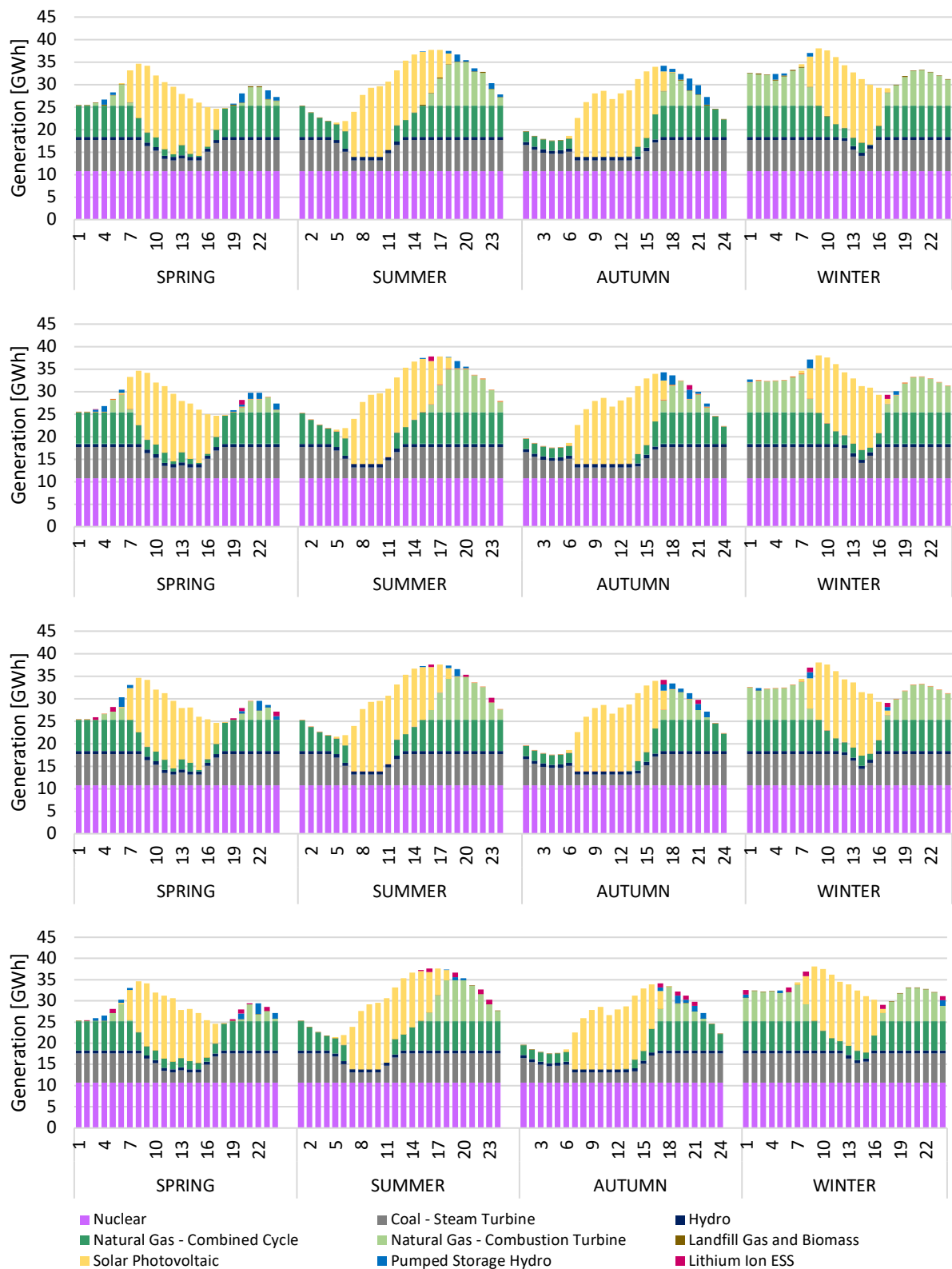


**Figure 6.5.6.** Installed generation capacity in 2030 across the seven modeled scenarios.

### Power Generation Operational Dispatch

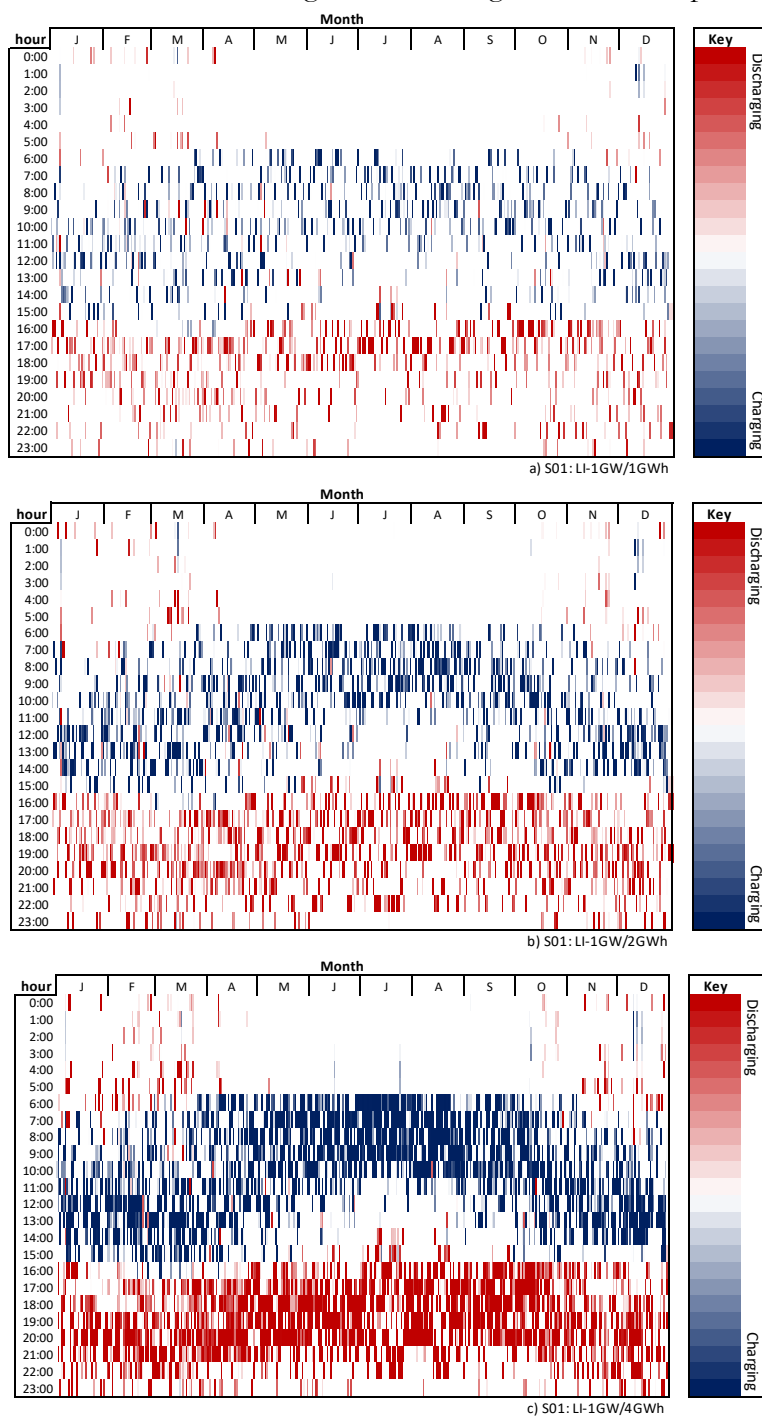
The power generation capacities defined by the Temoa capacity expansion runs in each scenario up to 2030 are “locked in” for the operational dispatch analysis, which is discussed in this section. Figure 6.5.7 presents the operational dispatch results for the Base Case considering runs without the addition of new energy storage technology (NS), with the addition of a 1 GW lithium-ion battery with 1 hour of duration (LI-1GW/1GWh), 2 hours of duration (LI-1GW/2GWh), and 4 hours of duration (LI-1GW/4GWh). We obtain results for all 8,760 hours of the year; for simplicity, the results here show the peak day in each of the four seasons. We note that at longer durations of energy storage, more generation across the system is shifted, displacing mostly natural gas CT generation during times when the system has a high demand and solar generation is not available. Results for operational dispatch considering lithium-ion batteries of 0.3 GW, 3 GW and 5GW for the same peak days can be found in Appendix B.

The results observed for the peak days follow a similar pattern for the other days of the year, where energy storage helps by shifting electricity supply in time in a way that reduces operational costs.



**Figure 6.5.7.** Hourly generation dispatch for the peak day in each season in the base case. The following configurations are plotted: (a) NS, (b) LI-1GW/1GWh, (c) LI-1GW/2GWh and (d) LI-1GW/4GWh.

Figure 6.5.8 presents charge and discharge decisions across the 8760 hours of the year for the Base Case considering different lithium-ion storage device configurations in the power system.



**Figure 6.5.8.** Hourly charge/discharge decisions for Li-ion batteries in the Base Case, assuming 1 GW of storage capacity and different durations: 1-hour (top), 2-hour (middle), and 4-hour (bottom). We note that charging actions are occurring mostly from Hours 7 to 15 with variations across the seasons. These hours correspond to low generation costs induced by solar generation coming online. The storage enables a higher level of solar generation utilization during the day, at times reducing solar curtailment. The batteries are predominately discharged during the peak periods, including

evenings and winter mornings, satisfying demand during high cost hours and avoiding electricity production from less efficient gas combustion turbines. We note also that discharge profiles vary across the year and that storage devices are used during the winter season to satisfy early morning system demand. As the size of the storage device increases, the charge and discharge magnitude also increases, as shown in Figure 6.5.8. Results for charge/discharge profiles of other storage technologies and configurations can be found in Appendix B.

### Capacity Benefits for Energy Storage

First, we compute the capacity credit for each storage configuration based on the ECP values defined in Sioshansi et al. (2010). Table 6.5.3 shows the capacity credit and capacity benefits for each storage configuration. The capacity credit for each storage configuration is obtained by computing  $ECP_i \times P_i$ . Using the computed capacity credit, we estimate the capacity benefits in millions of dollars per year (\$M/year) using (2) and a calculated CONE for natural gas combustion turbines of \$113/kWyr. By dividing the capacity benefits in (\$M/year) by the power capacity in GW of the storage device, we obtain the capacity benefits (in \$/kWyr), as reported in Table 6.5.4. We note that the capacity credit and the respective capacity benefits are highly dependent on the ECP values. Therefore, storage devices designed with longer duration received a higher capacity credit due to the higher ECP value. The capacity benefits expressed in (\$M/year) are higher for larger storage devices, however, when we compute the capacity benefits in (\$/kWyr), the values are the same for a specific storage duration.

**Table 6.5.4.** Capacity credit and capacity benefits for each energy storage configuration

Duration (hours)	ECP (%)	Capacity Credit (GW)				Capacity Benefits (\$M/year)				Capacity Benefits (\$/kWyr)			
		0.3GW	1GW	3GW	5GW	0.3GW	1GW	3GW	5GW	0.3GW	1GW	3GW	5GW
1.0	41%	0.12	0.41	1.23	2.05	13.9	46.3	139.0	231.7	46.3	46.3	46.3	46.3
2.0	56%	0.17	0.56	1.68	2.8	19.0	63.3	189.8	316.4	63.3	63.3	63.3	63.3
4.0	75%	0.23	0.75	2.25	3.75	25.4	84.8	254.3	423.8	84.8	84.8	84.8	84.8
8.0	90%	0.27	0.90	2.70	4.5	30.5	101.7	305.1	508.5	101.7	101.7	101.7	101.7

### Revenue Requirements for Energy Storage

The revenue requirement represents the annualized costs to own and operate the energy storage unit, inclusive of a return on investment. Next, we present the revenue requirements in (\$/kWyr) for each storage configuration using assumptions consistent with both 2019 and 2030 values in Chapter 4. The revenue requirements for each configuration are presented in Table 6.5.5. Once more we note that as higher is the size of the storage device the higher is the RR (in \$M/year). Also, they vary per technology, e.g., a lithium-ion battery with 3 GW of power and 2 hours of duration (LI-3GW/6GWh) has a RR of \$178M/year, considering 2019 costs, while a flow battery with similar power/duration configuration has a RR of \$667.5M/year. As there are significant price declines for lithium-ion batteries, we consider the RR associated with 2019 and projected 2030 costs. For other technologies, only the RR computed using 2019 costs are used.



**Table 6.5.5.** Revenue requirements for each energy storage technology considered

Energy Storage Technology Configuration	RR 2019 (\$M/year)	RR 2019 (\$/kWyr)	RR 2030 (M\$/year)	RR 2030 (\$/kWyr)
LI-0.3GW/0.3GWh	49.3	164.4	23.2	77.5
LI-0.3GW/0.6GWh	53.4	178.0	25.8	85.9
LI-0.3GW/1.2GWh	79.9	266.4	43.4	144.7
LI-1GW/1GWh	164.4	164.4	77.5	77.5
LI-1GW/2GWh	178.0	178.0	85.9	85.9
LI-1GW/4GWh	266.4	266.4	144.7	144.7
LI-3GW/3GWh	493.2	164.4	232.4	77.5
LI-3GW/6GWh	534.0	178.0	257.6	85.9
LI-3GW/12GWh	799.1	266.4	434.1	144.7
LI-5GW/5GWh	822.1	164.4	387.3	77.5
LI-5GW/10GWh	889.9	178.0	429.3	85.9
LI-5GW/20GWh	1331.9	266.4	723.5	144.7
FB-0.3GW/0.6GWh	66.8	222.5	-	-
FB-1GW/2GWh	222.5	222.5	-	-
FB-3GW/6GWh	667.5	222.5	-	-
FB-5GW/10GWh	1112.5	222.5	-	-
PSH-0.3GW/2.4GWh	44.2	147.2	-	-
PSH-1GW/8GWh	147.2	147.2	-	-
PSH-3GW/24GWh	441.6	147.2	-	-
PSH-5GW/40GWh	736.0	147.2	-	-
CAES-0.3GW/2.4GWh	28.7	95.5	-	-
CAES-1GW/8GWh	95.5	95.5	-	-
CAES-3GW/24GWh	286.5	95.5	-	-
CAES-5GW/40GWh	477.5	95.5	-	-

### Energy Benefits of Storage

Computing the difference between the total operational dispatch costs in each scenario provides an estimate of the energy benefits associated with the addition of storage devices. We compute the energy benefits for each operational model run, with the results reported in Table 6.5.6. Energy storage is only utilized in a manner that decreases system costs. Therefore, we observe energy benefits for every storage device configuration. We also report the energy benefits (in \$/kWyr), obtained by dividing the energy benefits in (\$M/year) by the power capacity of the battery in GW. Similar results for the other scenarios can be found in the Appendix B.

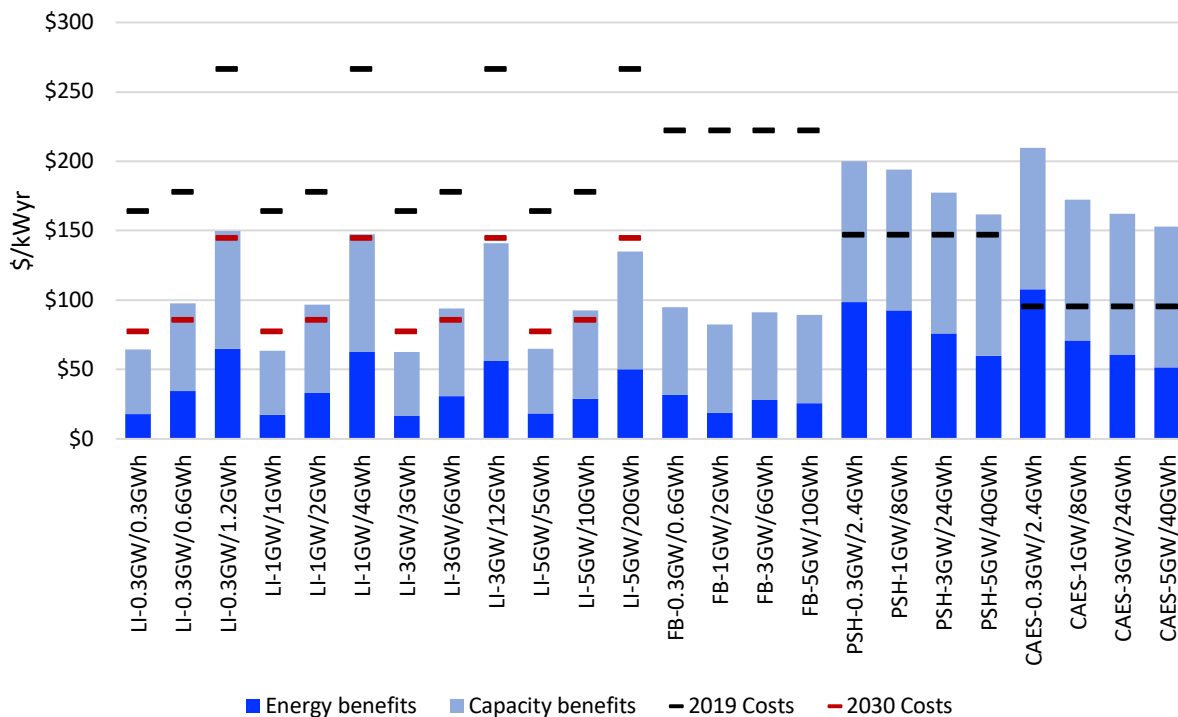
**Table 6.5.6.** Operational dispatch costs and energy benefits in the base case

Analysis Scenario	Operational Dispatch Simulation Case	Operational Dispatch Total Costs (\$M/year)	Energy Benefits (\$M/year)	Energy Benefits (\$/kWyr)
	S01: NS	\$12,004.7	-	-
	S01: LI-0.3GW/0.3GWh	\$11,999.2	\$5.4	\$18.1
	S01: LI-0.3GW/0.6GWh	\$11,994.3	\$10.4	\$34.5
	S01: LI-0.3GW/1.2GWh	\$11,985.1	\$19.5	\$65.1
	S01: LI-1GW/1GWh	\$11,987.3	\$17.3	\$17.3
	S01: LI-1GW/2GWh	\$11,971.4	\$33.3	\$33.3
	S01: LI-1GW/4GWh	\$11,942.1	\$62.6	\$62.6
	S01: LI-3GW/3GWh	\$11,955.7	\$49.0	\$16.3
	S01: LI-3GW/6GWh	\$11,912.0	\$92.7	\$30.9
	S01: LI-3GW/12GWh	\$11,835.6	\$169.0	\$56.3
	S01: LI-5GW/5GWh	\$11,912.4	\$92.3	\$18.5
	S01: LI-5GW/10GWh	\$11,859.4	\$145.3	\$29.1
	S01: LI-5GW/20GWh	\$11,753.8	\$250.9	\$50.2
	S01: FB-0.3GW/0.3GWh	\$11,999.9	\$4.8	\$15.9
	S01: FB-0.3GW/0.6GWh	\$11,995.2	\$9.4	\$31.5
	S01: FB-0.3GW/1.2GWh	\$11,986.5	\$18.1	\$60.5
Base Case	S01: FB-1GW/1GWh	\$11,989.5	\$15.1	\$15.1
	S01: FB-1GW/2GWh	\$11,985.6	\$19.0	\$19.0
	S01: FB-1GW/4GWh	\$11,946.7	\$58.0	\$58.0
	S01: FB-3GW/3GWh	\$11,962.4	\$42.3	\$14.1
	S01: FB-3GW/6GWh	\$11,921.3	\$83.4	\$27.8
	S01: FB-3GW/12GWh	\$11,850.4	\$154.2	\$51.4
	S01: FB-5GW/5GWh	\$11,937.3	\$67.3	\$13.5
	S01: FB-5GW/10GWh	\$11,875.1	\$129.6	\$25.9
	S01: FB-5GW/20GWh	\$11,779.9	\$224.8	\$45.0
	S01: PSH-0.3GW/2.4GWh	\$11,975.1	\$29.5	\$98.4
	S01: PSH-1GW/8GWh	\$11,912.2	\$92.5	\$92.5
	S01: PSH-3GW/24GWh	\$11,777.4	\$227.2	\$75.7
	S01: PSH-5GW/40GWh	\$11,705.3	\$299.4	\$59.9
	S01: CAES-0.3GW/2.4GWh	\$11,972.3	\$32.4	\$107.8
	S01: CAES-1GW/8GWh	\$11,933.9	\$70.8	\$70.8
	S01: CAES-3GW/24GWh	\$11,823.1	\$181.5	\$60.5
	S01: CAES-5GW/40GWh	\$11,747.3	\$257.4	\$51.5

### Net Benefit Results

We compare the total benefits by adding the capacity benefits (Table 6.5.4) and the energy benefits (Table 6.5.6 and from Appendix B Tables 1B to 5B) for each storage technology with the total revenue requirements from Table 6.5.5. We note that most of the cases utilizing the 2019 costs the revenue requirements are not fully recovered through energy and capacity benefits, except the cases of PSH and CAES. Using 2030 assumptions for Li-ion costs, however, we observe that most of the configurations yield benefits that approach or exceed cost parity.

Figure 6.5.9 presents the benefits and costs for different configurations under the Base scenario. Figures 6.5.10 - 6.5.15 represent similar analysis considering the different scenarios: Duke IRP, Extended REPS, Clean Energy Standard, Carbon Cap, High Natural Gas Prices, and Electric Vehicles Deployment, respectively. We note that the runs considering flow batteries (FB) with 1- and 4-hour duration are omitted in these figures to enhance readability. However, the net benefits for these storage configurations are presented later in this section.



**Figure 6.5.9.** Benefits and costs for different storage configurations in the Base scenario. For each technology configuration, energy and capacity benefits are stacked, and compared with the associated revenue requirement(s).

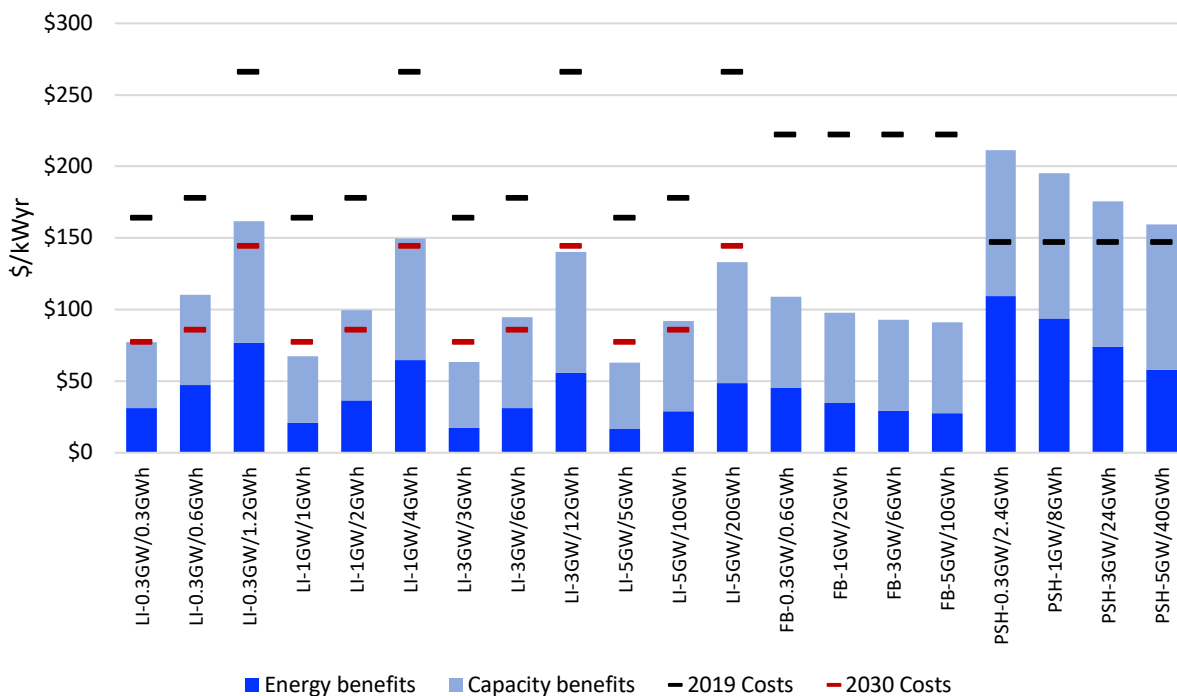


Figure 6.5.10. Benefits and costs for different configurations in the Duke IRP scenario

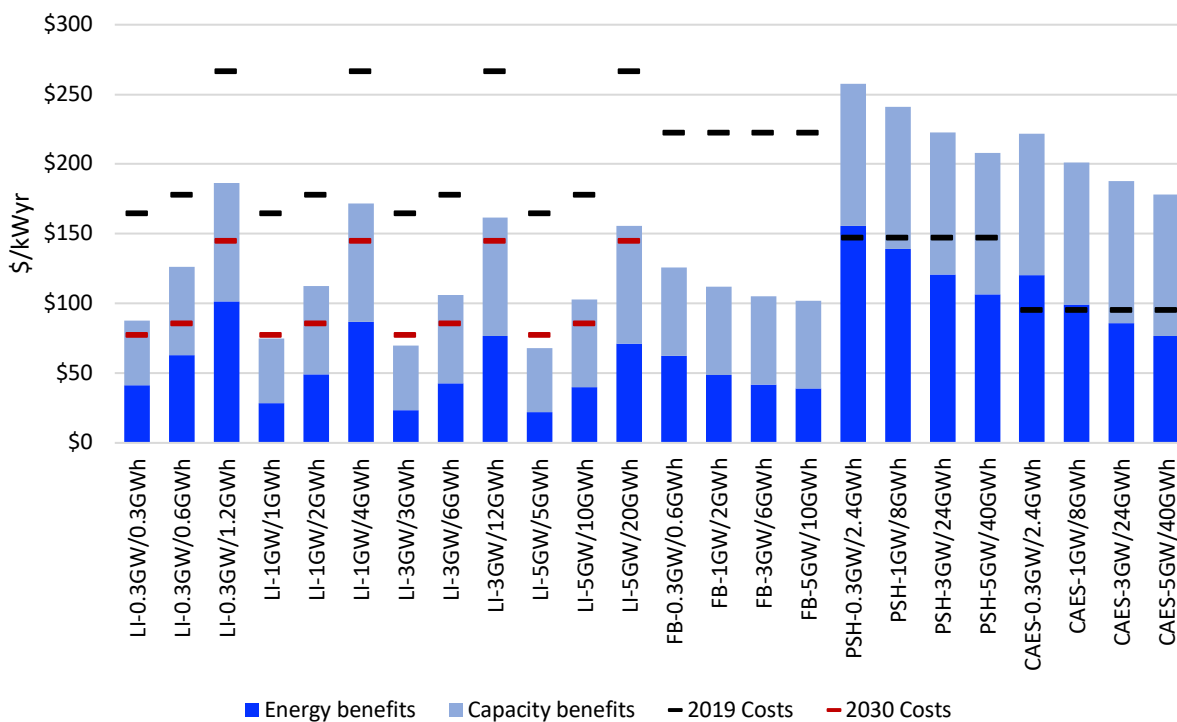


Figure 6.5.11. Benefits and costs for different storage configurations in the Extended REPS scenario

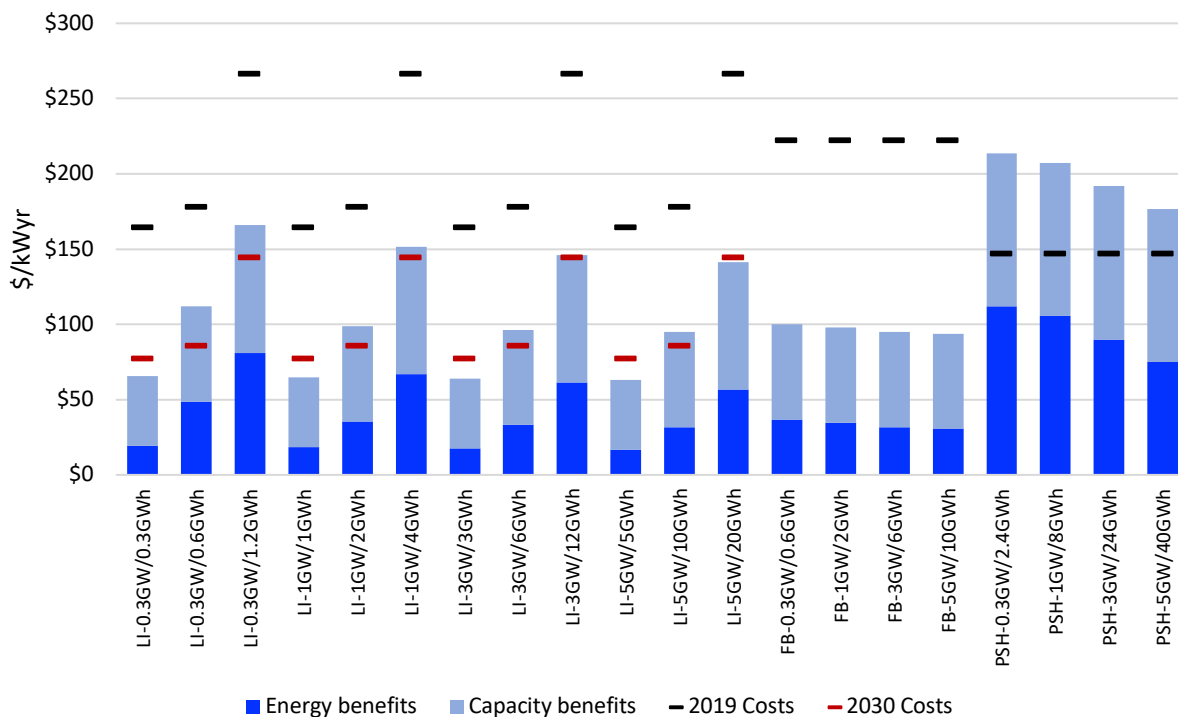


Figure 6.5.12. Benefits and costs for different configurations in the Clean Energy Standard scenario

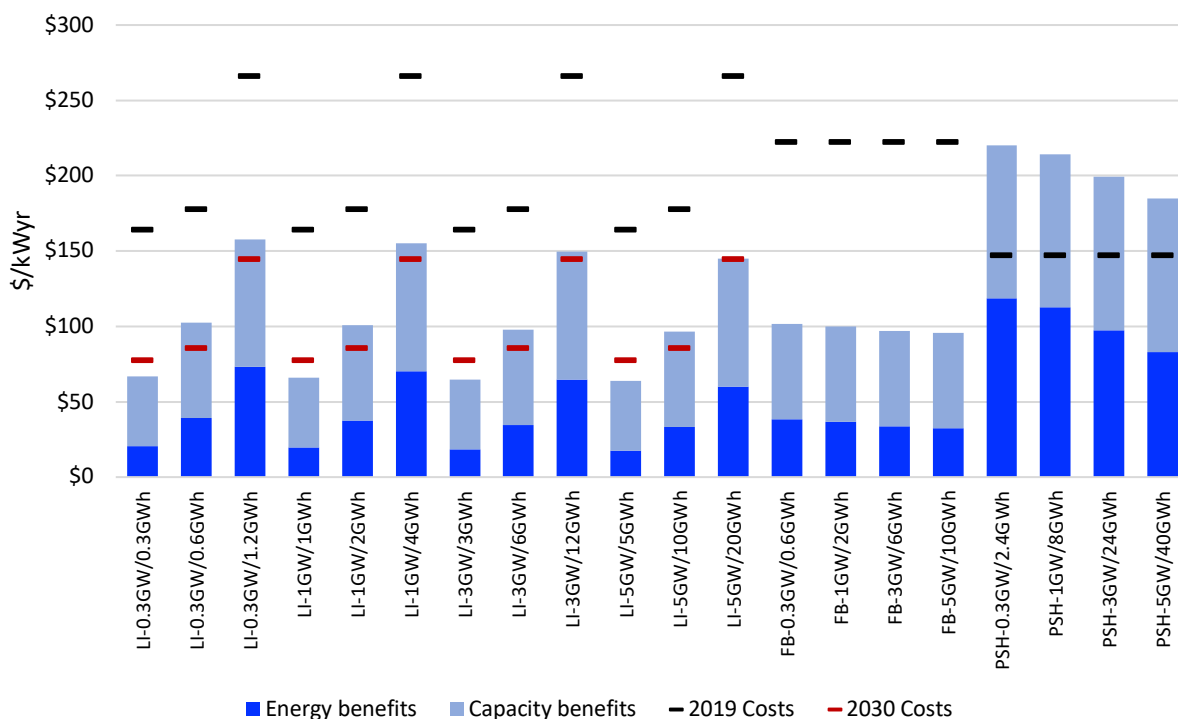


Figure 6.5.13. Benefits and costs for different configurations in the Carbon Cap scenario.

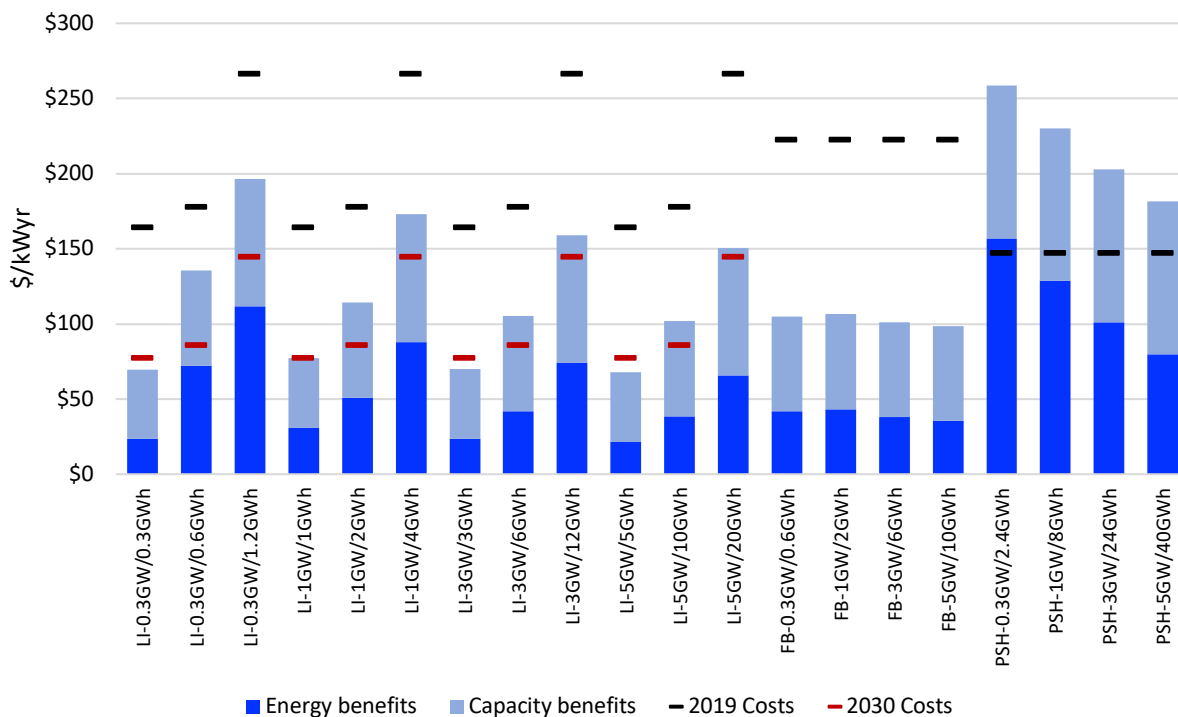


Figure 6.5.14. Benefits and costs for different configurations in the High Natural Gas Price scenario.

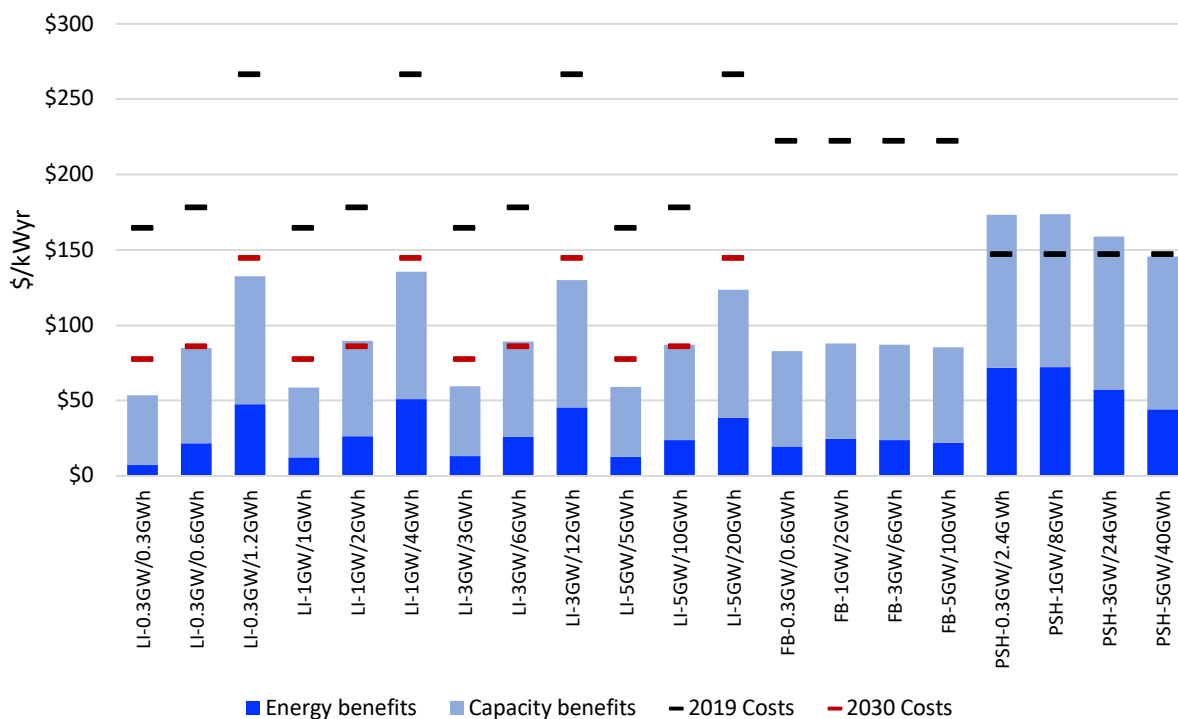


Figure 6.5.15. Benefits and costs for different configurations in the Electric Vehicle Deployment scenario.

Once the energy and capacity benefits are computed for each storage configuration, we calculate the total net benefits associated with storage deployment using (3). Tables 6.5.7 and 6.5.8 present the total net benefits in (\$/kWyr) for each configuration of storage devices considered in the analysis.

From the net benefits results presented in Table 6.5.7, we observe that Li-ion batteries are more cost competitive than flow batteries using 2019 costs. Li-ion batteries do not show positive net economic benefits using 2019 costs under any of the scenarios and configurations considered. However, when considering the projected 2030 costs, many scenarios and configurations with lithium-ion batteries exceed cost parity, providing positive net benefits to the power system. For example, in the Base scenario, the Li-ion configuration with highest net benefit (0.3 GW of capacity and 2-hour duration) shows a positive net benefit of \$12/kWyr. Under scenarios with higher solar penetration, or with higher natural gas prices, the net benefits increase. For example, in the Expanded REPS case, the net benefits reach \$42/kWyr. As more solar generation comes online, and solar curtailment and integration become more pressing challenges, storage can play a larger role by optimizing the use of solar generation and reducing the overall costs. Throughout many of our scenarios, by 2030, we find that Li-ion batteries can be cost-effective at much higher capacities (e.g., 5 GW of storage) and at longer durations (e.g., 4 hours).

**Table 6.5.7.** Total net benefits (\$/kWyr) from lithium-ion and flow batteries for bulk energy time shifting and peak capacity deferral

	duration (h)	LI (2019)				LI (2030)				FB			
		0.3GW	1GW	3GW	5GW	0.3GW	1GW	3GW	5GW	0.3GW	1GW	3GW	5GW
Base Case	1	-100	-101	-102	-100	-13	-14	-15	-13	-104	-104	-105	-106
	2	-80	-81	-84	-86	12	11	8	6	-128	-140	-131	-133
	4	-117	-119	-125	-131	5	3	-4	-10	-191	-193	-200	-206
Duke IRP	1	-87	-97	-101	-101	0	-10	-14	-14	-89	-99	-103	-104
	2	-67	-78	-83	-86	25	14	9	6	-114	-124	-130	-132
	4	-105	-117	-126	-133	17	5	-4	-11	-177	-190	-199	-207
Expanded REPS	1	-77	-90	-95	-96	10	-3	-8	-9	-78	-91	-96	-98
	2	-52	-65	-72	-75	41	27	20	17	-97	-110	-117	-120
	4	-80	-95	-105	-111	42	27	17	11	-151	-166	-176	-182
Clean Energy Standard	1	-99	-99	-101	-101	-12	-12	-14	-14	-99	-98	-101	-103
	2	-66	-79	-82	-83	26	13	11	9	-122	-125	-127	-129
	4	-100	-115	-120	-125	21	7	2	-3	-183	-187	-193	-198
Carbon Cap	1	-97	-98	-100	-100	-10	-11	-13	-13	-99	-100	-102	-102
	2	-75	-77	-80	-82	17	15	12	11	-121	-123	-126	-127
	4	-109	-111	-117	-122	13	10	5	0	-180	-183	-189	-194
High Natural Gas Price	1	-95	-87	-95	-97	-8	0	-8	-10	-98	-95	-97	-100
	2	-42	-64	-73	-76	50	28	19	16	-118	-116	-121	-124
	4	-70	-94	-107	-116	52	28	14	6	-172	-173	-183	-192
Electric Vehicles	1	-111	-106	-105	-105	-24	-19	-18	-18	-113	-108	-107	-107
	2	-93	-88	-89	-91	-1	4	4	1	-139	-135	-136	-137
	4	-134	-131	-136	-143	-12	-9	-14	-21	-207	-204	-209	-216

**Table 6.5.8.** Total net benefits (\$/kWyr) from pumped storage hydro and compressed air energy storage for bulk energy time shifting and peak capacity deferral

	duration (h)	PSH				CAES			
		0.3GW	1GW	3GW	5GW	0.3GW	1GW	3GW	5GW
Base Case	8	53	47	30	14	114	77	67	58
Duke IRP	8	64	48	29	12	-	-	-	-
Expanded REPS	8	110	94	75	61	126	106	92	83
Clean Energy Standard	8	67	60	45	30	-	-	-	-
Carbon Cap	8	73	67	52	38	-	-	-	-
High Natural Gas Price	8	111	83	56	34	-	-	-	-
Electric Vehicles	8	26	27	12	-1	-	-	-	-

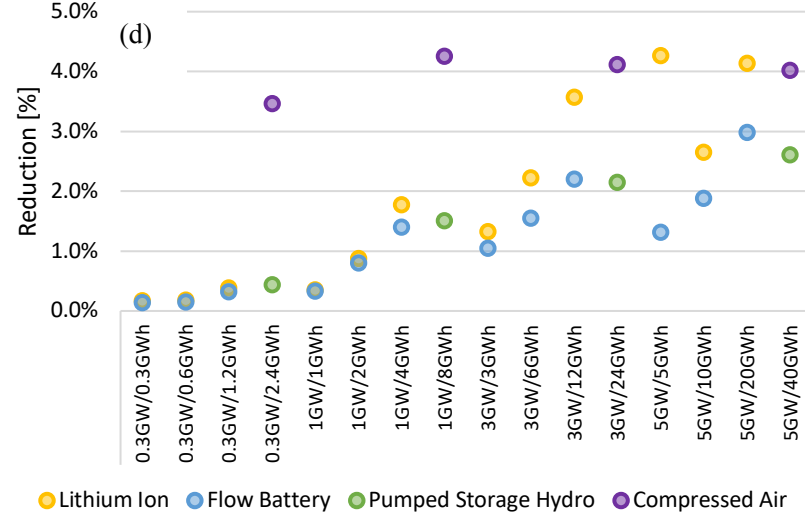
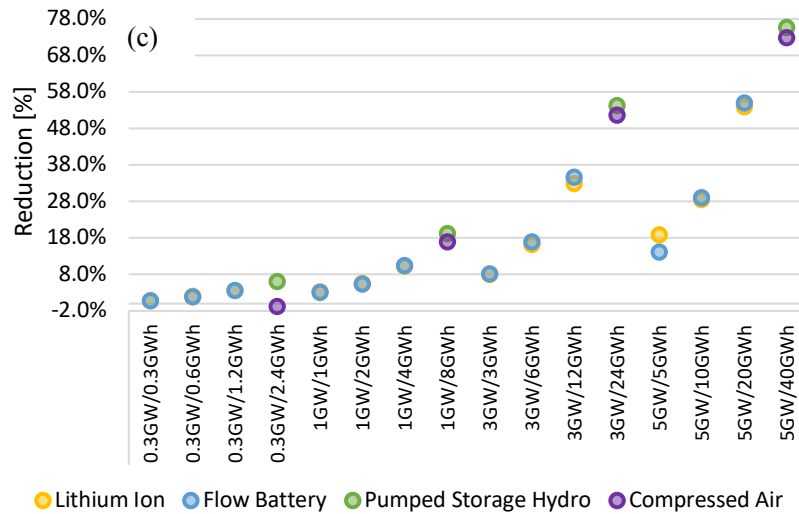
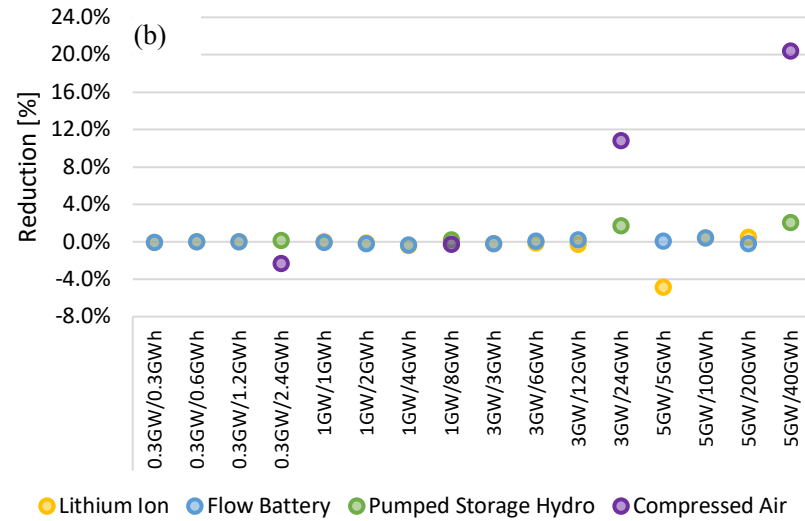
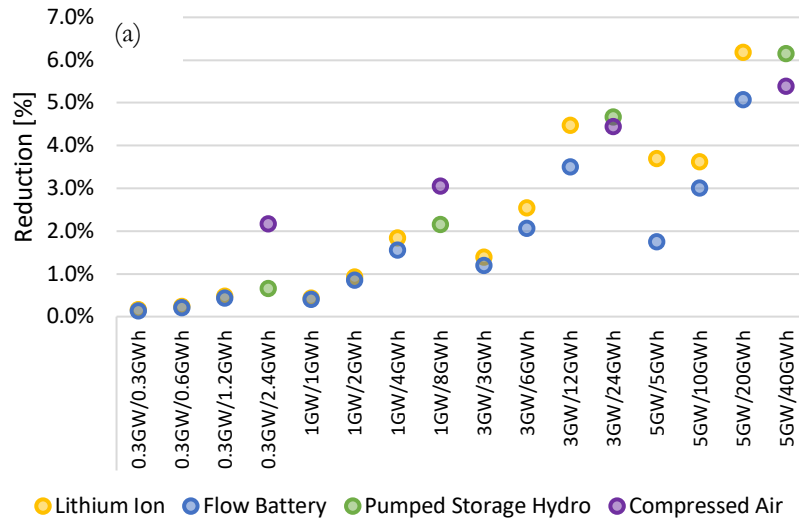
The economic results for pumped hydro and CAES produce larger net benefits than Li-ion batteries. For these two technologies, the 8-hour duration has a higher capacity credit (90%) and produces higher revenues. In our analysis, CAES with 8-hour duration produced the highest net benefit among all the other technologies and configurations considered for the Base and Expanded REPS scenarios. For example, in the Base Case, CAES-0.3GW/2.4GWh yielded a net benefit of \$114/kWyr. Pumped storage hydro also proved to be economically attractive, with net benefits of \$53/kWyr for the 0.3 GW/2.4 GWh configuration in the Base case. Moreover, pumped hydro and CAES exhibit even higher benefits in the Extended REPS scenario, reaching \$110/kWyr and \$126/kWyr, respectively. Pumped storage also exhibits large benefits in the High Natural Gas Price scenario, reaching \$111/kWyr considering PSH-0.3GW/2.4GWh a configuration.

However, while our analysis shows that pumped hydro and CAES may be economically attractive under a way range of scenarios, it is important to note that these technologies have highly site-specific costs.

### Energy Storage Impacts on CO<sub>2</sub> Emissions

We analyze emission reductions in two scenarios (Base and Expanded REPS) with different technology configurations, and found that the addition of energy storage reduced system-wide CO<sub>2</sub> emissions when used for bulk energy time shifting and peak capacity deferral. Figure 6.5.16 shows the relative reduction in system-wide CO<sub>2</sub> emissions for the various technology configurations under Base Case assumptions, ranging from net reductions of 0.17% to 9.3% of emissions. In general, we see that increasing the capacity and duration of energy storage leads to a greater reduction in CO<sub>2</sub> emissions. We find that natural gas combustion turbines show the greatest reduction in generation when energy storage is introduced, decreasing up to 78.5%. Combined-cycle natural gas and coal generation also exhibit reduced utilization when storage is deployed.





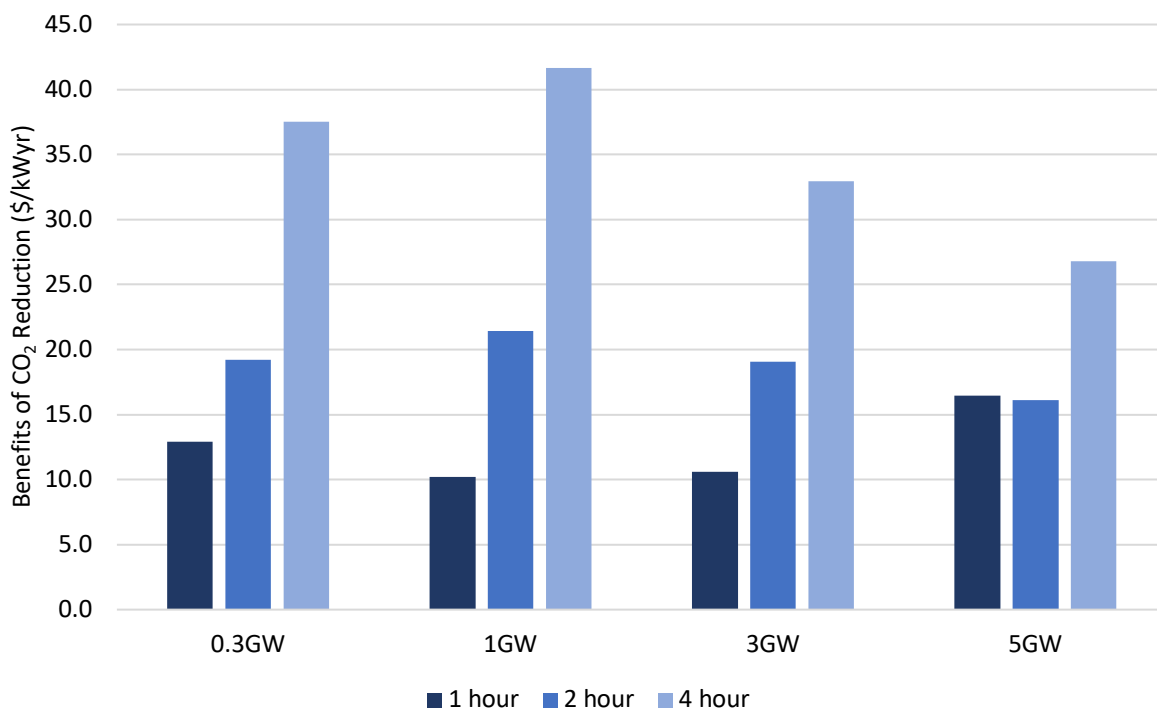
**Figure 6.5.16.** CO<sub>2</sub> reduction as well as changes in natural gas and coal plant generation levels, by storage technology type, installed capacity, and duration. (a) Reduction in CO<sub>2</sub> emissions; (b) change in natural gas combined-cycle generation; (c) change in natural gas combustion turbine generation; (d) change in coal steam generation. All changes are with respect to the Base scenario without storage.

We also calculate the normalized annual emissions per kW of battery capacity. Normalized to the size of the Li-ion battery, we find emissions reductions ranging from 0.2 metric tons of CO<sub>2</sub>/kWyr to 0.8 metric tons of CO<sub>2</sub>/kWyr in our Base scenario (Table 6.5.9). For the Expanded REPS scenario, emission results are presented in Appendix B.

**Table 6.5.9.** Normalized reductions in CO<sub>2</sub> emissions in metric tons of CO<sub>2</sub>/kWyr

duration (h)	LI (2030)			
	0.3GW	1GW	3GW	5GW
1	0.26	0.20	0.21	0.33
2	0.38	0.43	0.38	0.32
4	0.75	0.83	0.66	0.54

In North Carolina, there is not an explicit cost associated with CO<sub>2</sub> emissions. In some parts of the U.S., cap and trade programs lead to direct costs associated with these emissions. If one assumed a cost of \$50 per metric ton of CO<sub>2</sub>, which is consistent with the 2030 value for the social cost of carbon under a 3% discount rate (U.S Environmental Protection Agency, 2016), the benefits from Li-ion batteries would increase by values between \$10 and \$40/kWyr (Figure 6.5.17).



**Figure 6.5.17.** Benefits of CO<sub>2</sub> emissions reduction for Li-ion batteries with different configurations in the Base scenario. Carbon Benefits of CO<sub>2</sub> reductions (valued at \$50/t CO<sub>2</sub>) in \$/kWyr.

### 6.5.5 Conclusions

Through our capacity expansion and economic dispatch modeling, we are able to make several important observations about the viability of energy storage for bulk energy time shifting and peak capacity deferral in North Carolina. We find that pumped storage hydro and compressed air energy storage may be cost-effective today, but are limited by siting constraints. We also observe that Li-ion batteries are not cost-effective for these applications in 2019, but are expected to become cost-effective in advance of 2030 cost projections.

Across technologies, we find that 5 GW of storage may be cost-effective for time shifting and peak shaving. A very important driver for energy storage is the capacity value and the technology's ability to displace new generation investments. We observe that high natural gas prices and increased solar penetration levels increase the benefits of energy storage. Across the scenarios where emissions were analyzed, we see that the introduction of energy storage decreases system-wide CO<sub>2</sub> emissions, predominately by displacing natural gas peaking generation.

### References

- CleanTechnica, (2018) What are the most efficient Electric cars?, available at: <https://cleantechnica.com/2018/06/30/what-are-the-most-efficient-electric-cars/>
- EIA, (2018a) Annual Energy Outlook, available at: <https://www.eia.gov/outlooks/aeo/>
- EIA, (2018b) U.S. Electric System Operating Data tool, available at: [https://www.eia.gov/realtime\\_grid/#/status?end=20181027T21](https://www.eia.gov/realtime_grid/#/status?end=20181027T21)
- EIA, (2018c) Form: Annual Electric Generator Data (EIA-860), available at: <https://www.eia.gov/electricity/data/eia860/>
- EIA, (2018d) Form: Electric Utility Data Survey (EIA-923), available at: <https://www.eia.gov/electricity/data/eia923/>
- Eshraghi, H., de Queiroz, A. R., & DeCarolis, J. F. (2018). US Energy-Related Greenhouse Gas Emissions in the Absence of Federal Climate Policy. *Environmental science & technology*, 52(17), 9595-9604.
- Joseph, A., and Shahidehpour, M. (2006). Battery storage systems in electric power systems. In *Power Engineering Society General Meeting, 2006. IEEE* (pp. 8-pp).
- Muratori, M. (2018). Impact of uncoordinated plug-in electric vehicle charging on residential power demand. *Nature Energy*, 3(3), 193. Data source available at: <https://catalog.data.gov/dataset/impact-of-uncoordinated-plug-in-electric-vehicle-charging-on-residential-power-demand-supp-31006>
- Newell, S. et al (2018) PJM Cost of New Entry Combustion Turbines and Combined-Cycle Plants with June 1, 2022 Online Date. The Brattle Group and Sargent & Lundy.

NREL, (2018) Annual Technology Baseline (ATB), National Renewable Energy Laboratory, available at: <https://atb.nrel.gov>

Roberts, B. P., & Sandberg, C. (2011). The role of energy storage in development of smart grids. Proceedings of the IEEE, 99(6), 1139-1144.

IEA - International Energy Agency, (2004) Documentation for the MARKAL Family of Models.: Energy Technology Systems Analysis Programme, available at: <http://www.etsap.org/documentation.asp>

IIASA - International Institute for Applied Systems Analysis, (2011) Energy Modeling Framework: Model for Energy Supply Strategy Alternatives and their General Environmental Impact (MESSAGE), <http://www.iiasa.ac.at/Research/ENE/model/message.html>.

Howells M. et al.; (2011) OSeMOSYS: the open source energy modeling system: an introduction to its ethos, structure and development. Energy Policy, 39:5850–70. DOI: 10.1016/j.enpol.2011.06.033.

Hunter, K., Sreepathi, S., DeCarolis J. F., (2013) Modeling for Insight Using Tools for Energy Model Optimization and Analysis (Temoa), Energy Economics, 40, 339-349, DOI: 10.1016/j.eneco.2013.07.014.

Sioshansi, R., Madaeni, S. H., & Denholm, P. (2014). A dynamic programming approach to estimate the capacity value of energy storage. IEEE Transactions on Power Systems, 29(1), 395-403.

US DOT, (2016) Highway Statistics, Policy and Governmental Affairs – Office of Policy Information, available at: <https://www.fhwa.dot.gov/policyinformation/statistics/2016/>

U.S. Environmental Protection Agency, (2016). Technical Support Document: Technical Update of the Social Cost of Carbon for Regulatory Impact Analysis Under Executive Order 12866.

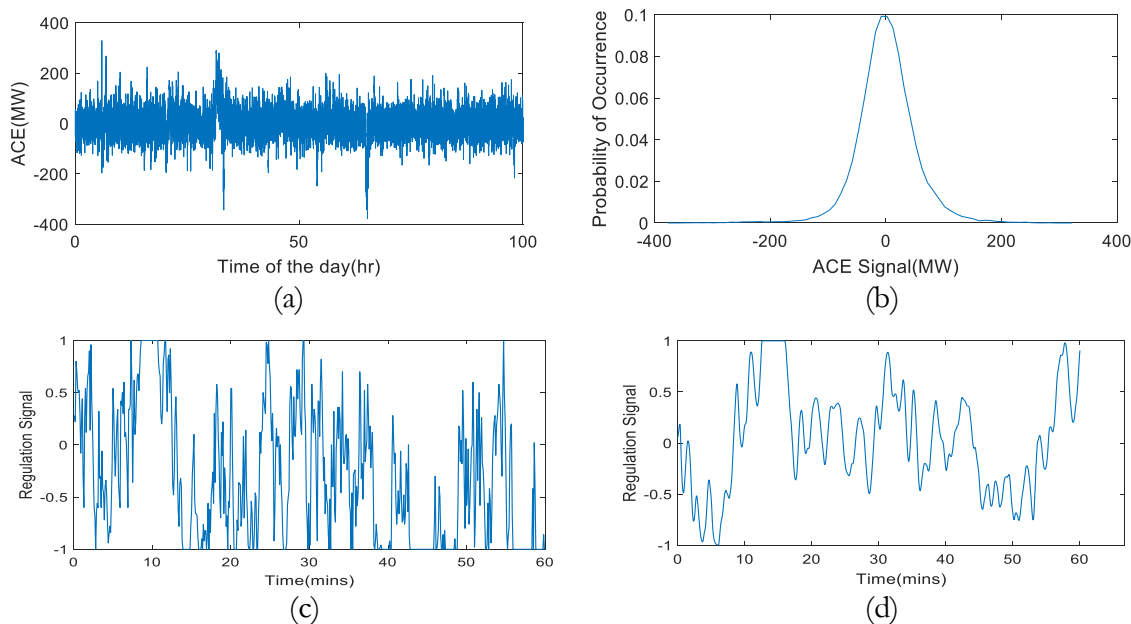
## 6.6. Frequency Regulation

In this part of the study, we investigate the performance and economics of using energy storage systems (ESS) to provide frequency regulation services.

### 6.6.1 Frequency Regulation Services

The operation of the electric power system needs to maintain a continuous balance between generation and load. Frequency regulation is an important component of operating reserves used to maintain this balance. When load increases or decreases suddenly, system frequency will decrease or increase. The rate of frequency change depends on system inertia. During such a change, generator governors respond and adjust the generation to match the load changes in order to bring the system frequency to a new equilibrium point.

To restore the system frequency to its nominal value (i.e., 60 Hz in the U.S.) and to maintain tie-line power flows between different control areas at scheduled values, frequency regulation is performed, consisting of small increases (i.e., regulation up) and decreases (i.e., regulation down) in power output by participating resources (Leitermann, 2012). In general, the frequency regulation signal is generated from a designed controller with the Area Control Error (ACE) as the controller input and usually updated every 2-10 seconds. Figure 6.6.1 provides an example of ACE signals in NY-ISO, its corresponding probability density function (PDF) over one week, the NY-ISO regulation signal, and PJM RegD signal.



**Figure 6.6.1.** Illustrative data related to frequency regulation. (a) The NY-ISO ACE signal (June, 2017); (b) corresponding PDF of NY-ISO ACE over one week; (c) one hour NY-ISO regulation signal; and (d) one hour PJM RegD signal (PJM, 2018; NYISO, 2018).

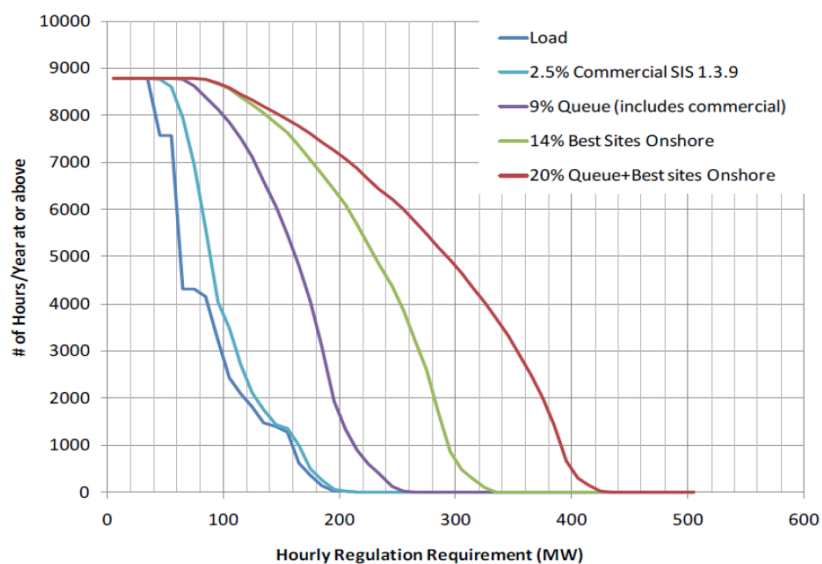
Derived from ACE signals, regulation signals usually bear the same characteristics as the ACE signals. As shown in Figure 6.6.1b, although the mean value of the ACE signal is very close to zero, it can have a large bias over a given period of time (e.g., between hours 25 and 30 in Figure 6.6.1a).

The regulation signals are always proportionally scaled with respect to the capacity of participating units, which are in the range of [-1,1] as shown in Figure 6.6.1c-d.

The main reasons for performing regulation are to maintain the grid frequency and to comply with the North American Electric Reliability Council (NERC) Control Performance Standards 1 and 2 (CPS1 and CPS2) (NERC, 2008). These two standards require the minimum control level for ACE in each control area so that areas manage their own load changes. CPS1 requires that the ACE for a control area be in the direction to bring the frequency back towards its scheduled value, at least a certain fraction of the time. CPS2 limits the average value of ACE over each 10-minute period for each area, to ensure that the total load-generation imbalance for the area does not tend to be too large in magnitude.

### 6.6.2 Need for Fast Frequency Services Provided by Energy Storage Systems

When the amount of renewable generation increases, the need for regulation and load following services will increase. In December 2010, ISO-NE released the final report of its New England Wind Integration Study (ISO-NE, 2010). The study assessed a number of growth scenarios for wind in New England up to year 2020, and the potential impacts on the ISO-NE power grid. As shown in Figure 6.6.2, the study identified a need for an increase in the regulation requirement even in the lowest wind penetration scenario (2.5% wind energy), and the requirement would have noticeable increases for higher penetration levels. For example, the regulation requirement increases to 161 MW in the 9% wind energy scenario (about 4000 MW of wind), and to as high as 313 MW in the 20% scenario (8000-10000 MW).

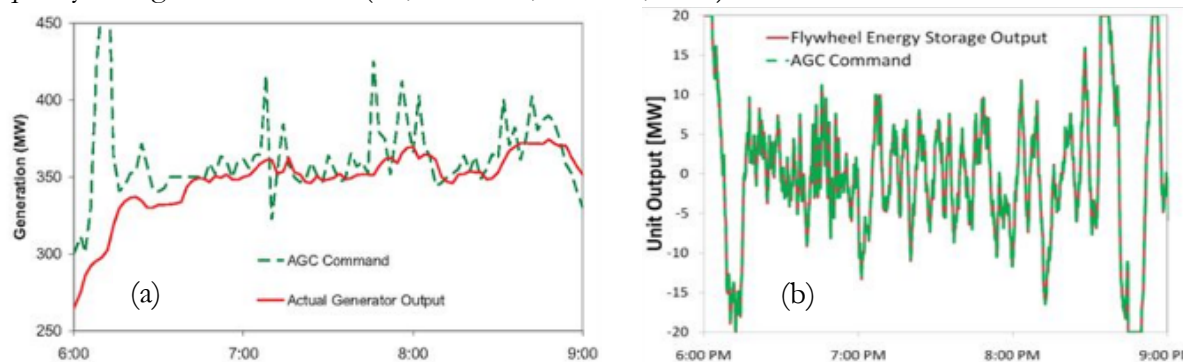


**Figure 6.6.2.** Duration curves of estimated hourly regulation requirements for load and selected wind scenarios.

Traditionally, regulation services are provided by generators. Providing regulation services reduces generator lifetime because of the significant wear-and-tear caused by fast ramping up and down. In power grids with high penetrations of intermittent renewable generation, both the magnitude and speed of the variations in the regulation signal are high, producing even higher wear-and-tear on the regulation units. In addition, because of the limited ramping capabilities, the response rates of

conventional regulation generators are slow, as shown in Figure 6.6.3a. Thus, to meet regulation requirements, more regulation capacity is required to compensate the control errors.

To create incentives for fast responding resources to participate in regulation services, the Federal Energy Regulatory Commission (FERC, 2011) enacted FERC Order 755, which requires system operators to add a performance payment with an accuracy adjustment to the capacity payment typically used in markets for ancillary services. All ISO/RTOs have implemented this pay-for-performance regulation market. Under this new market rule, the participating resource will be rewarded by what it declares (i.e., regulation capacity) and what it supplies (i.e., regulation mileage). Those regulatory advancements make providing fast regulation service a high-value ancillary service, and also make energy storage a suitable candidate for providing it. Compared with generator units, an energy storage controlled by power electronics has a fast response rate that can follow the regulation signals closely, as shown in Figure 6.6.3b, where the AGC command (i.e., generator control scheme) is similar to the regulation signal, derived from ACE (NERC, 2011). There are three main advantages of using energy storage for regulation services: it reduces the wear-and-tear on conventional generators, reduces the amount of required regulation capacity, and improves the quality of regulation services (Lu, Makarov, Weimar, 2010).



**Figure 6.6.3.** (a) Regulation service provided by a conventional generator, and (b) regulation service provided by energy storage (Massachusetts Energy Storage Initiative, 2017).

In the past few years, the share of energy storage in regulation markets has increased rapidly (FERC, 2013). For example, in the PJM market, the storage capacity has increased from zero in 2005 to over 280 MW in 2017, making up 41% of its regulation procurement capacity (Massachusetts Energy Storage Initiative, 2017). Since enabling the use of storage in its market, PJM has been able to reduce the size of its regulation market by 30%, resulting in significant savings for ratepayers.

To guide the deployment of storage, it is crucial to quantify the storage performance and cost-effectiveness when responding to different types of regulation signals. To help storage manufacturers and service providers improve performance and reduce service costs, it is critical to identify storage characteristics that have the biggest influence on response rate and lifetime depreciation.

In this study, we perform benefit-cost analysis of storage-based regulation services. High and low cost parameters of storage are used to derive the upper- and lower- bounds of cost-of-service. The impact of storage lifetime depreciation and storage-friendly regulation signal design on storage lifetime depreciation, service quality, and cost-of-service are quantified. Two storage operation mechanisms are considered in this study: 1-directional and 2-directional. When providing 1-

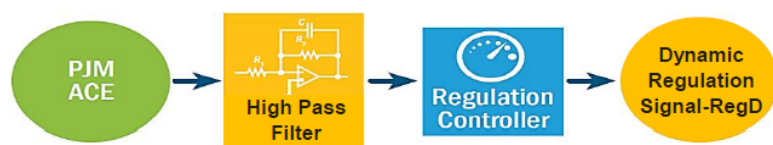
directional service, the storage unit responds only to the regulation-up or regulation-down service during the committed period. Providing 1-directional service is an option for charging-only loads (e.g., electric vehicles without vehicle-to-grid functions). When providing 2-directional service, the storage unit responds to both regulation-up and regulation-down signals. In this analysis, we focus on two storage technologies, lithium-ion batteries and flywheels, which both have fast ramping rates and can provide the regulation service. Regulation signals and the corresponding regulation service prices published by the New York Independent System Operator (NYISO) and PJM are used to conduct the study. We requested the frequency regulation signal and the area control area for Duke Energy, but it was deemed “business confidential” information and was thus not shared with the study team.

### 6.6.3 Modeling Methods

This section describes the regulation signals and service payment mechanism, introduces the energy storage model as well as lifetime estimation method, and describes benefit-cost calculations.

#### Regulation signals

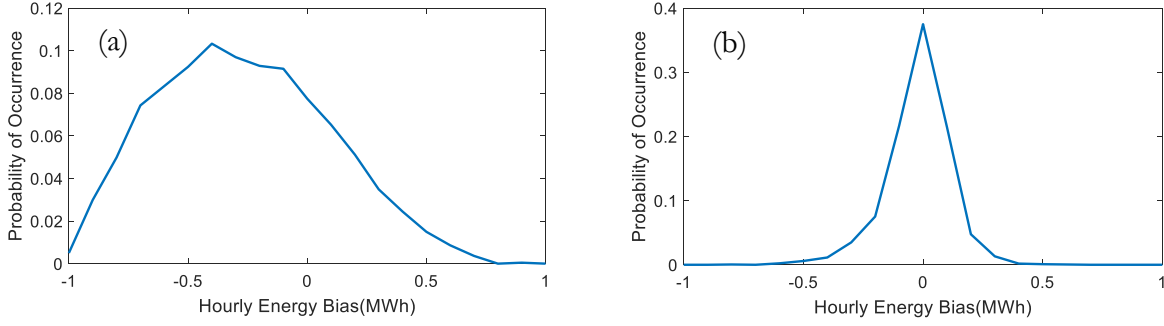
ACE signals often have some DC component, so they are not energy-neutral. This can cause an energy storage system with limited energy storage capabilities to be fully charged or discharged after providing regulation services over a period of time. Thus, ISOs such as PJM and ISO-NE have designed an energy-neutral regulation signal to facilitate the provision of regulation services by storage (Xu et al., 2016). For example, in PJM, regulation signals have been split into two signals: slow-responding Regulation A (RegA) and fast-responding Regulation D (RegD, where the D stands for “dynamic”) (PJM, 2018). The RegD signal is generated by applying the original PJM area control error (ACE) signal to a high pass filter, as shown in Figure 6.6.4. In this configuration of the split-signal system, RegA was designed for resources “with the ability to sustain energy output for long periods of time, but with limited ramp rates”, while RegD was designed for resources “with the ability to quickly adjust energy output, but with limited ability to sustain energy output for long periods of time” (Kleinman Center for Energy Policy, 2017).



**Figure 6.6.4.** Design of fast regulation signal (PJM, 2016).

As shown in Figure 6.6.5, the hourly energy bias of 1MW units responding to PJM-RegD is very close to zero while PJM-RegA has a DC bias. The PJM example demonstrates that if regulation signals are carefully designed, the disadvantage of using energy storage can be avoided. By letting energy storage devices supply the fast changing component of the regulation signal, the generator units are allowed to move slower and less, reducing their wear-and-tear while improving the regulation service quality.





**Figure 6.6.5.** (a) PDF of PJM RegA hourly energy bias during June–August 2017; (b) PDF of PJM RegD hourly energy bias during June–August 2017.

Thus in our study, we compare the use of flywheels and lithium-ion batteries in four different cases: (1) the PJM-RegD, representing a storage-friendly fast regulation signal, (2) PJM-RegA, representing a slow regulation signal, (3) PJM-RegA plus PJM-RegD, representing the original PJM regulation signal, and (4) the NYISO regulation signal. All signals are actual regulation signals downloaded from the PJM and NYISO websites.

### Payments for Providing Regulation Services

Following FERC Order 755, all ISO/RTOs have implemented a pay-for-performance regulation market. Under this market mechanism, participating resources are rewarded by regulation power capacity,  $P_{bid}^{reg}$  and regulation mileage,  $M$ . The capacity offering price is in \$/MWh. The unit for mileage price is \$/ΔMW. In most regulation markets, a participating unit commits a  $P_{bid}^{reg}$ , for a bidding interval with a length  $T$ .  $P_{bid}^{reg}$  is symmetrical in most ISO control areas, except in CAISO. “Symmetrical” means that the regulation-up and regulation-down signals have the same power limit of  $P_{bid}^{reg}$ . The regulation instructional signal at time  $t$ ,  $P_t^{reg}$ , is a normalized percentage of  $P_{bid}^{reg}$ . To guarantee that regulation signals are within the committed regulation capacity limit of the unit, we always have:

$$|P_t^{Reg}| \leq 1 \quad (1)$$

Regulation mileage is the sum of absolute values of the regulation control signal movements. If the output of a regulation unit is  $P_t^{Reg}$  and the declaring regulation capacity is  $P_{bid}^{reg}$ , the regulation mileage is calculated:

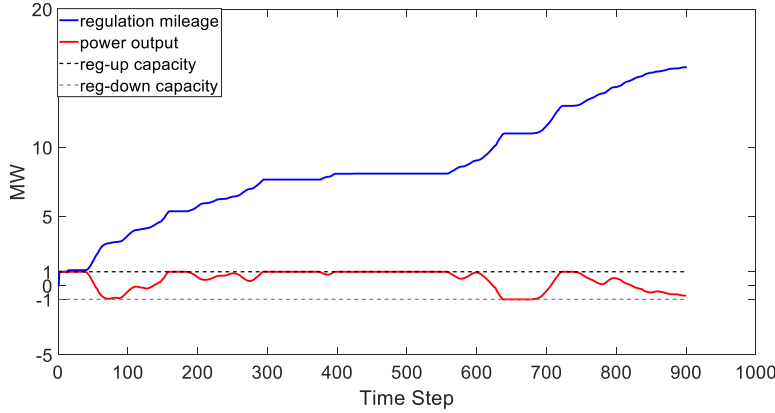
$$M = \sum_0^T \frac{|P_t^{reg} - P_{t-1}^{reg}|}{P_{bid}^{reg}} \quad (2)$$

Usually, system operators will calculate a performance factor ( $\lambda$ ) with a value between 0 and 1, to represent the response accuracy with respect to the regulation instructions. Depending on the market design, the performance factor is calculated and applied differently. Its purpose is to decrease the regulation payment to account for inaccuracy in response. A general penalization format is as follows:

$$\text{Payment} = P_{bid}^{reg} (\rho_c + \lambda M \rho_M) \quad (3)$$

where  $\rho_c$  and  $\rho_M$  represent the capacity clearing price and mileage clearing price, respectively. Since lithium-ion batteries and flywheels can have high response accuracy when providing the regulation service, we assume  $\lambda = 1$ , i.e., there is no payment penalization.

Figure 6.6.6 shows an example of the energy storage power outputs when responding to regulation signals. The regulation-up capacity is equal to the regulation-down capacity (i.e.  $\pm 1\text{MW}$ ), as shown by the dotted lines. The regulation mileage is shown by the blue line, which keeps increasing whenever there is a change in energy storage power output, as shown in Equation 2.



**Figure 6.6.6.** An example of regulation capacity and mileage.

### Energy Storage Models and Lifetime Estimation Methods

We assume that Li-ion batteries and flywheels can ramp up or down to any power output within its rated power in milliseconds so that the instruction regulation signals can be followed accurately and immediately, unless the unit is fully charged or discharged. The storage charging and discharging process and constraints can be modeled as

$$E_t - E_{t-1} = \Delta t \eta_c P_t^{RegDown} - \Delta t \eta_d P_t^{RegUp} - \Delta t P_t^{SelfDisc} \quad (4)$$

$$0 \leq P_t^{RegDown} \leq P_{bid}^{reg} \quad (5)$$

$$0 \leq -P_t^{RegUp} \leq P_{bid}^{reg} \quad (6)$$

$$E^{Lowerlim} \leq E_t \leq E^{Upperlim} \quad (7)$$

where  $P_t^{RegUp}$  and  $P_t^{RegDown}$  represent the regulation-up and regulation-down signals at time  $t$ , respectively;  $E_t$  is the energy level at time  $t$ ;  $E^{Upperlim}$  and  $E^{Lowerlim}$  is the storage upper and lower energy limits, respectively;  $\Delta t$  is the duration of regulation signal;  $\eta_c$  and  $\eta_d$  represent storage charging and discharging efficiency, respectively; and  $P_t^{SelfDisc}$  is the self-discharging rate.

The lifetime of a battery storage system can be estimated based on how many charging-discharging cycles it has completed at different depths of discharge (DOD), which is used to describe how deeply the battery is discharged. For example, if the battery delivers 30% of its energy, and 70% energy is reserved, the DOD of this battery is 30%. The relationship between depth of discharge and number of cycles is shown in Figure 6.6.7. Because a battery storage system providing regulation services will not run full cycles at a given DOD level, the Rain-flow method (Ke et al., 2015) is used to estimate battery lifetime depreciation. Note that the flywheel lifetime is not influenced by DOD, so its lifetime as a function of DOD is constant (see the blue line in Figure 6.6.7).

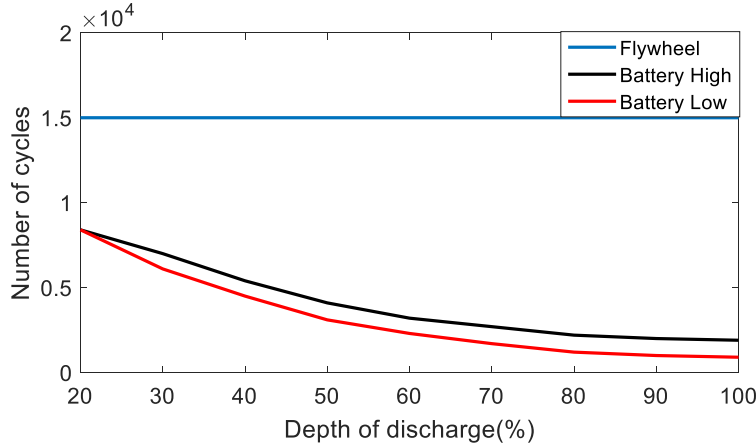


Figure 6.6.7. Storage cycles over its life versus depth of discharge (DOD).

### 5.2.4 Energy Storage Benefit-Cost Model

We assume there is no start-up or shut-down costs associated with energy storage operation when providing regulation services. The revenue  $R$ , and the cost  $C$ , can be calculated as

$$R = R_{mileage} + R_{capacity} \quad (8)$$

$$C = C_{install} + C_{O\&M} \quad (9)$$

Where  $R_{mileage}$  and  $R_{capacity}$  represent the payments for regulation mileage and capacity respectively;  $C_{install}$  and  $C_{O\&M}$  represent the cost for installation and operation and maintenance, respectively. The parameters for the lithium-ion battery and flywheel used in this study are shown in Table 6.6.1.

Table 6.6.1. Storage characteristics

ESS Technology	Lithium-ion	Flywheel
$\eta_c$	0.85	0.95
$\eta_d$	1	0.95
$p_t^{SelfDisc}$	2-4% per month	2% per hour

Because the lifetime of battery varies when responding to different regulation signals or in different modes, annualized benefits, costs, and net benefits in \$/kWyr are calculated.

#### Performance Criterion

To evaluate the regulation signal following accuracy, we define the response rate as

$$RR = \frac{n_{fulfilled}}{n_{total}} \times 100\% \quad (10)$$

where  $n_{fulfilled}$  is the number of regulation signals fully followed by the storage unit and  $n_{total}$  is the total number of regulation signals. If the storage unit has enough energy for regulation-up or enough energy space for regulation-down, the regulation signal is fully followed. Otherwise, the energy storage unit doesn't respond to the signal.

The remaining battery life after providing the regulation signal,  $L_{remain}$ , can be estimated by the rain-flow method (Ke et al., 2015). Thus, the aging ratio,  $A$ , is

$$A = \frac{L_{default} - L_{remain}}{L_{default}} \times 100\% \quad (12)$$

where  $L_{default}$  is the default lifetime of a battery.

### Simulation Setup

The following assumptions are made when performing the simulation:

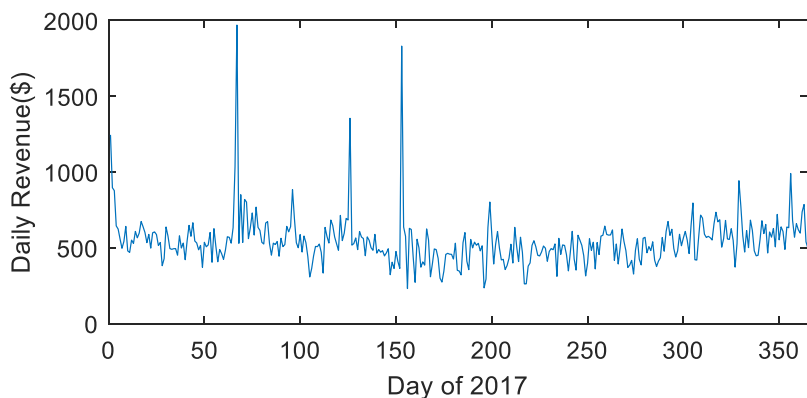
- For one-directional service, the battery/flywheel is fully charged when  $t = 0$ .
- For bi-directional service, the SOC of the battery/flywheel is 50% when  $t = 0$ .
- The battery/flywheel is always online (charging, discharging, or idling), so the start-up or shut-down costs are not considered.
- The default battery life is assumed to be 10 years, and the default flywheel lifetime is assumed to be 21 years.
- The rated power of the battery and flywheel is 1 MW and the energy capacity is 0.5MWh, unless specified otherwise.
- Regulation signals are downloaded from the PJM and NYISO websites. The PJM regulation signal includes two parts: PJM RegD and PJM RegA. The NYISO regulation signal has not yet been divided between fast and slow units, so only one signal is used. Regulation signals and corresponding price data in 2017 are used to conduct the analysis.
- When calculating annualized costs and benefits, the annual discount rate is 10%.

### 6.6.4 Simulation Results

As introduced in previous sections, regulation signals and the corresponding price data in our study were downloaded from PJM (i.e. RegD and RegA) and NY-ISO website. The data resolution is 2-second for PJM and 6-second for NY-ISO. The data was collected from January 1<sup>st</sup> to December 31<sup>st</sup>, 2017. Using the aforementioned parameters and simulation settings, we calculate the mileage and response rate of the Li-ion battery and flywheel when providing regulation services. The rain-flow algorithm is used to estimate the lifetime of the Li-ion battery storage system assuming that the designed lifetime of battery is 10 years.

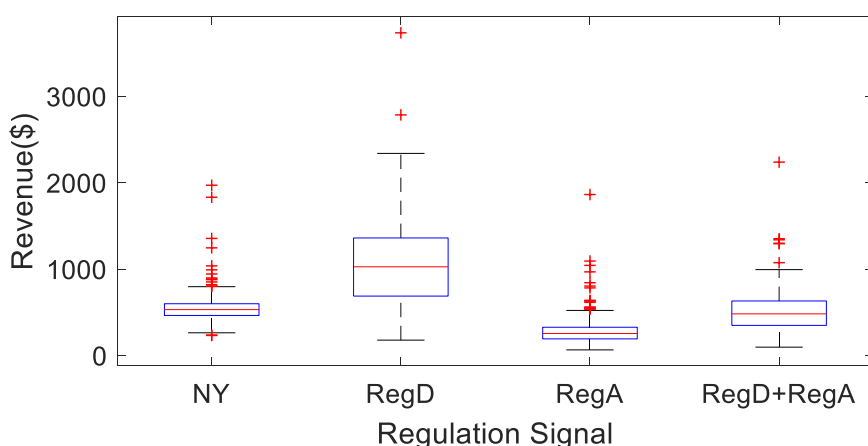
#### Impact of using Different Regulation Signals

For this part of the analysis, we assume the service is provided by a lithium-ion battery in bi-directional mode. The performance criterion and daily revenue is calculated assuming that the DOD is at 50% at the beginning of each day and parameters of the battery are as listed in Table 6.6.1. Figure 6.6.8 shows the daily revenue over the whole year. As the revenue is calculated from the regulation service price, the revenue will spike when regulation prices spike. The maximum revenue is \$1970, the minimum revenue is \$231, and the mean value is 542 \$/day.

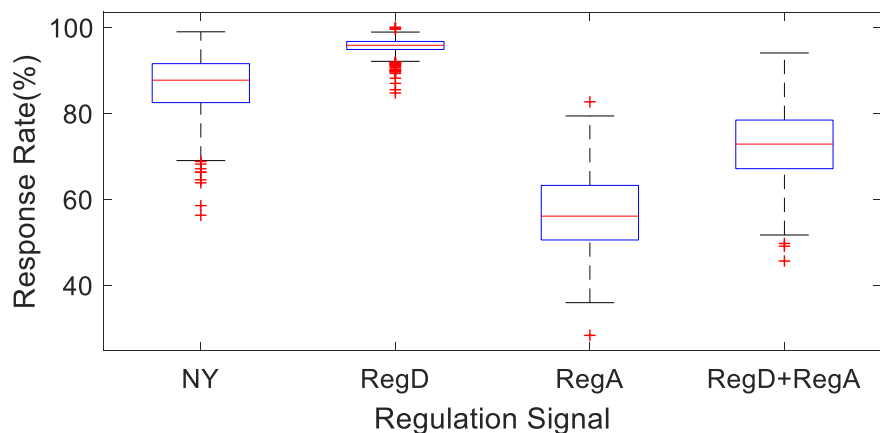


**Figure 6.6.8.** Daily revenues for providing 2017 NYISO regulation signals.

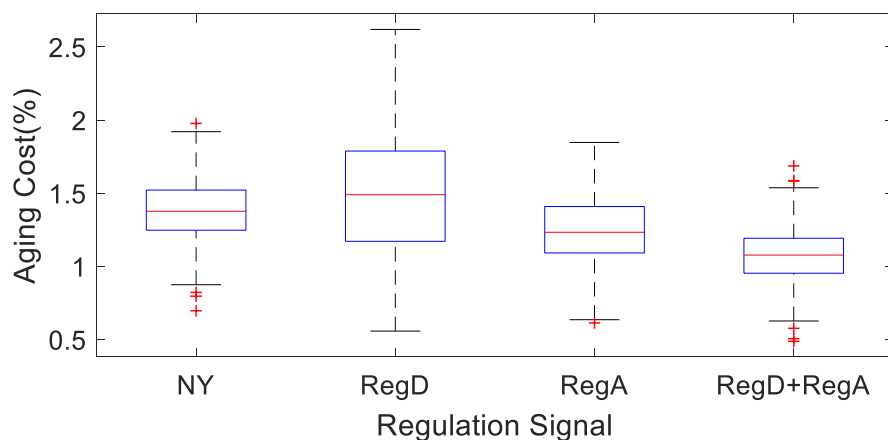
Figures 6.6.9, 6.6.10, and 6.6.11 show the statistical spread in daily revenue, response rate, and aging cost, respectively, for the lithium-ion battery. From the results, we have several observations. First, as shown in Figure 6.6.9, revenue is the highest when providing RegD signals, almost twice as much as the revenues received for other types of regulation signals. This result is due in part to PJM’s higher market clearing prices for regulation mileage compared with NYISO. For example, in June 2017, the PJM mileage price was \$2.9334/MW and \$0.1868/MW in NYISO. Second, as shown in Figure 6.6.9, for NYISO and PJM, the revenue is similar if PJM does not allow regulation signals to be separated into RegD and RegA signals. Third, as shown in Figure 6.6.10, the response rates are the highest for the RegD signal, as it is designed to be energy-neutral and the lowest for the RegA signal, which is energy-biased because the energy-neutral RegD signal has been separated out. As can be seen in Fig. 6.6.10, NY-ISO and PJM signals are different, causing 10% differences in response rate. Fourth, as shown in Figure 6.6.11, when following RegD signals, the battery mileage and lifetime depreciation increase. This result shows that there is a tradeoff between providing the high value RegD signal and increased service cost.



**Figure 6.6.9.** Comparison of daily revenue across the year, associated with following different signals.



**Figure 6.6.10.** Comparison of daily response rate.



**Figure 6.6.11.** Comparison of lifetime depreciation. Note that aging cost is the percentage of life reduction after one day of service.

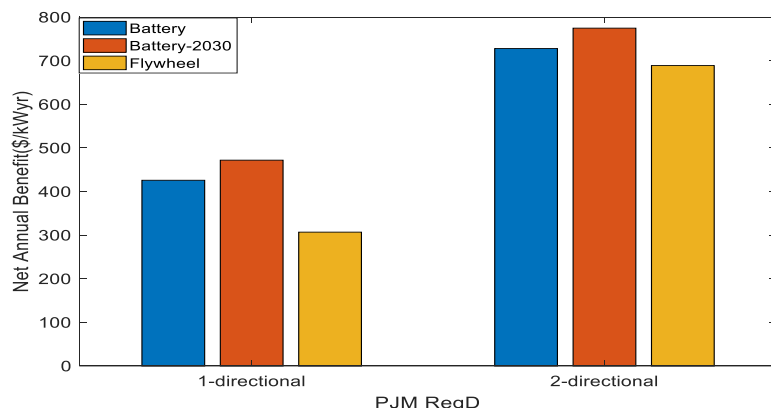
### Comparison of Different Technologies

Because RegD is designed to be a storage-friendly regulation signal, we use RegD to compare the performance of two different types of storage technologies: lithium-ion batteries and flywheels. Both 1-directional and 2-directional modes are considered. The power capacity of both devices are set at 1 MW and the energy capacity is 0.5 MWh. The initial energy for both devices is 0.25 MWh. Cost parameters of the lithium-ion battery and flywheel are listed in Table 6.6.2. We calculated the annual revenue received when providing ancillary services in 2017 and assume the same revenue can be received over the entire storage unit lifetime.

**Table 6.6.2.** Storage cost parameters

	Li-ion(0.5hr)	Li-ion(2hr)	Li-ion(4hr)	Flywheel
Current Cost (\$/kWh)	1162	498	369	4541
2030 Cost (\$/kWh)	532	228	200	4541
O&M(\$/kW-yr)	2	8	15	7

As shown in Figure 6.6.12, the annual net benefit for both the battery and flywheel is positive when supplying RegD, indicating that for both 1-directional and 2-directional services, the operation is profitable. The net annual benefit of the 2-directional service is higher than that of the 1-directional service, due to the higher response rate and more mileage payments. The flywheel and lithium-ion battery have similar performance. For one-directional service, the annual net benefit from the 0.5-hour Li-ion battery is \$426/kWyr (2019 battery cost), compared with the flywheel net benefit of 307 \$/kWyr. For bi-directional PJM RegD service, the annual net benefit of the 0.5-hour Li-ion battery is approximately \$30/kWyr higher than the flywheel.



**Figure 6.6.12.** Comparison of lithium-ion and flywheel net benefit for 1-directional and 2-directional services.

We also compared the flywheel and lithium-ion battery performance for the other types of regulation signals when providing 1-directional and 2-directional services. The results are summarized in Table 6.6.3.

**Table 6.6.3.** Performance comparison when using different types of regulation signals and charging methods

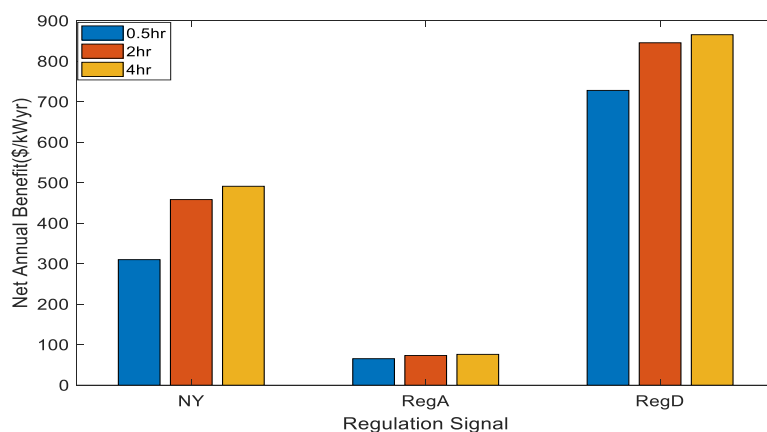
	PJM RegD		PJM RegA		NY-ISO	
	1-direction	2-direction	1-direction	2-direction	1-direction	2-direction
<b>Battery</b>						
Annual net benefit (\$/kW·yr)	426	728	81.0	65.4	201	310
Response Rate (%)	49.4	95.0	34.8	55.7	48.1	85.5
Estimate Lifetime (yrs)	4.72	3.89	5.93	4.23	5.28	3.99
<b>Flywheel</b>						
Annual net benefit (\$/kW·yr)	307	689	14.3	551	56	227
Response Rate (%)	49.6	94.9	35.4	59.1	47.7	86.3
Estimated Lifetime (yrs)	20	20	20	20	20	20

From the simulation results, the following two observations are made. First, if regulation signals are designed to be energy storage friendly, we can use energy storage to provide high-quality regulation services. As shown in Table 6.6.3, energy storage performance is best when supplying the PJM

RegD signal. The response rate for both battery and flywheel are the highest when responding to the PJM RegD signal. The PJM RegA is the most unfriendly to energy storage. The response rate of the battery supplying PJM RegA signal in bi-directional mode is only 55.7%, much smaller than that of supplying PJM RegD (95.0%) and NY-ISO (85.5%) signals. As mentioned before, Reg D and Reg A represent two distinct parts of the traditional regulation signal, similar to the single NY-ISO regulation signal. RegD is the part designed as energy-neutral, suitable for energy storage systems, while RegA is the remaining part, which has a large energy bias. If ranked by the friendliness to energy storage, we have Reg D > NY-ISO > Reg A, which is supported by the simulation results. Second, the battery and flywheel have similar technical performance in terms of response rate because both technologies respond fast and they have the same power and energy rating. Although the Li-ion battery exhibits significant degradation, our model results indicate that it is still more cost-effective than the flywheel.

### Comparison of Different Battery Durations

Lastly, we compared the annual net benefit when using different Li-ion battery durations: 0.5 hour, 2 hour and 4 hour. The cost parameters are shown in Table 6.6.2. All three regulation signals are used and bi-directional service is considered. The initial energy is half of its maximum energy. As shown in Fig. 6.6.13, for all three markets, the longer the battery duration, the higher the net annual benefit. This result suggests that the incremental benefit associated with longer duration batteries exceeds the incremental cost. Furthermore, as shown in Figure 6.6.13, running on shallow charging/discharging cycles causes less lifetime depreciation. For example, the service life of a 0.5 hour, 2-hour, 4-hour battery supplying the RegD signal are 3.8 years, 5.5 years and 10 years, respectively. It is important that a suitable energy size is selected to avoid the batteries being operated at low DOD for long durations.



**Figure 6.6.13.** Comparison of net annual benefits for different Li-ion battery durations.

### 6.6.5 Conclusions

In this study, benefit-cost analysis is conducted to compare the performance and profitability of lithium-ion batteries and flywheels providing grid regulation services. Because Duke Energy ACE signals are “business confidential” data, we used regulation data collected by PJM and NY-ISO to benchmark the performance and the economics of using energy storage for providing regulation services.



It is worth pointing out that in this study the revenue is calculated using the market clearing price, which is an idealized assumption when a market is saturated. Since the required amount of regulation capacity is limited, this market can easily become saturated by too many price-taking participants. For example, operational evidence shows the PJM RegD market became saturated in 2016. Two main factors led to the rapid saturation of PJM RegD market: (1) implementation of a pay-for-performance market in PJM contributed to a 236 MW increase in installed energy storage capacity in PJM from 2012 to 2016, with more than 90 percent of that capacity participating in the regulation market; (2) the rush of energy storage projects exposed some flaws in the design of PJM's frequency regulation market. For example, the energy neutrality constraint led RegD resources to maintain power balance, regardless of the grid's reliability needs. PJM revised the market design and capped the share of RegD resources at 40 percent – down from an original cap of 62 percent – and established a 26.2 percent cap for RegD resources providing regulation service during certain morning and evening “excursion hours” (Cannon Jr. et al., 2015).

The regulation market size can be estimated at 2-3% of system load, though it is closely related to the penetration level of renewable energy. Before launching fast regulation signals, it is critical to find the optimal mix of fast and slow regulation resources on the system. The fast component should be energy-neutral and can be supplied by energy storage, and the slow component can be supplied by conventional units.

## References

Leitermann O (2012). Energy storage for frequency regulation on the electric grid. Ph.D. dissertation, Dept. Elect. Eng. Commun. Sci., Massachusetts Inst. Technol., Cambridge, MA, USA, Ch. 1 and 2.

PJM ancillary services market-based regulation data. Retrieved June 3, 2018, from <https://www.pjm.com/markets-and-operations/ancillary-services.aspx>

NYISO market data. Retrieved June 18, 2018, from [https://www.nyiso.com/public/markets\\_operations/market\\_data/pricing\\_data/index.jsp](https://www.nyiso.com/public/markets_operations/market_data/pricing_data/index.jsp)

North American Electric Reliability Corporation Std. BAL-001-2(2008). Real Power Balancing Control Performance. Retrieved August 18, 2018, from <https://www.nerc.com/pa/Stand/Reliability%20Standards/BAL-001-2.pdf>

ISO-NE (2010). Final Report: New England Wind Integration Study. Retrieved August 18, 2018, from [https://www.iso-ne.com/static-assets/documents/committees/comm\\_wkgrps/prtcpnts\\_comm/pac/reports/2010/newis\\_report.pdf](https://www.iso-ne.com/static-assets/documents/committees/comm_wkgrps/prtcpnts_comm/pac/reports/2010/newis_report.pdf)

FERC (2011). Frequency regulation compensation in the organized wholesale power markets (order no. 755). Retrieved August 26, 2018, from <https://www.ferc.gov/whats-new/comm-meet/2011/102011/E-28.pdf>

NERC (2011). Balancing and frequency control. Retrieved November 29, 2018, from <https://www.nerc.com/docs/oc/rs/NERC%20Balancing%20and%20Frequency%20Control%20>

40520111.pdf Lu N, Makarov YV, Weimar MR (2010). The Wide-area Energy Storage and Management System Phase 2 Final Report. PNNL-19720. Pacific Northwest National Laboratory, Richland, Washington.

State of charge: Massachusetts Energy Storage Initiative (2017). Retrieved June 10, 2018, from <https://www.mass.gov/files/2017-07/state-of-charge-report.pdf>

FERC (2013). Third-party provision of ancillary services: accounting and financial reporting for new electric storage technologies (order no. 784). Retrieved August 20, 2018, from <https://www.ferc.gov/whats-new/comm-meet/2013/071813/E-22.pdf>

Xu B, Dvorkin Y, Kirschen DS, Silva-Monroy C, Watson JP (2016). A comparison of policies on the participation of storage in us frequency regulation markets. PES General Meeting.

PJM Manual 12: Balancing Operations, PJM (2018). Retrieved August 20, 2018, from <https://www.pjm.com/-/media/documents/manuals/m12.ashx>

Kleinman Center for Energy Policy (2017). Energy Storage in PJM. Retrieved June 21, 2018, from <https://kleinmanenergy.upenn.edu/sites/default/files/Energy%20Storage%20in%20PJM.pdf>

PJM State & Member Training Department (2016). Regulation. Retrieved June 11, 2018, from <https://www.pjm.com/-/media/training/nerc-certifications/markets-exam-materials/mkt-optimization-wkshp/regulation-market.ashx?la=en>

Ke X, Lu N, Jin C (2015). Control and size energy storage systems for managing energy imbalance of variable generation resources. IEEE Trans. on Sustainable Energy, vol. 6, No. 1.

Fooladivanda D, Rosenberg C, Garg S (2016). Energy storage and regulation: an analysis. IEEE Trans. on Smart Grid, vol. 7, No. 4.

Newbery, David (2018). Shifting demand and supply over time and space to manage intermittent generation: The economics of electrical storage. Energy Policy, vol. 113(C).

Lu N, Makarov YV, Weimar MR, Rudolph F, Murthy S, Arseneaux J, Loutan C, Chowdhury S (2010). The Wide-area Energy Storage and Management System Phase 2 Final Report-Flywheel Field Tests. PNNL-19669. Pacific Northwest National Laboratory, Richland, Washington.

Cannon Jr. G, White JM, Whites S (2018). FERC Orders on PJM's Frequency Regulation Market Give Energy Storage Providers Another Recent Win. Retrieved November 30, from <https://www.akingump.com/en/experience/industries/energy/speaking-energy/ferc-orders-on-pjm-s-frequency-regulation-market-give-energy.html>

## 6.7. Solar Clipping

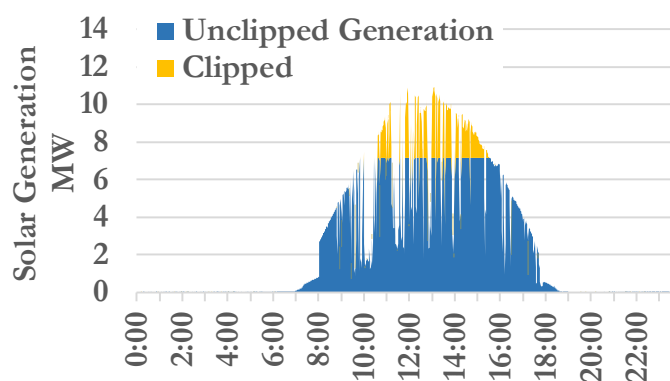
Electricity generation from a solar photovoltaic project is directly related to the solar resource intensity at a given time. This resource and the corresponding solar generation varies throughout the day as well as seasonally, resulting in a limited number of hours per year when a solar array is generating at its rated capacity.

Grid-connected solar photovoltaic projects use inverters to convert DC generation to AC generation. Given the limited share of time that a solar array is producing electricity at its rated DC output, it can be economically advantageous to “undersize” an inverter. The ratio between the array’s DC nameplate capacity and the inverter’s peak AC output rating goes by several terms: inverter loading ratio (ILR), DC/AC ratio, array-to-inverter ratio, inverter sizing ratio, and DC load ratio, among others (Bolinger, 2017).

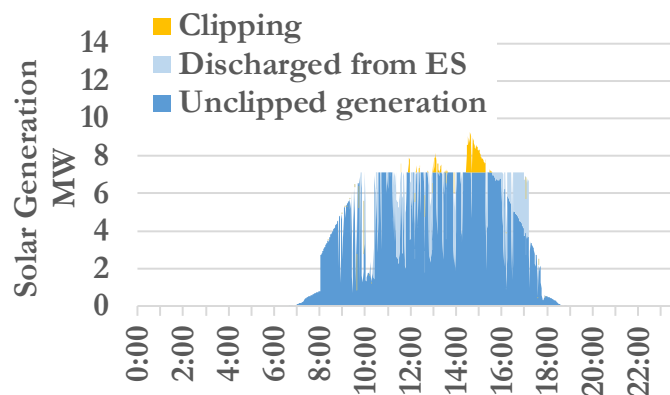
Figure 6.7.1 shows the implications of this design approach on a hypothetical high solar generation day. In this example, the inverter’s peak AC output is 7.1 MW. Any time that the array’s generation exceeds this amount, the excess generation is “clipped,” reducing the potential generation that could serve load.

Power clipping or power limiting is managed electronically, achieved by having the inverter induce inefficiency by moving away from the maximum power point. Such losses are the result of system design, which seeks to reduce both inverter costs and clipping losses. Lawrence Berkeley Labs reports that, in the U.S. in 2016, the median utility-scale solar project for both fixed tilt and single axis tracking has a DC/AC ratio of 1.31, with the 80<sup>th</sup> percentile of fixed tilt projects reaching a ratio of 1.46 (Bolinger, 2017). Note that to accurately quantify the magnitude of solar clipping, it is necessary to have high temporal resolution; hourly level data mask the actual solar clipping (Good, 2016).

Energy storage can and has been deployed to reduce solar clipping, with the potential to improve the financial viability and operational control of solar projects. By integrating energy storage on the solar array side of the inverter, the timing



**Figure 6.7.1.** A representative example of solar clipping, assuming a DC/AC ratio of 1.4.



**Figure 6.7.2.** The potential reduction in solar clipping using a 3 MW/3 MWh battery.

of the DC generation can be better managed to decrease solar clipping, which in turn increases overall AC production and inverter utilization. Building off the example presented in Figure 6.7.1, Figure 6.7.2 shows the impact of introducing a 3 MW/3 MWh DC-coupled battery to reduce solar clipping. The dark blue represents the baseline solar generation, the light blue represents the avoided solar clipping that was stored in the battery, and the gold represents the remaining amount of clipped solar. In this example, the introduction of the energy storage system reduces solar clipping by over 80%. In addition, the introduction of the battery greatly increases the share of time that the project generates at maximum AC output. In this example, during hours of generation, the project is at maximum output 29% of the time without energy storage and 47% with energy storage. The ability to better manage and flatten the project's output serves to reduce system integration costs and the need for load following generation.

### 6.7.1 Solar Clipping Methods

To better understand the potential for energy storage to reduce solar clipping in North Carolina, we analyzed one-minute resolution solar resource data for 2017 from four North Carolina sites, provided by Strata Solar under a non-disclosure agreement. Using real solar generation data from four of their sites, we determined the relationship between irradiance and potential generation without inverter constraints ( $r^2 = 0.98$ ) to allow us to quantify the clipping losses as a function of the solar project's DC/AC ratio. We then introduced a DC-coupled lithium-ion battery energy storage system that is operated to reduce the impacts from solar clipping and maximize the value of the solar project. We estimate that the installed cost of the battery storage system is 10% lower than a stand-alone system due to the elimination of a dedicated inverter and we assume that the full value of the Investment Tax Credit (ITC) is available for the installed cost of the energy storage in 2019. We also examine battery costs in 2030 (without the ITC). We assume crystalline silicon modules, south-facing fixed tilt at 20 degrees.

For each system configuration, we model the system performance and solar clipping in the absence of energy storage. We then integrate energy storage with two operational strategies: (1) minimize clipping and discharge the battery as soon as there is available inverter capacity, which is indicative of a solar project with non-varying value streams (e.g., fixed rate PPA); (2) maximize solar project net revenues assuming time-of-day varying energy values. The first approach assumes that all generation is compensated equally, while the second approach using historical system lambda values (i.e., historical marginal costs of the system) to represent the time-varying energy value.

Table 6.7.1 summarizes the scenarios that we examined. At each of four locations across North Carolina, we consider nine DC/AC ratios ranging from 1.2 to 2.0. We then consider 30 possible battery configurations, testing 1 MW to 5 MW of storage with one to six hours of storage capacity.

**Table 6.7.1.** Summary of solar clipping scenarios examined

Parameter	Values Considered	Description
Location	4 sites in North Carolina	Minute-level solar resource and generation data for one year
Array Design	10 MW <sub>DC</sub> fixed tilt	Fixed tilt at 20 degrees, south-facing
DC/AC Ratio	1.2 to 2.0, in 0.1 increments	Rated inverter capacities range from 5 MW <sub>AC</sub> to 8.3 MW <sub>AC</sub>
Energy Storage Rated Capacity	1 to 5 MW, in 1 MW increments	Five rated power capacities are considered for each DC/AC ratio
Energy Storage Duration	1 hour to 6 hours at rated power, in 1 hour increments	The rated MWh of the energy storage system is varied between one and six hours of discharge at the battery's rated power
Energy Value	Fixed price = \$35/MWh Varying price = 2017 system lambda values	

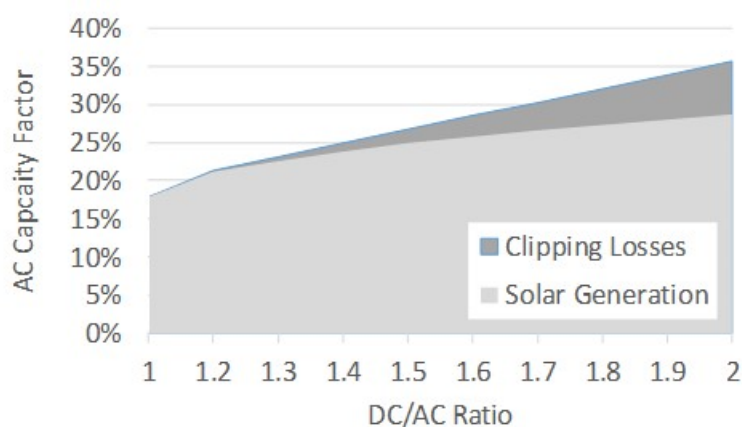
For this analysis, we examine lithium-ion batteries with an assumed roundtrip efficiency of 85%. In addition to the energy value provided by the energy storage, we also assume a capacity value. To estimate the capacity value of the storage unit, we rely on a method by Sioshansi et al. (2014) in which we assume batteries of 1, 2, 3, 4, 5, and 6 hours of duration receive capacity credit of 41%, 56%, 66%, 75%, 80%, and 85%, respectively. We value capacity at the cost of new entry for a combustion turbine plant (\$113/kWyr).

For each of the solar project designs and contract structures, we determine the battery design with the highest net system benefits. In addition, for scenarios in which the cost exceed the benefits, we calculate the breakeven cost of storage needed to reach parity.

### 6.7.2 Solar Clipping Results

Figure 6.7.3 shows the relationship between the solar DC/AC ratio and the magnitude of clipping losses, using a representative North Carolina site and a fixed tilt solar array design. With an industry average DC/AC ratio of 1.3, we observe clipping losses that total 2.3% of the potential generation. With a DC/AC ratio of 2.0, we see clipping reach nearly 20% of the potential solar generation.

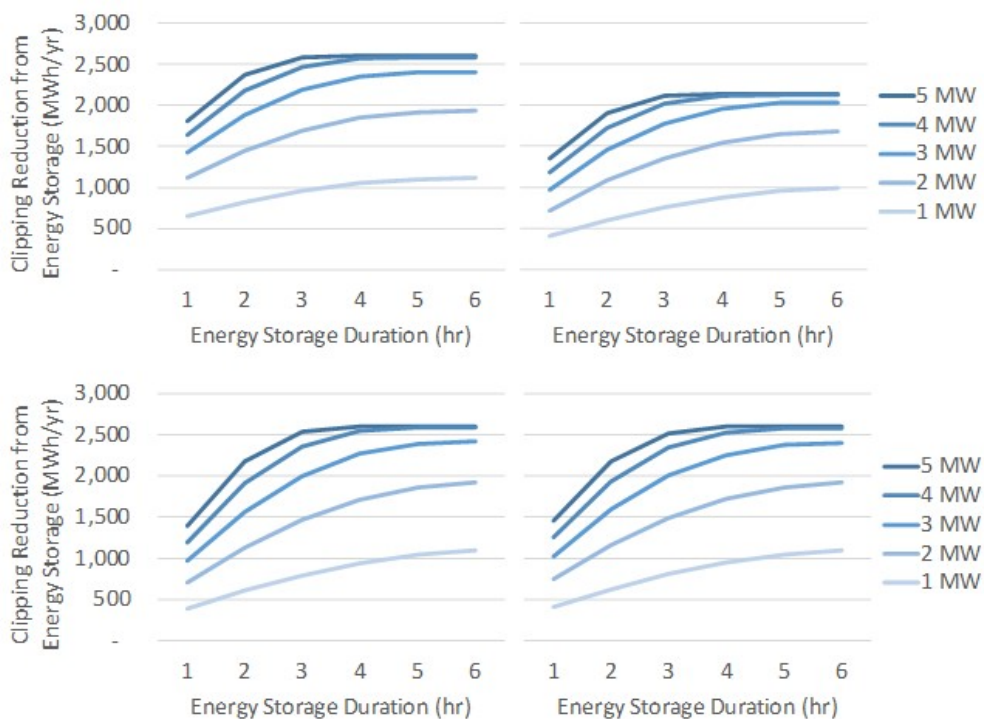
For the purposes of this analysis, we assume a 10 MW<sub>dc</sub> solar installation and vary the size of the inverter to achieve the range of DC/AC ratios. Without inverter



**Figure 6.7.3.** Solar clipping losses without energy storage a representative North Carolina location across a range of DC/AC ratios at a representative North Carolina location

constraints, the four sites would produce between 14,670 and 15,710 MWh per year, equating to DC capacity factors of 16.7% to 17.9%. With a DC/AC ratio of 2.0, representing a higher inverter loading ratio that could fully take advantage of storage, we calculate that between 2,510 and 3,060 MWh<sub>ac</sub> of generation per year would be lost due to clipping during peak production hours.

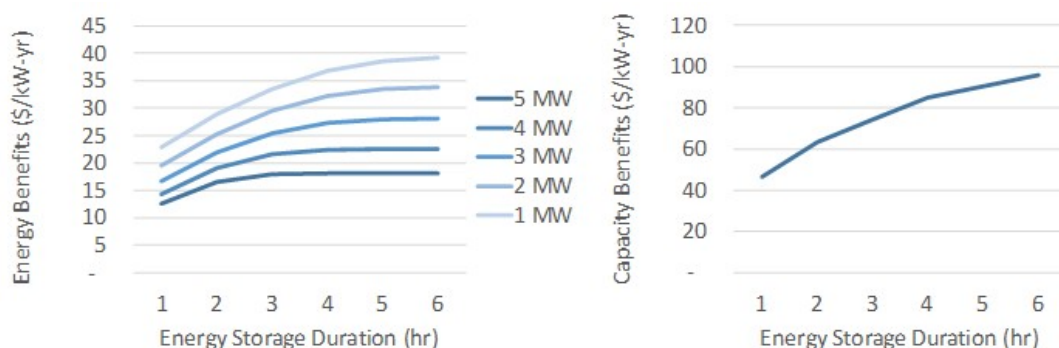
Figure 6.7.4 shows the reduction in solar clipping using a lithium-ion battery at four representative 10 MW<sub>dc</sub> solar farms with a DC/AC ratio of 2.0. Each line represents a different charge/discharge capacity (MW) for the battery, while the x-axis shows battery duration in terms of hours. Larger batteries, in terms of both MW and MWh, yield greater reductions in solar clipping. This result is consistent with expectations: longer duration batteries would recover more clipping losses during extended high insolation periods; higher charging rates would capture more of the lost generation. For the largest batteries, however, we observe diminishing benefits. The 5 MW/20 MWh battery (i.e., four hour duration) recovers nearly all of the lost generation after accounting for the 85% round trip efficiency of the battery.



**Figure 6.7.4.** The potential reduction in solar clipping using lithium-ion batteries at four hypothetical 10 MW<sub>dc</sub> solar projects in North Carolina with a DC/AC ratio of 2.0: (a) northern location, (b) southern location, (c) eastern location, (d) western location.

With these findings, which illustrate the magnitude of solar clipping reductions as a function of battery size, we can calculate and compare the costs and benefits of battery integration. For the remainder of this section, we will present the results from one solar site (i.e., the northern site), given the small variation in results across the four considered sites. Figure 6.7.5 shows the energy and capacity benefits of solar clipping reduction from batteries of varying sizes, assuming fixed rates

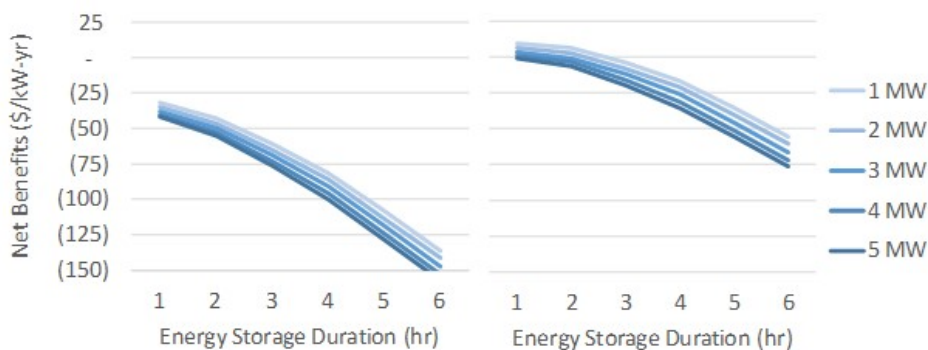
throughout the day and year. The energy benefits are calculated based on the total clipping reduced (after battery losses) and a value of solar of \$35/MWh, indicative of recent solar power purchase



**Figure 6.7.5.** Energy and capacity benefits from solar clipping reduction at a 10 MW<sub>dc</sub> site in northern North Carolina. Assumes a DC/AC ratio of 2.0, energy revenues of \$35/MWh, and capacity credits that increase with battery duration, as described in the text.

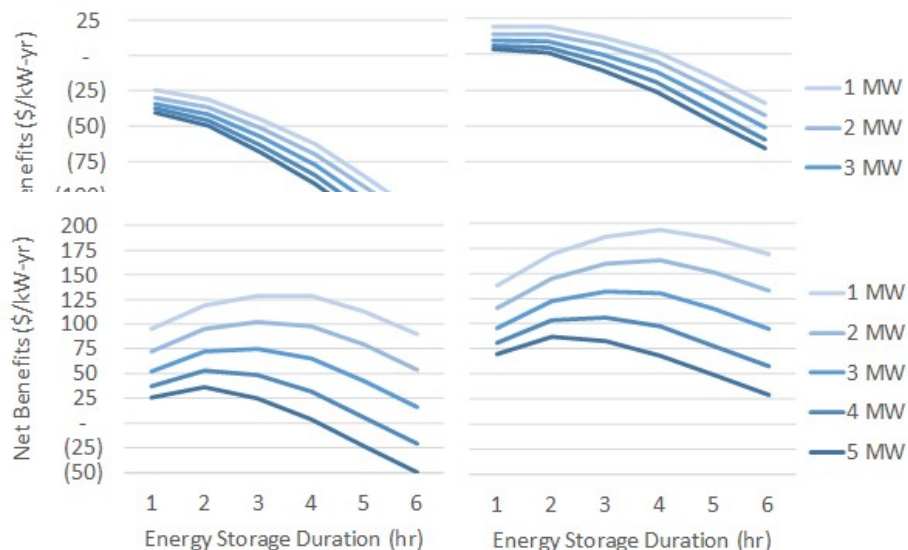
agreements without additional value from renewable energy credits (RECs). We also test the results to two values for RECS. The energy benefits would scale proportionally with higher or lower energy values for solar. Because the capacity benefits are normalized to \$/kWyr, these benefits are identical across the range of battery power capacities. Across all battery configurations, we observe that the capacity benefits exceed the energy benefits.

Figure 6.7.6 shows the net economic benefits of solar clipping reduction in 2019 and 2030. This calculation includes the full value of the investment tax credit in 2019 and uses our base case assumptions for battery costs (interpolated when necessary), reduced by 10% to estimate the impact of eliminating the inverter. These findings show that, with flat energy revenues of \$35/MWh and at current battery costs, net benefits in 2019 are negative for all battery configurations. To achieve breakeven benefits in 2019 with flat-rate solar energy revenues, we would need a 31% reduction in battery costs *or* solar energy prices to reach \$83/MWh. Using 2030 battery costs (without the ITC), however, we observe positive net benefits for short duration (i.e., 1 and 2 hour) batteries.



**Figure 6.7.6.** Net economic benefits of solar clipping reduction in 2019 (left) and 2030 (right), at a 10 MW<sub>dc</sub> site in northern North Carolina. Assumes a DC/AC ratio of 2.0, energy revenues of \$35/MWh, and capacity credits that increase with battery duration, as described in the text.

The results shown in Figure 6.7.6 are indicative of a flat rate, \$35/MWh solar value without additional compensation from RECs or solar renewable energy credits (SRECs). The values for RECs and SRECs vary widely by location. There is some eligibility for solar projects in the Dominion service territory to sell RECs and SRECs into other states within PJM. We tested the impact of valuing \$18/MWh RECs and \$200/MWh SRECs, indicative of recent pricing in the PJM region (Monitoring Analytics, 2018). Figures 6.7.7 and 6.7.8 show considerable increases in the net benefits from energy storage when the solar project is able to sell RECs or SRECs into PJM.



**Figure 6.7.8.** Net economic benefits of solar clipping reduction in 2019 with \$200/MWh value for solar renewable energy credits in 2019 (left) and 2030 (right) at a 10 MW<sub>dc</sub> site in northern North Carolina. Assumes a DC/AC ratio of 2.0, energy revenues of \$35/MWh, and capacity credits that increase with battery duration, as described in the text.



The findings presented up to this point assume that the energy value of solar is held constant throughout the day and year at \$35/MWh (plus REC or SREC values, when applied). We also examined time-varying solar energy values, which would provide additional compensation during times of high demand on the grid. To do this, we assumed that solar energy revenues would be equal to 2017 hourly system lambda values for Duke Energy Carolinas, as obtained from FERC Form 714 (Federal Energy Regulatory Commission, 2018). Instead of minimizing solar clipping, the batteries were used to maximize energy revenues over a 24 hour period, assuming perfect foresight into the day ahead energy rates and solar generation. We performed these calculations on the 10 MW<sub>dc</sub> solar farm with a DC/AC ratio of 2.0 and a 1 MW battery ranging in duration from 1 to 4 hours.

After accounting for the roundtrip losses, the net increase in value of the energy that passed through the storage system ranged from \$2.60/MWh to \$2.90/MWh. This relatively modest change was driven by two main factors. First, there was a narrow range of system lambdas in 2017, limiting the spread between charging and discharging. The energy value for 80% of the hours fell between of \$26/MWh to \$36/MWh. Second, the hours of solar generation and battery discharge under fixed rates skewed toward higher energy values, leaving less opportunity for arbitrage. Based on this modeling, the increase in energy benefits when using energy storage to reduce solar clipping while considering the marginal cost of generation on the grid ranges from \$1/kWyr (for a one hour duration battery) to \$3/kWyr (for a four hour duration battery). These results are specific to recent historical costs for North Carolina. Other regions experience far wider ranges of marginal costs due an abundance of wind (e.g., Texas) or solar (e.g., California) or larger differences between the cost of natural gas and coal generation.

## References

Bolinger M, Seel J, LaCommare KH. (2017). Utility-Scale Solar 2016: an empirical analysis of project cost, performance, and pricing trends in the United States. Lawrence Berkeley National Laboratory.

Federal Energy Regulatory Commission (FERC), (2018). Form 714, <https://www.ferc.gov/docs-filing/forms/form-714/data.asp>, accessed 11/20/2018.

Good J, Johnson JX. (2016). Impact of inverter loading ratio on solar photovoltaic system performance. Applied Energy 177, 475-486.

Monitoring Analytics, (2018). PJM State of the Market.

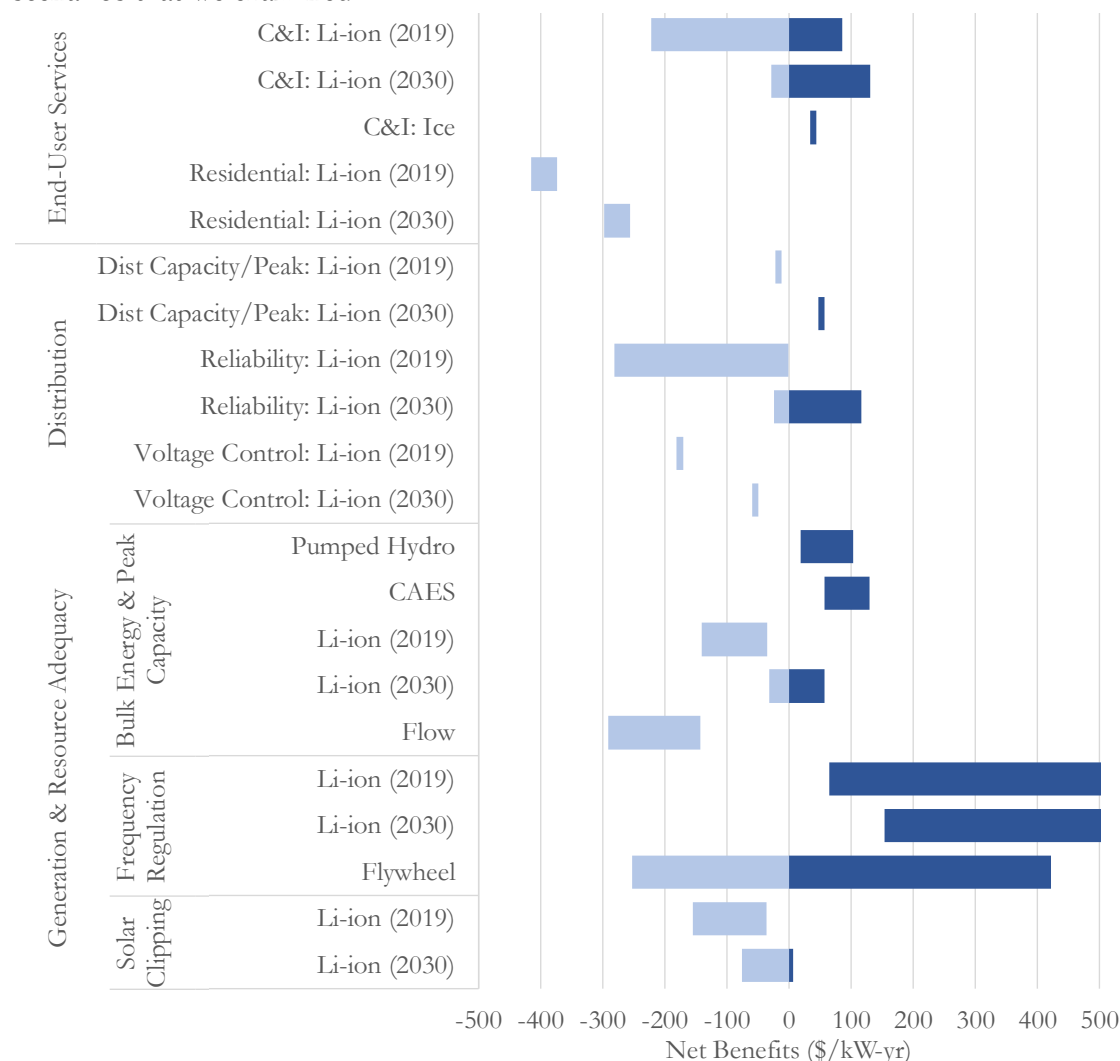
Sioshansi, Ramteen, Seyed Hossein Madaeni, and Paul Denholm. (2014). "A dynamic programming approach to estimate the capacity value of energy storage." IEEE Transactions on Power Systems 29.1: 395-403.

## 7. Synthesis Across Service Categories and Value Stacking

Section 6 provides detailed technical and economic analysis associated with using storage to fulfill specific storage-related services. The purpose of this section is to synthesize the results and draw high-level insights about the potential economic value of storage through 2030. This section provides a summary of the benefit-cost results across the different service categories, estimates the potential market size for storage fulfilling different services, and discusses the potential for value stacking within North Carolina.

### 7.1 Summary of results across service categories

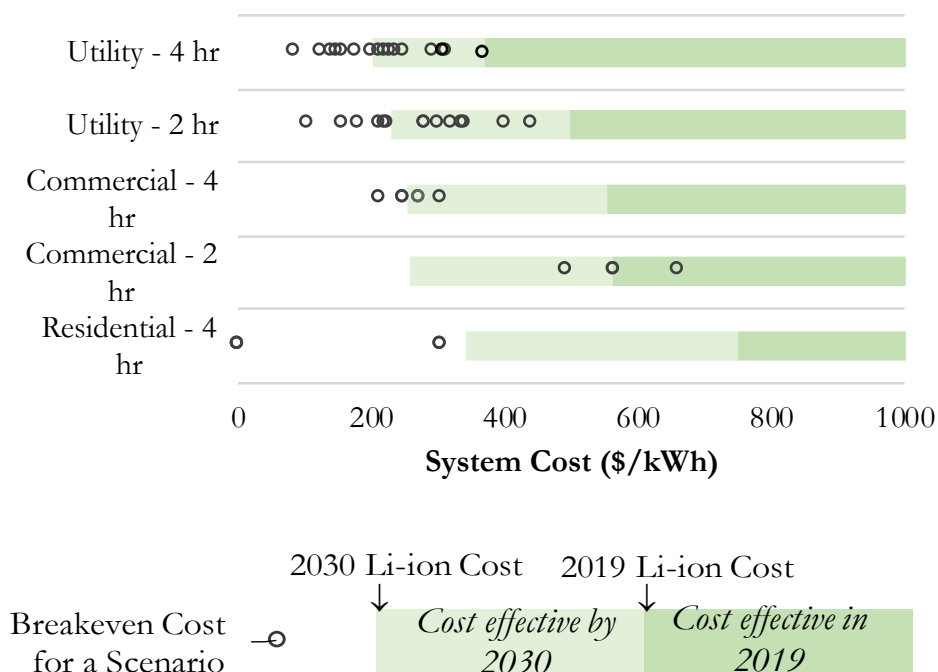
Figure 7.1 presents the range of net benefits associated with each technology across all of the scenarios that we examined.



**Figure 7.1.** Range of net benefits (\$/kWyr) for each technology and service category analyzed. Light blue bars represent negative net benefits (i.e., costs exceed benefits), while dark blue bars represent positive net benefits (i.e., benefits exceed costs). Results assuming current Li-ion battery costs in 2019 and projected 2030 costs are presented separately. Note that Li-ion battery benefits for frequency regulation exceed \$500/kWyr, but are truncated for readability.

In Figure 7.2, we show the breakeven system cost (\$/kWh) for five lithium-ion battery configurations (residential, commercial, and utility-scale with 2- and 4-hour durations). The open circles represent the breakeven battery costs across the full range of scenarios examined, including distribution, bulk energy, solar clipping, and end-user services. In this figure, a higher breakeven cost is preferable for the technology, meaning that the application examined can yield net positive economic benefits at higher technology costs. The green bars represent the cost-effective ranges based on 2019 and 2030 Li-ion costs. The darker green bar represents the cost-effective region in 2019, with the leftmost edge representing our assumed 2019 Li-ion costs. The lighter green bar extends the cost-effective region based on expected 2030 Li-ion battery costs.

As shown in the figure, the applications that are cost-effective for Li-ion batteries in 2019 are limited to 2-hour duration batteries used by commercial end users. The expected drops in Li-ion costs by 2030, however, create many more opportunities, including utility-scale applications. We observe from these results that utility-scale Li-ion deployment begins achieving net positive benefits when the technology cost drops below \$440/kWh for 2-hour batteries and below \$366/kWh for 4-hour batteries. Based on recent price declines for Li-ion batteries, we may achieve these cost targets well in advance of 2030. Residential applications begin reaching cost parity at \$290/kWh for 4-hour batteries.



**Figure 7.2.** Breakeven costs for lithium-ion batteries for utility-scale, commercial, and residential applications, compared with 2019 and 2030 forecasted technology costs.

Below we briefly summarize key insights by service category. Our aim here is not to be comprehensive, but rather to point out the most interesting insights, supported by our technical analyses in Section 6.

### End User Services

- Using Li-ion batteries to reduce commercial and industrial (C&I) coincident peak (CP) and time-of-use (TOU) charges is currently cost effective for some customers, with 2-hour duration batteries yielding the highest benefits. Price drops in Li-ion batteries will make this application attractive for more customers.
- Ice storage is currently cost-effective for commercial and industrial customers under CP and TOU rates. This result is consistent with the NC market, where over 80 ice storage projects have been implemented.
- Residential battery storage coupled with a rooftop solar photovoltaics is not cost-effective under current electricity rate design.

### Distribution

- Price declines by 2030 are expected to make the use of Li-ion batteries to provide peak capacity deferral and peak shaving at the substation as well as reliability enhancement attractive applications in the future.

### Bulk Energy Time Shifting and Peak Capacity Deferral

- For bulk energy time shifting and peak shaving, pumped storage hydro and compressed air energy storage (CAES) show cost-effectiveness today, but are highly constrained by site-specific conditions. The cost-effectiveness of pumped hydro is consistent with Duke Energy's decision to uprate the Bad Creek pumped storage facility in South Carolina, and Dominion's decision to pursue a new pumped hydro project in Virginia. New additions of pumped hydro are highly site-specific, so the cost numbers used here may not be applicable to new installations. CAES warrants further consideration, although research is required to determine whether the suitable geology exists to store the air.
- The use of Li-ion batteries does not appear to cost-effective when assuming 2019 technology prices. However, with projected 2030 costs for lithium ion batteries, up to 5 GW of battery capacity may be cost-effective for time shifting and peak shaving.
- The capacity value assigned to energy storage is a key determinant to its overall value. The capacity value of a technology represents the fraction of installed capacity that can be relied upon during peak demand periods.
- With the continued expansion of solar generation in North Carolina, energy storage used for bulk energy time shifting and peak shaving consistently reduces system-wide carbon dioxide emissions.
- Energy storage proves to be more cost-effective with higher solar penetrations because low marginal cost solar can be captured and time shifted to reduce the dispatch of less efficient power generators.

### Frequency Regulation

- Among the services we studied, frequency regulation provides the highest net benefits and represents a key near-term opportunity for storage. Though we did not have the data to analyze frequency regulation in North Carolina, data from competitive markets (PJM and NYISO) provide a strong indication that batteries can cost effectively provide frequency regulation.

- Frequency regulation can be met cost-effectively by separating the regulation signal into fast changing components, which could be energy-neutral and supplied by energy storage, and the slow moving components, which can be supplied by conventional units.
- Net benefits and battery lifetime can be increased by operating the battery cells at higher depths-of-discharge. This can be achieved by either oversizing the battery storage system or pairing the battery storage system with distributed energy resources.
- If 1-directional service is allowed by third party suppliers, regulation services can be simultaneously stacked with other services. For example, an electric vehicle charging facility can provide regulation-up service by controlling vehicle charging characteristics, without require flow back to the grid.

### **Solar Clipping**

- At current costs, DC-coupled batteries to reduce solar clipping are only cost-effective with significant value from renewable energy credits.
- The relatively flat marginal costs for electricity in North Carolina do not provide significant arbitrage opportunities for batteries to time shift the clipped solar energy.

### **Transmission Deferral and Congestion**

- We lacked the data to perform a detailed, quantitative analysis of opportunities for storage to alleviate transmission congestion or defer new transmission investments. Thus results are not included in Figure 7.1.
- To assess potential transmission investment deferral, we reviewed the NC Transmission Planning Collaborative's (NCTPC) list of projects, including the justifications for project need. Based on this review, there appear to 11 of 15 projects for which storage is *potentially* applicable. Additional data on each project would be required to quantitatively assess the value of storage.
- Our analysis of transmission congestion suggests that there is not pervasive congestion issues on our system, which would limit the potential for energy storage in this application.

## **7.2 Scale of Potential Deployment**

To provide suitable context for the results from the benefit-cost analysis, we estimate the potential scale of deployment through 2030 across the different service categories analyzed. Given the high level of uncertainty regarding future deployment levels, we devise three deployment categories: small (0-100 MW), medium (100-1000 MW), and large (greater than 1000 MW). In terms of technical limits, only frequency regulation has an upper bound in the medium category. All other service categories can – in principle – reach the large deployment category by 2030. We use our benefit-costs results across all service categories and technologies analyzed, as shown in Figure 7.1, to make an informed estimate of potential deployment levels. Given the rapid projected decline in Li-ion battery costs, we consider deployment levels through 2030 under current battery cost assumptions for 2019, and projected 2030 Li-ion battery costs. The result is shown in Table 7.1.

**Table 7.1.** Potential scale of storage deployment by service category

	2019 Cost			2030 Cost		
	Small	Medium	Large	Small	Medium	Large
End-User						
T&D						
Bulk Energy						
Frequency						
Clipping						

For commercial and industrial end user applications, we estimate that it is possible to achieve deployment in the medium to large category given the current cost-effectiveness of ice storage and 2-hour duration lithium batteries. For example, if 1% of the approximately 650,000 commercial customers (EIA, 2018) installed 200 kW systems, it would represent 1,300 MW (i.e., the “large” category). The scale of deployment for the transmission and distribution system is highly uncertain given the lack of available data characterizing overall system performance. Informed by national-level studies of energy storage market potential for transmission and distribution applications, we estimate that the deployment scale will grow from the small-medium to medium-large categories as Li-ion batteries decrease in price. With regard to bulk energy time shifting and peak capacity deferral, we observe cost-effective large scale deployments (5 GW) of pumped hydro and CAES. As noted above, however, costs and project viability are highly site specific.

As Li-ion battery costs decrease to our projected 2030 costs, our model results indicate the potential for large, cost-effective deployments of Li-ion battery. The ability of energy storage to provide frequency regulation is restricted to the medium category, simply due to the limited need for the service. Finally, the negative net benefits associated with using Li-ion batteries in the short-term for solar clipping in North Carolina limits the scale of deployment. Given the potential for more than 16 GW of solar PV capacity by 2030 and declining battery costs, however, solar clipping could reach the medium to large deployment category.

Integrated across all service categories, we envision the potential for cost-effective storage capacity to exceed 1 GW by 2030. When considering Li-ion battery deployment, given its rapidly changing costs, it is critical to evaluate all near-term investment decisions to ensure that investments in conventional generation, transmission, and distribution capacity do not lock out the ability to invest in energy storage investments that would reasonably be expected to be more economical in the next several years.

### 7.3 Value Stacking

Energy storage has the technical ability to provide a wide range of services to the power grid and its customers. As shown in our results, however, many applications for energy storage are not yet cost-effective when considered in isolation. Some of these applications only require the energy storage device to be used for a small share of time, leaving it available to serve other end uses. Termed “stacked services” or “multitasking,” energy storage can be operated to serve multiple grid roles, increasing the revenue potential and likelihood of economic viability.

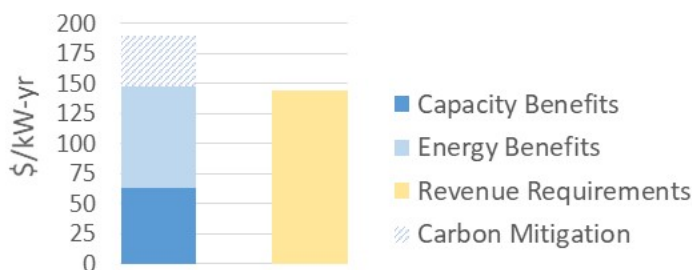
Previous studies have examined when stacking energy storage services would be feasible (Braun, 2008; Fitzgerald, 2015) and quantified the overall net benefits. In a study of battery energy storage in California, the Brattle Group found high cumulative benefits when stacking energy arbitrage, ancillary services, generation resource adequacy, transmission and distribution deferral, and CO<sub>2</sub> mitigation (The Brattle Group, 2015). Academic research has advanced optimization methods to stack services and maximize the benefits of energy storage (Cheng, 2016; Donadee, 2013; Mégel, 2015a; Mégel, 2015b). Stacking services is not as simple, however, as summing the benefits across a range of applications. There are both technical and policy related challenges to stacking services that must be considered (Forrester, 2017; Sioshansi, 2017).

Throughout our analysis as presented in Section 6, when energy storage applications are closely coupled, our modeling approach intrinsically “stacks” these services. In this section of the report, we explore the implication of this de facto stacking of services, in addition to the potential to couple dissimilar applications.

### **Bulk energy time shifting plus generation capacity deferral, with potential value from CO<sub>2</sub> mitigation**

When seeking to reduce operational costs using bulk energy time shifting (i.e., energy arbitrage), the benefits of peak generation capacity deferral are often simultaneously achieved because peak load typically corresponds with the highest energy prices. In Section 6.5 of the report, energy storage serving both of these roles is presented together (shown in Figures 6.5.9 through 6.5.15). For this combination of benefits, we assume that the energy storage devices are fully available to meet both applications, subject to the standard limits on capacity credit as a function of duration. Across the technology configurations in the Base Case, the value of capacity contributed 54% of total benefits on average, with some contributions reaching up to 90% of the total value.

In addition to the combined benefits of reducing energy costs and generation capacity costs, we also found that system-wide CO<sub>2</sub> emissions are decreased in all of these scenarios. While there is not a



**Figure 7.3.** Stacked benefits example – bulk energy time shifting, generation capacity deferral, and carbon mitigation in 2030 with a 1 GW/4GWh lithium-ion battery.

price on carbon emissions in North Carolina, some regions in the U.S. and internationally do actively price CO<sub>2</sub>. In Figure 7.3, we illustrate the relative contribution of revenues from these energy and capacity services, plus the carbon mitigation benefits valued at \$50 per metric ton of CO<sub>2</sub> (i.e., based on 2030 social costs of carbon from the U.S. EPA). In this example, we see that each of the value streams – energy, capacity, and emissions reductions – contribute sizeable shares of the total value of energy storage.

### **Distribution deferral and generation capacity deferral**

When energy storage is used to displace investments in distribution capacity, that device can be operated to reduce grid-wide peak demand, thereby alleviating the need for future generation

capacity. In Section 6.2, we consider these dual benefits as achieved through fixed charges. To effectively serve both of these applications, the energy storage device must discharge in a manner that alleviates the local distribution constraint while also meeting the system-wide peak demand. This can occur automatically if the two peaks are coincident or can be achieved through purposeful storage operations.

### **Solar clipping, bulk energy time shifting, and generation capacity deferral**

Batteries used to reduce solar clipping can also be used for energy arbitrage and peak generation capacity deferral. In Section 6.7, we investigated these multiple roles and found that generation capacity deferral can provide a large and important value stream for energy storage projects that are DC-tied to solar farms. These benefits are inherently limited to the size of the inverter, but that constraint is not necessarily binding. Our results showed that intra-day time shifting based on system marginal costs would modestly increase the benefits of storage in this application in North Carolina.

### **Combining local services with grid-scale ancillary services**

Significant attention has been paid to aggregating energy storage that is serving local applications (e.g., residential time of use rate management) to operate, when available, to provide additional grid services. In one study (Kern, 2019), researchers modeled batteries used in a system for three local services – solar clipping, residential time of use rate management, and C&I demand charge management – aggregated and operated to provide frequency regulation. They found that for every 1 MW of storage (with 2 hour duration), between 0.55 and 0.68 MW of storage could be bid into the frequency regulation market. This stacking of services would yield greater net benefits and reduce overall system costs. Given that North Carolina does not operate a frequency regulation market (excluding the portion of the state that is in PJM), this combination of services would either need to be provided by utility-owned assets or require regulatory change.

### **References**

The Brattle Group (2017). Stacked Benefits: Comprehensively Valuing Battery Storage in California.

Braun, M., Stetz, T. (2008). Multifunctional photovoltaic inverters- economic potential of grid-connected multifunctional PV-Battery-Systems in industrial environments. Proceedings of the 23rd European Photovoltaic Solar Energy Conference.

Cheng, B., Powell, W. (2016). Co-optimizing battery storage for the frequency regulation and energy arbitrage using multi-scale dynamic programming. IEEE Transactions on Smart Grid 99.

Donadee, J., (2013). Optimal operation of energy storage for arbitrage and ancillary service capacity: the infinite horizon approach. Proceedings of the IEEE North American Power Symposium (NAPS).

EIA. (2018). “Electric Power Sales, Revenue, and Energy Efficiency Form EIA-861 Detailed Data Files.” 2018. <https://www.eia.gov/electricity/data/eia861/>.



Fitzgerald, G., Mandel, J., Morris, J., Touati, H. (2015). The Economics of Battery Energy Storage: How Multi-use, Customer-sited Batteries Deliver the Most Services and Value to Customers and the Grid. Rocky Mountain Institute. [http://www.rmi.org/electricity\\_battery\\_value](http://www.rmi.org/electricity_battery_value).

Forrester, Sydney P., et al. (2017). Policy and market barriers to energy storage providing multiple services. The Electricity Journal 30.9: 50-56.

Kern, A., J.X. Johnson, and J.L. Mathieu. (2019). Environmental Impacts of Using Energy Storage Aggregations to Provide Multiple Services. In: Proceedings of the Hawaii International Conference on Systems Science (HICSS). Wailea, Maui, HI, Jan. 2019 (to appear).

Mégel, O., Mathieu, J., Andersson, G., (2015a). Scheduling distributed energy storage units to provide multiple services under forecast error. Electr. Powe Energy Syst. 72, 48–57.

Mégel, O., Mathieu, J., Andersson, G., (2015b.) Stochastic Dual Dynamic Programming to Schedule Energy Storage Units Providing Multiple Services. In: Proceedings of the IEEE PowerTech. Eindhoven, Netherlands.

Sioshansi, R. (2017). "Using Storage-Capacity Rights to Overcome the Cost-Recovery Hurdle for Energy Storage." IEEE Transactions on Power Systems 32.3: 2028-2040.

## 8. Possible Employment Impacts of Energy Storage Deployment in North Carolina

Given high levels of uncertainty, we make no direct claim about the possibility for net job creation in North Carolina from the storage sector. Instead, we provide an overview of the types of jobs needed in energy storage, some general employment trends in the storage sector, and possible ramifications for North Carolina.

### 8.1 National Energy Storage Employment

According to the DOE's 2017 U.S. Energy and Employment Report (USEER), as of the end of 2016Q1, the electricity storage industry employed 90,831.<sup>4</sup> EIA's monthly electric generator inventory, derived from form EIA-860M and which also lists utility-scale storage units, lists total storage capacity in March of 2016 at 22,874.<sup>5</sup> This suggests approximately 4 employees per MW of installed storage capacity. This value is in line with a 2017 announcement by the New York State Energy Research and Development Authority (NYSERDA). NYSERDA quoted jobs in the state's energy storage sector of approximately 3,900 in 2015 and New York had a December 2015 storage capacity of 1,426 MW, leading to about 2.75 employees per MW of installed storage.<sup>6</sup> To put these values in context, employees per MW of installed capacity for natural gas, coal, and nuclear generation are about 0.1/MW, 0.3/MW, and 0.7/MW, respectively.<sup>7</sup> The employment values for storage also do not differentiate between installation, which is likely to be more labor intensive, and maintenance, which is likely to be less labor intensive. Regardless, it appears storage, at least in the near term, is more job intensive than conventional generating sources, and the expansion of the storage sector in North Carolina would likely require employment in the sector on the order of low single digit multiples of the MWs installed.

### 8.2 NC Energy Storage Employment

Energy storage is already a significant element of the existing North Carolina energy field. In 2016, the NC Sustainable Energy Association identified 100 firms with offices and local staff in North Carolina directly linked to energy storage with a combined employment of 1,138, which represented about three percent of the total 34,294 clean energy firm employees they had identified in the state. The types of jobs spanned areas including project design and development, professional services, and research and education.

---

<sup>4</sup> The report is available at:

[https://www.energy.gov/sites/prod/files/2017/01/f34/2017%20US%20Energy%20and%20Jobs%20Report\\_0.pdf](https://www.energy.gov/sites/prod/files/2017/01/f34/2017%20US%20Energy%20and%20Jobs%20Report_0.pdf).

The 90,831 number is derived from the sum of employment across the "Pumped Hydro", "Battery Storage", and "Other Storage" fields in Figure 26 of the report.

<sup>5</sup> This data was accessed from the following site: <https://www.eia.gov/electricity/data/eia860M>. The figure was derived from summing all "Net Summer Capacity (MW)" values for technologies listed as "Hydroelectric Pumped Storage", "Batteries", and "Flywheels".

<sup>6</sup> The jobs figure cited is included in the following post: <https://www.nyserd.ny.gov/About/Newsroom/2017-Announcements/2017-01-19-NYSERDA-Announces-30-Percent-Job-Growth-in-New-Yorks-Energy-Storage-Industry>.

<sup>7</sup> These numbers are based on the March 2016 generation capacities and employment figures in Table 1 of DOE's U.S. Energy and Employment Report 2017. Note, employment in extracting the fuels associated with these generator types is not included in these employee per MW of capacity values.

### 8.3 Potential for New Job Creation

It is important to distinguish between sectoral employment, which is discussed above, and job creation, which includes the addition of completely new jobs relative to the state's total, pre-existing status quo. Given high levels of uncertainty, we make no direct claim about the possibility for net job creation in North Carolina from the storage sector, though to the extent energy storage can be cost-effectively deployed to reduce the cost of generating, transmitting, and distributing electricity, it could spur some marginal economic growth and employment. However, in times of near full-employment, which North Carolina is likely at or near to with its current unemployment rate of about 4.5%, there is often job reshuffling associated with new industries, whereby those taking jobs in relatively new sectors are leaving existing jobs, making it difficult to ascertain the direct and indirect employment effects of these new sectors.<sup>8</sup>

Significant job creation is a possibility if North Carolina becomes a hub for innovation in storage technology, attracting storage-related firms to the state. There is precedent for such a possibility. University-corporate collaborations have helped to establish North Carolina as a center for innovation in both biotechnology and smart grid technology. For example, the biotechnology cluster, which began to form decades ago in North Carolina, now supports over 600 life sciences companies employing more than 60,000 people. The resultant sustained industry growth – 31 percent since 2001 – brings billions of dollars of investment to the NC economy that could otherwise have gone to other urban educational centers around the country. More recently in the area of “smart grid” technologies, a quickly growing collection of power equipment companies like ABB, Schneider Electric, Sensus and Siemens, have joined with world-leading technology and data analytics firms, including IBM, Cisco, EMC, SAS, and Red Hat to form one of the largest U.S. clusters of companies creating innovative, intelligent energy infrastructure. Thus, one can envision job creation within North Carolina by leveraging our existing strengths in energy research and development and by creating market opportunities to attract storage firms to the state.

---

<sup>8</sup> For more information regarding the difficulties of estimating job impacts of new sectors within the energy field, see the following blog post from the Energy Institute at Haas, written by Severin Borenstein: <https://energyathaas.wordpress.com/2015/02/17/the-job-creation-shuffle/>.

## 9. Identification of Barriers and Policy Options

The following section evaluates barriers to energy storage and corresponding policy options as part of a coordinated statewide energy policy to maximize the value of storage to North Carolina consumers. As guided by our HB589 mandate, we began with a review of existing policies in North Carolina with the potential to affect energy storage. We then evaluate policy options to facilitate deployment of energy storage, drawing largely upon experience in other states. We conclude by leveraging our review of North Carolina provisions and options deployed elsewhere to recommended policy changes that may be considered to address a statewide coordinated energy storage policy in North Carolina. Throughout the analysis, we follow an organizational convention derived from the North Carolina Clean Energy Technology Center's *50 States of Grid Modernization* reports. These categories are modified slightly to better fit the specific focus of the analysis, and include the following:

- Analysis, R&D, and Market Support: Efforts to support research, technical development, and storage deployment, ranging from the present analysis, to initial technology development, to worker training programs.
- Planning and Access: Efforts to define, reform, or refine utility planning processes and/or the rules affecting access to everything from data to state or wholesale markets.
- Business Models and Rate Reform: Efforts to change how utilities are regulated or operate under a particular state or wholesale market. Can also consist of more targeted changes to rate design (e.g., time-of-use rates, demand charges).
- Mandates: Policies establishing minimum deployment targets or performance standards.
- Process and Approvals: Policies that govern the regulatory process for the deployment of storage (e.g., interconnection standards, compensation rules).
- Incentives and Financing: Policies that provide funding, defray cost, or provide an increased benefit related to storage deployment (e.g., loan programs, tax credits, rebates, exemptions).
- Utility-Driven Demonstrations and Deployment Programs: Utility-led programs to purchase, fund, or deploy storage. Note that the emphasis here is on *programs* for deployment, not individual installations themselves.

### 9.1 Overview of Current and Pending Provisions Affecting Storage in North Carolina

We began our review of existing energy storage policies in North Carolina with a review of key components of energy-related policy in the state. This included existing North Carolina Utilities Commission (NCUC) Rules and key energy-related legislation (e.g., Senate Bill 3, House Bill 589), as well as the regulations, rate cases, settlements, rulemakings, and/or orders that emerged as a result. In addition to state policies, we also reviewed policies or provisions explicitly referencing storage issued by PJM regulators or the Tennessee Valley Authority (TVA) because of their footprint in the state.

Next, we consulted third-party news alerts, policy briefs, issue analyses, and summary reports to identify provisions that our initial scan may have missed (e.g., AJP, 2016; CNEE, 2017; Endemann et al., 2018; Energy Storage Association, 2017; Stanfield et al., 2017). To the extent that any additional storage-related provisions were identified by these third-party sources, we again consulted

current dockets, rules, regulations, and/or statute to confirm their continued existence and relevance.

Despite our best efforts to fully and accurately characterize the energy storage policy landscape in North Carolina, the unique capabilities and operational considerations of energy storage, combined with the rapidly evolving nature of technology and its applications, make documentation of existing regulatory context difficult. In addition to state-level, storage-specific provisions that could affect the deployment of storage, standards and processes developed at scales that range from the local level (e.g., land use ordinances) to the national and international level (e.g., fire and safety codes) have the potential to affect the deployment of energy storage in the state. For this reason, we supplemented our own internal review of existing policy provisions with a survey distributed to the stakeholder group convened by the project team.

On August 27, 2018, the following anonymous survey was distributed via Google Forms to stakeholders who had provided their email addresses to us for the purposes of study communications and event notification:

*As an expert in your particular sector or industry, what existing or potential policies or programs have the greatest ability to influence energy storage in North Carolina? Please be specific, and give special consideration to state-level policies in North Carolina. Feel free to also note other policies with the potential to affect storage research, deployment, or operation in the state, even if they are operating at other scales or are implemented by non-state entities (local, regional, national, or international regulations, standards, or incentives; utility-driven programs, etc.).*

In total, we received eight (8) responses between the date the survey was distributed and September 17, 2018, when the form was closed; individual responses to the survey can be found in (Appendix D, Table D.1).

The results of each part of the review were organized into general policy types, again using a modified organizational approach to that used in the *50 States* reports. Owing to the rapid evolution of markets and policy relation to energy storage, the review below should not be considered to be exhaustive but rather indicative of provisions pending or in place as of October 24, 2018.

### **9.1.1 Analysis, R&D, and Market Support**

Previous analyses have noted that up to \$1 million for research and development, potentially including storage, is authorized for cost recovery under the North Carolina Renewable Energy and Energy Efficiency Portfolio Standard (REPS) (NGA, 2016). The authorizing statute is unclear in this regard (“Fund research that encourages the development of renewable energy, energy efficiency, or improved air quality, provided those costs do not exceed one million dollars (\$1,000,000) per year.” NC Gen. Stat. §62-133.8(h)(1)(b)), and at least one other third-party report specifically recommends that the provision be explicitly targeted and expanded to include large-scale storage (AJP, 2016). While potential relevance of this provision is reinforced by recent cost recovery filings that have included storage (e.g. Duke Energy Progress, 2018c), both Duke Energy Carolinas and Duke Energy Progress showed less than \$1 Million in total authorized research and development expenditures under the state REPS in their 2017 Compliance report filings (Duke Energy Carolinas, 2018b; Duke Energy Progress, 2018c).

### 9.1.2 Planning and Access

At the federal level and in regional transmission organizations (RTOs) such as PJM, Federal Energy Regulatory Commission (FERC) Order 841 is directly relevant to energy storage deployment and operation. The Order itself provides guidance to RTOs for incorporating storage into wholesale markets, and provides multiple stipulations on how this should be done (e.g., setting minimize size for participation, ensuring adequate technical capabilities). Other relevant FERC orders include Order 845 (revised the definition of a generating facility to include storage resources) and Orders 784, 819, and 890 (opened various ancillary service markets to non-generating resources). Within PJM itself, batteries and other storage assets are already eligible for participation in ancillary service (Reg D) markets.

At the state level, most of the planning provisions potentially applicable to storage appear to address the technology only indirectly. For example, NCUC Rule R8-41 (Emergency Load Reduction Plans and Emergency Procedures) requires demonstration of black start capabilities, which could conceivably include storage. Rule R8-60 (Integrated Resource Plannings and Filings) makes a generic call for load requirements and resource options, which again could conceivably include storage. Rule R8-60 also requires utilities to identify implications of smart grid deployment on planning, within which storage is explicitly mentioned, though requirements are generally limited to reporting of demand and energy impacts, anticipated effects on a given particular jurisdiction or customer class, and the plans for measuring and verifying those effects.

R8-60.1 (Smart Grid Technology Plans and Filings) outlines requirements for biennial smart grid plans. R9-60.1 does not specify which technologies should be considered, but rather requires that filed plans describe the technologies to be deployed, the goals and objectives of deployed technologies, the costs of those technologies, and the analyses relied upon by the utility to justify those technologies. Rules R8-68 (Incentive Programs) and R8-69 (Cost Recovery for DSM/EE Measures) generally define the process by which utility and electric cooperative energy efficiency and demand response/demand side management programs may be approved for use, as well as the process for cost recovery.

At present, transmission and distribution (T&D) as it would pertain to storage appears to be subsumed within the resource planning process. In addition to Smart Grid Planning (R8-60.1), there are also processes outlined in R8-61 regarding the approval and construction of transmission/substation facilities associated with new generation assets. Similar processes are outlined in R8-62 for stand-alone transmission assets. There do not appear to be provisions specifically targeted to storage, only a requirement that environmental impacts of new transmission assets be minimized or mitigated. At the federal level, FERC Order 1000 required non-wires alternatives, including storage, to be considered in planning processes on par with traditional transmission services.

In the most recent IRPs filed by both Duke Energy Carolinas and Duke Energy Progress, battery storage is explicitly considered within two of the identified representative portfolios analyzed by the utilities (Duke Energy Carolinas, 2018a; Duke Energy Progress, 2018b). Duke Energy Carolinas includes 150 MW of nameplate installed storage in its base case scenario, whereas Duke Energy Progress includes 140MW of nameplate installed storage. Both utilities also include storage

integration as part of their short-term action plan, with Duke showing 60 MW and Progress showing 64MW of planned storage additions between 2019 and 2023. The IRPs also discuss a shift to Integrated System and Operations Planning (ISOP) to better capture the role of emerging technologies like battery storage in generation, transmission, and distribution.

### 9.1.3 Business Models and Rate Reform

In its 2017 avoided cost ruling (Docket No. E-100, SUB 148), the NCUC signaled an intention to refine avoided cost calculations so as to provide clearer signals to qualifying facilities to further facilitate the deployment of advanced solar (i.e., tracking) or storage applications, largely by reducing the number of on-peak hours while increasing rates paid. In its June 22, 2018 rate case Order (Docket No. E-7, SUB 1146), the NCUC ordered Duke Energy Carolinas to file new time-of-use (TOU), peak, and other dynamic rate types within six months to assist customers in reducing energy, generally, and peak consumption, specifically (p331, para 29). The influence of evaluation criteria on the selection of solar+storage versus solar-only projects in the context of the Competitive Procurement of Renewable Energy (CPRE) program has also been highlighted by the Public Staff (NCUC, 2018).

Though HB589 (NC Gen. Stat. §GS 62-126.4) initiated a process for reconsideration of net-metering rates, the July 6, 2006 NCUC order under Docket No. E-100, SUB 83, particularly regarding net-metering, TOU rates, and prohibition against “gaming” (i.e., use of off-peak generation to offset higher-valued on-peak consumption), appears to remain relevant to storage:

*“[T]he Commission shall require the utilities to modify their net metering tariffs and riders to eliminate the prohibition on batteries. However, the Commission will continue to prohibit net metering customers from using batteries for gaming, or abusing the time-of-use restrictions, by offsetting more valuable on-peak consumption with less valuable off-peak generation. Utilities may raise specific concerns with the Commission if they believe that such gaming or abuse becomes a problem in general or in specific instances. Any customer found to be engaged in such practice shall be banned from net metering.” (p7)*

Rates specifically targeted to storage have been offered in the past in North Carolina (see, e.g., a long-closed schedule for residential electric thermal offered by Blue Ridge Energy: <https://www.blueridgeenergy.com/residential/help-faqs/electric/understanding-my-bill/rate-schedules>; last accessed September 24, 2018), but they do not appear to be common at present. Text from a recent third-party report would seem to support this conclusion (“[P]articipants noted grid-wide adoption of energy storage would be advanced by a rate design that would encourage its deployment.” NCSEA, 2016; p4).

Regarding ownership and leasing, HB589 (NC Gen. Stat. §GS 62-126.5-.7 and .9) authorized up to 250 MW of leased generation, with attending clarification that lessors are not public utilities. It is unclear how this would pertain to storage assets. There are examples of microgrid projects under various electric cooperatives in which assets appear to be shared between the co-op and end user (see, e.g., NC Electric Cooperatives, 2018), though again it is unclear what these examples imply for storage ownership options in the state, more generally.

#### 9.1.4 Mandates

The team has not identified any North Carolina storage-specific mandates as defined by this analysis. Though municipal utilities and electric cooperatives can employ demand side management for REPS compliance (NC Gen. Stat. §62-133.8(c)(2)(b)), it is unclear as to the role storage specifically can play in satisfying existing regulatory obligations.

#### 9.1.5 Process and Approvals

NC Gen. Stat. § 62-110.1(a) requires that the NCUC issue a Certificate of Public Convenience and Necessity (CPCN) prior to construction of a “facility for the generation of electricity”. As suggested by a recent CPCN application filed by Duke Energy Progress for the Hot Springs Microgrid Solar and Battery Storage Facility (Duke Energy Progress, 2018a), however, battery storage systems may themselves be considered under current interpretations of the statute to fall outside this definition (i.e., not generation). This has the potential to create confusion or uncertainty depending on the particular use a storage system is anticipated to fulfill.

Also relevant to this category are May 2015 interconnection standards (Docket No. E-100 Sub 101), specifying that storage may be connected to the grid under the same process as other small generating facilities. The process for revisions to interconnection standards are ongoing under this same docket, with multiple provisions related to storage being debated under the auspices of the proposed CPRE program.

At the county and municipal level, decisions regarding contracting, zoning, compliance with fire codes, and decommissioning requirements are likely to affect deployment and operation of storage. Though experiences with solar are potentially informative of the general processes the installation of storage will undergo, there are also likely to be specific issues faced by storage applications that are both unique to the technology and continually evolving (e.g., fire codes and decommissioning procedures).

#### 9.1.6 Incentives

The analysis has not identified any North Carolina-specific incentives as defined by this analysis.

#### 9.1.7 Utility-Driven Demonstrations and Deployment Programs

Though there are a number of energy storage projects underway in North Carolina (Figure 2.2), the intent of this section is to identify broader utility-driven programs for storage deployment, and not single installations. As discussed above under “Planning and Access”, the most recent IRPs filed by Duke Energy Carolinas and Duke Energy Progress review a number of planned storage installations and changes to planning processes to better capture the role of emerging technologies like storage. In addition to the Duke Energy Progress Hot Springs microgrid project referenced above, the company has begun development of a battery storage project in Asheville, NC as part of its Western Carolinas Modernization Plan (Duke Energy Progress, 2018b; <https://www.utilitydive.com/news/duke-energy-to-spend-500m-on-battery-storage-in-next-15-years/539385/>; last accessed October 26, 2018) and has also installed a solar+storage project utilizing a zinc-air battery in the Great Smoky Mountains National Park so as to support a Park Service communications tower and defer future system upgrades (Duke Energy Progress, 2018b; Duke Energy Progress, 2018d). In 2014, Dominion Energy installed a microgrid demonstration and



study project in Kitty Hawk, NC, consisting of a 25kW battery, microwind turbines, fuel cells, solar array, and associated control technologies and monitoring systems (Dominion Energy, 2017b); a final study report on the project was filed with the NCUC in 2017 (Dominion Energy, 2017a).

Elsewhere, initial filings under the Duke Energy CPRE program discussed a modified power purchase agreement (PPA) to allow for pre-inverter storage (i.e., not dispatched by Duke Energy; See DEC & DEP, 2018). Storage can only be included as part of a renewable project proposal; there is no apparent provision for stand-alone storage. Finally, there are examples of storage deployment by individual municipal utilities or electric cooperatives, such as the aforementioned electric cooperatives microgrid projects (<https://www.ncelectriccooperatives.com/energy-innovation/microgrids/>; last accessed September 24, 2018), as well as a recent request for qualifications for a solar+storage project issued by the Fayetteville Public Works Commission ([http://www.faypwc.com/wp-content/uploads/2015/06/bid-rfq-design-build-services-community-solar-energy-storage-project\\_101717.pdf](http://www.faypwc.com/wp-content/uploads/2015/06/bid-rfq-design-build-services-community-solar-energy-storage-project_101717.pdf); last accessed September 27, 2018). Broader municipal or electric cooperative programs to facilitate storage deployment were not identified by this review.

## 9.2 Overview of Policy Options to Facilitate Deployment of Energy Storage

Our review of state policies and initiatives began with a review of state-level energy storage studies similar to that mandated by HB589. Using the 50 States of Grid Modernization Q1 2018 (NCCETC, 2018) report as our foundation, we reviewed reports issued by California, Connecticut, Maine, Maryland, Massachusetts, Michigan, Minnesota, Missouri, Nevada, New York, and Vermont. Additionally, we reviewed third-party reports focused on specific states and energy storage deployment opportunities or challenges; a list of sources cited herein can be found at the end of the chapter, along with a list of further reading materials that were not cited directly but were nonetheless found to be relevant. These documents and reports provided a thorough characterization of the energy storage policy landscape across states, and in doing so, helped to highlight policy options that North Carolina might consider for inclusion in statewide coordinated energy storage policy.

Owing to the variety and complexity of state-level energy storage governance, our review focused on policies explicitly referencing energy storage. For example, a given policy was included in our review if energy storage was directly cited in the docket, order, plan, regulation, bill, or statute. Policies pertaining to issues like advanced metering infrastructure or data access were not separately considered if energy storage was not directly mentioned, even though policies such as these could ultimately play a role in, for example, increasing behind-the-meter (BTM) energy storage deployment. The review should thus be considered indicative, but not exhaustive. Owing to the rapid evolution of the energy storage policy landscape, the review should also be seen as representing a snapshot in time, reflecting sources available and reviewed as of October 24, 2018.

Having identified a list of state policy options, we then characterized each by a series of attributes to aid in determining the potential relevance or fit within a North Carolina statewide energy storage policy context. We noted whether each policy was found in states with vertically-integrated or restructured electricity markets (defined loosely as the presence of retail choice programs in a given state), whether they fell within the Southeast electric power market or PJM, whether providers with a North Carolina footprint (Duke, Dominion, Tennessee Valley Authority) served as an energy provider in the state, and whether the state required the filing of integrated resource plans (IRPs) or

other similar planning document as part of the regulatory process. We also included the current proportion of generation assets in the state. The combined table can be found in Appendix F.

### **9.2.1 Factors Influencing Energy Storage Deployment**

Though the sources reviewed here often explored factors influencing the deployment of energy storage in the context of individual state or wholesale markets, the conclusions reached were generally consistent. Specifically identified in the literature, third-party summary reports, and case studies were the three primary categories of factors: cost competitiveness, an equitable and established regulatory environment, and acceptance of the technology by industry, regulators, and other affected stakeholders. Not all factors were equally applicable in all places or with regard to all technologies or applications. Furthermore, the most important factors influencing energy storage may also vary from stakeholder to stakeholder (MDER et al., 2016).

#### ***Cost Competitiveness***

Sources consulted here suggest that energy storage often requires consideration of the multiple services storage provides to be cost competitive (NGA, 2016). Furthermore, storage may not be eligible for existing financial incentives, nor may it be eligible to participate in every potential market in which it could theoretically do so (NGA, 2016). In addition to the installed cost of energy storage, Endemann et al. (2018) note how storage applications may also require more routine management to address changing circumstances and service provision to the grid, potentially further increasing costs. Endemann et al. (2018) also cite uncertainty around the eligibility for specific revenue streams in the face of rapidly changing regulations and markets. This conclusion is echoed by Bhatnagar et al. (2013), who note that market access is limited in some areas due to outdated compensation mechanisms, or even a complete lack of markets for particular services, as well as lack of access to information on prices for ancillary services, particularly in vertically-integrated states. A difficulty in valuing services provided by storage is likewise cited by Bhatnagar and Loose (2012).

In the context of other state-level reports or analyses, NY-BEST (2016) describes an inability to access or monetize the full value of storage in NYISO markets, as well as a lack of incentives and financing opportunities and high transaction costs. In the state of Maryland, costs are likewise mentioned, as is the difficulty of quantifying the value and monetizing the services provided by storage, an incompatible rate design, and continued linkage of utility profits to asset investment (MDNR 2017a, b). A 2014 California energy storage roadmap cited an inability to capture the full suite of revenue streams potentially generated by storage, and a need to reduce the cost of deployment (i.e., interconnection) and operations (California ISO et al., 2014).

#### ***Established Regulatory Environment***

As Winfield et al. (2018) note, “[i]n monopoly regimes, the pathway to adoption into a regime is relatively direct, but largely at the discretion of the monopoly utility” (582). Information asymmetries between utilities and both regulators and third-party developers in vertically-integrated states can make deployment of front-of-meter applications challenging (Stanfield et al. 2017). These sentiments are further encapsulated in recent comments issued by the Public Staff at the North Carolina Utilities Commission in response to documents filed under the CPRE docket:

*Incorporating energy storage into the CPRE Program is a complex and technical concept, made even more difficult in North Carolina's vertically integrated market where ancillary services do not have separate markets into which independent power producers can bid their energy storage resources. (NCUC 2018; p5, para7)*

Elsewhere, concerns were specifically being raised as early as 2012 regarding the definition and classification of storage (e.g., generation, transmission, distribution), uncertainty over national (i.e., FERC) and state public utility commission jurisdiction, and potential tradeoffs between encouraging deployment through mandates and resulting system efficiency (Bhatnagar and Loose 2012). More recent assessments identified regulatory procedures like interconnection, local siting requirements, and fire codes as being either difficult to navigate or otherwise ill-suited to the unique attributes of storage and storage technologies (NGA 2016).

The above issues have been borne out further in individual state assessments. In their review of experience with energy storage deployment in Colorado, New Jersey, Texas, and Wisconsin, for example, Bhatnagar et al. (2013) discuss the difficulties presented by outdated regulatory procedures and requirements that do not address the unique characteristics of energy storage. Stakeholders in the California energy storage roadmapping process identified a need for regulatory and process certainty (California ISO et al., 2014). A 2016 New York energy storage roadmap (NY-BEST, 2016) specifically cites barriers created by an absence of standardized energy storage safety regulations. A recent Missouri Public Service Commission Staff Report on broader issues emerging in utility regulation identified questions of utility ownership of storage, particularly challenges of transmission and distribution utility ownership should storage be classified as generation, as well as the ability of utilities to access BTM capacity (MPSC 2018). In Maryland, issues of ownership and interconnection have been specifically identified as examples of outdated or incompatible regulatory processes (MDNR 2017a, b).

### ***Technology Acceptance***

Technology acceptance is both a function of the emerging nature of the technology and its various use applications. For example, previous analyses cite the role of utility, consumer, and investor confidence in energy storage applications (NY-BEST, 2016; U.S. Department of Energy, 2013) and a need for validation of both safety and reliability (U.S. Department of Energy, 2013). Similarly, there has been an expansion in the availability of information on storage technology and its applications, but there remains a lack of general awareness of energy storage capabilities, as well as a specific lack of modeling capacity to assess storage economics and contributions (Bhatnagar et al., 2013). Such information gaps are among a variety of other cost and regulatory barriers cited in recent updates released as part of a continuing energy storage study effort in the state of Maryland (MDNR 2017a, b).

Our review in Section 9.1 above suggests that there are few policies or programs in the state specifically targeted to storage but several that are potentially applicable to storage. Though current interconnection provisions reflect potential storage use cases, many other aspects of North Carolina state policy do not explicitly consider energy storage applications. This gap is not unexpected or surprising, given the emerging nature of the technology and the frequency with which uncertain or incompatible regulations are cited as barriers in other states. Ledford (2015) reached a similar conclusion, noting that several of the barriers reviewed therein were “universal in nature and affect

North Carolina as they would any other jurisdiction” (p15), including issues of cost, performance, industry acceptance, an ability to evaluate potential and monetize value, and the presence of incompatible market and business models.

Responses to an anonymous, self-selected survey distributed to the stakeholder group identified a few specific barriers to energy storage in the state. In the eight responses that were received, stakeholders generally suggested that storage provisions in nascent procurement programs were overly restrictive, that insufficient consideration was being given to non-wires alternatives, the continued existence of ambiguity or uncertainty with regulatory approval processes for energy storage, and a need to better integrate storage into existing modeling and planning efforts, particularly as it occurs in the context of utility IRPs (Appendix D, Table D.1). A subsequent request for comment on a draft review of North Carolina policy provisions likewise elicited comments on other provisions with the potential to affect storage in the state, including a lack of ancillary service markets, definitional uncertainty, an absence of storage-specific rates and business models, and the role of local permitting processes and tax policies (Appendix D, Table D.2).

### 9.2.2 Policies Relevant to Energy Storage Deployment

The sources reviewed here identify a variety of areas in which policy or regulatory reform can influence the deployment of energy storage. These policy examples provide a basis from which to draw should the further deployment of energy storage be found to add value for North Carolina consumers. For example, ESA (2017) specifically emphasizes three separate classes of policy options: *value* (including the availability of incentives, financing, and appropriate rate design); *competition* (including procurement and planning processes, non-wire alternatives programs); and *access* (including interconnection, ownership options, and multi-service capabilities/stacking). Winfield et al. (2018) similarly identify three general categories of policies to encourage the further deployment of storage across a variety of market and national and subnational contexts: remove barriers to market participation; allow storage to participate in multiple markets; and create new market participation models (e.g., aggregators of BTM storage). Hart et al. (2018) meanwhile provide general policy guidance to states, specifically that they include deployment targets (including subtargets for different storage technologies), work with regional transmission organizations (RTOs) as necessary to revise rules allowing storage to participate in markets, encourage storage deployment through planning processes (i.e., integrated resource planning), and implement innovative rates structures.

The individual policies identified in our review can be further categorized into three overarching policy objectives consistent with the factors discussed above: establish a consistent and compatible regulatory environment, improve cost competitiveness, and promote technology acceptance. There is a great deal of overlap between the types of policies potentially included under each, but the aggregation is nonetheless helpful to highlight commonalities between the basic outcome the individual measures are trying to achieve. A list of policy types most applicable to each objective is also provided to help link the discussion here to our survey of state policies to facilitate energy storage (Appendix F); these are noted under “Policy Categories Included” at the end of each subsection. Note that the summary provided immediately below and the list of state policies provided in Appendix F merely recount the findings, experience, and recommendations as provided by existing analyses and reports; they do not necessarily reflect specific policy recommendations for

the development of statewide energy policy in North Carolina. North Carolina—specific recommendations based upon the technical, economic, and policy analysis conducted herein can be found in Section 9.4.

### ***Establish a Consistent and Compatible Regulatory Environment***

Multiple sources suggest that energy storage can be facilitated by a regulatory environment that includes technology-neutral monetizing mechanisms and standards for siting, performance, integration, and procurement (U.S. Department of Energy, 2013; Endemann et al., 2018). This could entail development of regulatory processes for interconnection that specifically consider energy storage, potentially even offering a separate, expedited or reduced-burden requirements for non-exporting systems (NGA 2016; Stanfield et al. 2017). Another recurrent element in the literature is the need for planning processes to evaluate the role of storage, including the detailing of specific valuation methods, the process for ensuring consideration of non-wires alternatives, and the sharing of hosting capacity analyses to identify areas for storage interconnection (NGA 2016; Stanfield et al. 2017). Also important is consideration of how to link energy storage to other pre-existing planning efforts, programs, or objectives. The incorporation of storage into resiliency or energy assurance plans is one particular area discussed in the literature (NGA, 2016). Another consideration discussed in the literature is how to link storage to state renewable portfolio standard (RPS) programs, particularly the mechanisms by which renewable energy certificates (RECs) are issued (e.g., Holt and Olinsky-Paul 2014). To the extent that established regulations create value for various storage applications or services, there is inherent overlap with the second category below (“Improve Cost Competitiveness”).

Policy Categories Included: Analysis, R&D, & Market Support; Planning & Access; Business Model & Rate Reform; Mandates; Process & Approvals

### ***Improve Cost Competitiveness***

This category includes direct financial incentives, such as direct grants or tax incentives. It could also include the creation of markets or other mechanisms to generate value for storage systems, such as time-of-use or other favorable rate structures, or other price signals such as demand charges, demand reduction auctions, or other incentives for customer or BTM systems (Stanfield et al. 2017). The category could further include various financing approaches to specifically support the installation and operation of storage (see, e.g., Endemann et al. 2018), or energy regulations that recognize and/or help to monetize the multiple services provided by energy storage (U.S. Department of Energy, 2013; NGA, 2016). Likewise important is clarification of ownership and how storage is classified for the purposes of transmission and distribution cost recovery (Stanfield et al. 2017). The use of procurement targets to create certainty for future capacity demand is likewise discussed in the literature (e.g., NGA, 2016), as are the complexities of establishing such a target, particularly as it pertains to uncertainties surrounding future cost declines and whether to set restrictions about minimum and maximum deployment (Hledik et al. 2018). In these respects, there is a great deal of overlap with the previous category (“Establish a Consistent and Compatible Regulatory Environment”).

Policy Categories Included: Analysis, R&D, & Market Support; Planning & Access, Business Model & Rate Reform; Process & Approvals; Incentives & Financing; Utility-Driven Demonstrations

### ***Promote Technology Acceptance***

This policy objective can be partially addressed through efforts to establish a consistent regulatory environment and to improve cost competitiveness. More targeted efforts include research and development funding, public-private partnerships, and demonstration projects (e.g., NGA, 2016). Also important is the development of safety standards and operational and decommissioning procedures to guide storage siting, approval, and use (U.S. Department of Energy, 2013; NGA, 2016). Development of these standards and procedures is seen as a priority area in some markets. For example, a recent New York storage roadmap (NY-BEST, 2016) identified addressing an absence of standardized safety regulations as the most immediate of short-term goals, preceding even modification of wholesale market rules.

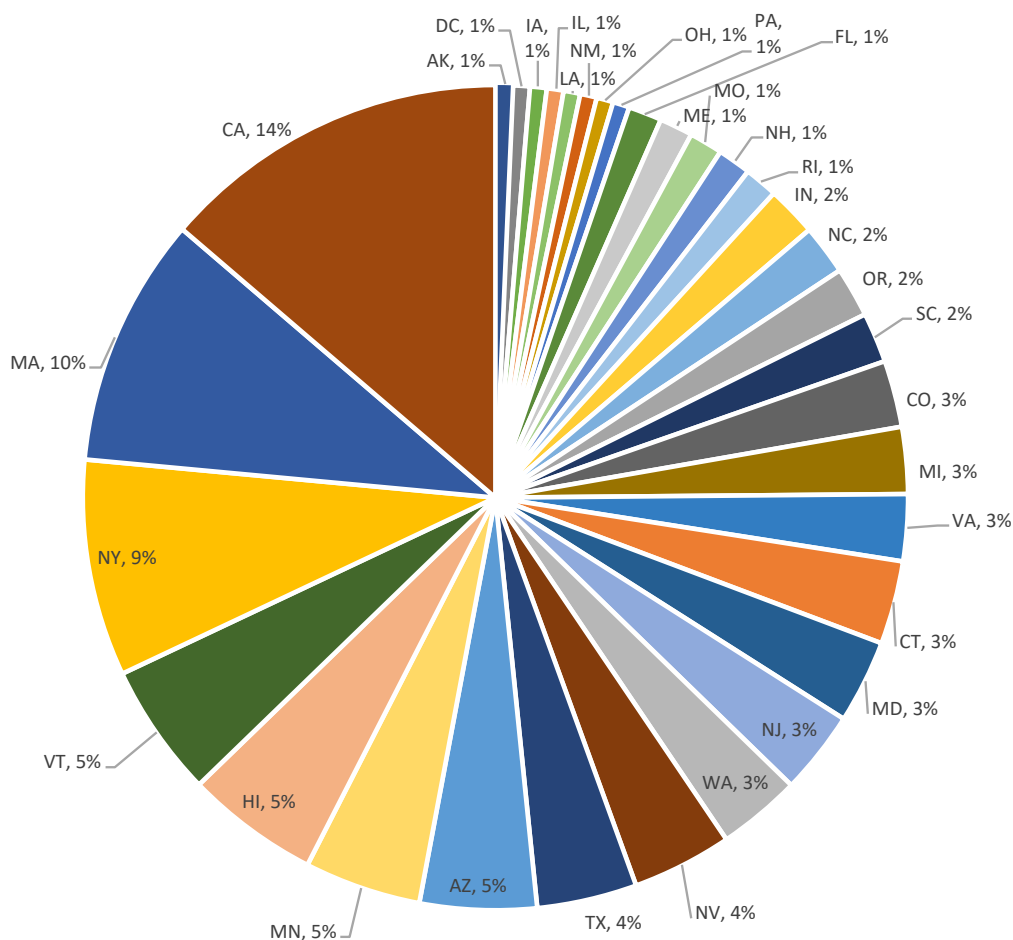
Policy Categories Included: Analysis, R&D, & Market Support; Planning & Access; Process & Approvals; Utility-Driven Demonstrations

As above, there is a great deal of policy category overlap between the above objectives. For example, research and development can also lower the costs of future storage installation and operation. Clarification of regulatory provisions can reduce transaction costs, again reducing the total costs of installation and operation. Alternatively, establishment of long-term procurement targets or clarification of eligibility for certain value streams can increase the certainty of future income and potentially allow for greater costs to be tolerated at the outset.

### **9.2.3 Recent Energy Storage Policy Experience in Other States**

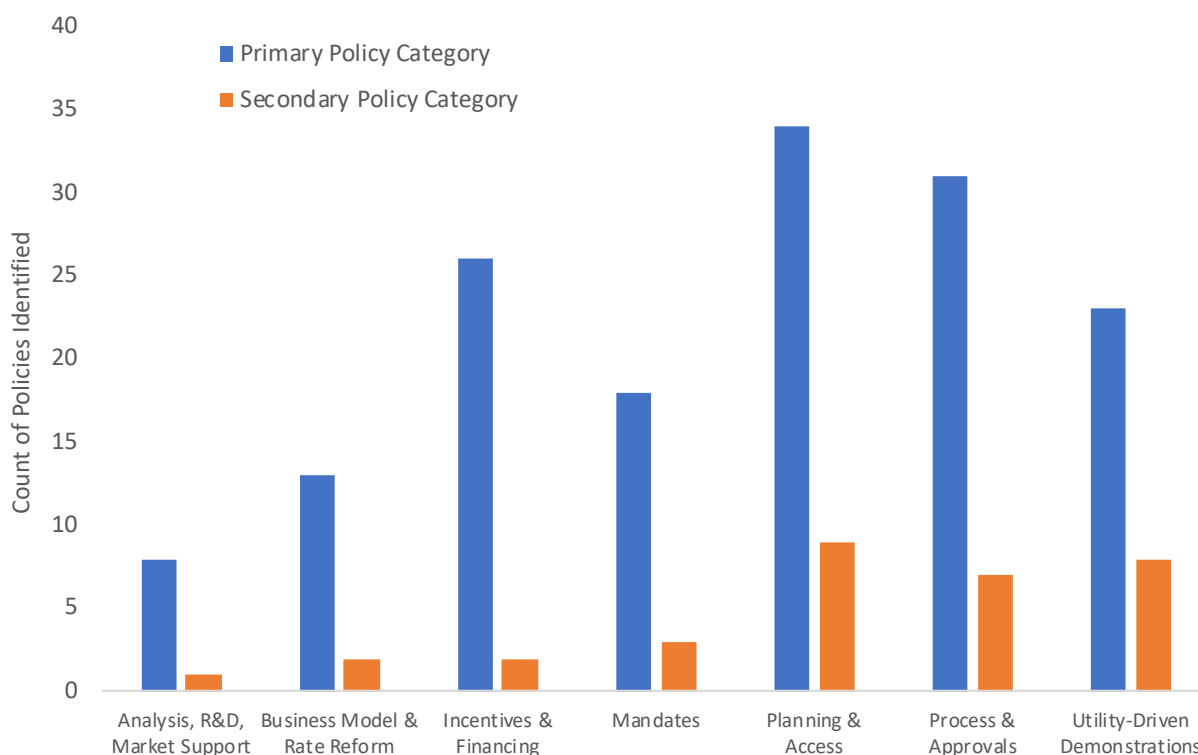
As Stanfield et al. (2017) suggest, states considering mechanisms to facilitate energy storage “should leverage other states’ experience with storage, as well as the growing body of reputable evidence about energy storage, to avoid more time- and resource-intensive exploratory steps” (p27). For this reason, we endeavored to develop, if not a comprehensive, at least an indicative assessment of existing state energy storage policy interventions to-date. A list of policies proposed or implemented by U.S. states regarding energy storage is provided in Appendix F, organized by the coding structure detailed in Appendix E. In addition to a general description of each state policy, Appendix F also includes the general category of policy type, again using a modified version of the organizational approach developed under the *50 States of Grid Modernization* report series. Also detailed is a series of planning, regulatory, and resource attributes that can help to determine the potential relevance or fit within a North Carolina statewide energy policy context.

In aggregate, the policies reviewed in Appendix F are themselves indicative of certain trends. First is geography. States seen as leaders or first-movers in energy storage—California, Massachusetts, New York—also contribute a higher proportion of documented policies (Figure 9.1). Several other states—Hawaii, Vermont, Minnesota, Arizona, Texas, and Nevada—also contribute a relatively higher proportion of policies than most other states. Many of these states—California, Hawaii, and Arizona, and Texas in particular—are also leaders in terms of installed capacity (Section 2).



**Figure 9.1.** Proportion of total policies identified, by state.

A second observation of the aggregate listing of state policies is the distribution across policy type. Looking only at primary policy categories as discussed in the introduction to this section and detailed further in Appendix E, Planning & Access and Process & Approvals comprise a majority of policies documented here (Figure 9.2). This is not surprising given the emerging nature of the technology and the above-mentioned challenges energy storage has faced in integration with existing planning processes and regulations. Incentives and demonstrations likewise make up a large proportion of total policies, again stemming from the emerging nature of the technology and its applications.



**Figure 9.2.** Count of total policies identified, by primary and secondary policy category.

### 9.3 Previous Energy Storage Policy Conclusions Relevant to North Carolina

There have been numerous reports issued either in the context of state energy studies or conducted by third-parties to help inform policy deliberations. Though the findings and recommendations from these various analyses are discussed throughout this section, a subset are of particular interest to North Carolina owing either to their particular market context, their geographic proximity, or the barriers they are seeking to address. VDPS (2017), for example, offers multiple recommendations to encourage the deployment of storage in Vermont, a vertically-integrated state. Specifically, they recommend the adoption of guidance documents to inform integrated resource plan (IRP) consideration of storage, the institution of time or geographically variable rates, amendment of regulatory review procedures and interconnection standards (including streamlined processes for small projects), and amendment of existing incentive programs to include storage. Procurement targets were mentioned as receiving both support and opposition by various stakeholders.

Energy Transition Lab (2017) discusses several policy interventions or demonstration and pilot project initiatives that could be implemented in Minnesota, another vertically-integrated state. In that report, the authors specifically cite clarification of cost recovery provisions for storage, clarification that future capacity requirements be technology neutral, a need to update the tools and processes for evaluating storage in the context of integrated resource planning, and development of supportive rate structures. Recent study updates issued from the restructured state of Maryland provide alternative perspectives from a regionally-proximate PJM market state. In the context of their state energy study, stakeholder support was identified for mandates and procurement targets, various rate



reforms, pilot projects (MDNR, 2017b). Support was also implied for incentives and technology-neutral approaches.

Though the above analyses may have some relevance to the development of energy storage policy in North Carolina, our review identified very few sources with recommendations specific to the state. Those that were identified are briefly reviewed below. Note that discussion of these sources does not indicate endorsement of their findings or the recommendations they offer. Rather, they should be seen as a useful data point on perceived gaps and suggested policy solutions as held by various stakeholders participating in energy storage policy deliberations.

Ledford (2015) describes the barriers facing storage in North Carolina, citing many of the same specific types reviewed above (e.g., industry acceptance, validated performance, inability to monetize value). Issues of jurisdictional conflict and storage classification are also noted as being less an issue in the state than they might be in other areas of the country owing to the minimal footprint of wholesale markets. As for recommended policy solutions, Ledford (2015) suggests that regulators coordinate oversight to minimize regulatory conflicts and that residential rate designs be reformed to provide increased incentives for battery installation and use. Also noted is the role of NCUC in creating a market for ancillary services, specifically by requiring utilities to compensate third parties for the services provided.

In their review of emerging energy issues in the state, The Center for a New Energy Economy (CNEE, 2017) offers several recommendations to encourage energy storage in North Carolina. On the regulatory front, they suggest extending interconnection rules to municipal utilities and co-ops, requiring consideration of energy storage for the purposes of both supply and demand management, and providing data access to facilitate third-party developer supply of storage-related services. With regard to financing, they recommend incentives for BTM storage, either directly or through authorization of utility-offered programs, incentives for storage-facilitated reliability and micro-grid applications, and financing for commercial BTM applications to reduce demand charges.

In its recommendations to increase energy storage in the state, AJP (2016) suggests that the NCUC develop a process for the valuation of storage-related services and to include assessment of storage in utility IRPs. They also recommend increased data transparency, specifically that utilities disclose prices on a sub-hourly basis. Finally, they recommend that cost recovery provisions be extended to include the leasing of storage capacity.

#### **9.4 Development of a Statewide Coordinated Energy Storage Policy in North Carolina**

The menu of recommendations we provide below should be seen as a starting point for further deliberations between stakeholders and decision-makers in the development of a statewide coordinated energy storage policy. Our recommendations can be categorized into three separate categories roughly corresponding to the magnitude of intervention: Prepare, Facilitate, and Accelerate. “Prepare” includes potential changes to existing policy that may help stakeholders and decision-makers plan for the near-term economical deployment and operation of energy storage. “Facilitate” includes interventions that stakeholders and decision-makers may consider if there is a desire to promote market transparency for particular uses or to better capture or monetize value streams provided by energy storage. “Accelerate” includes interventions that stakeholders and decision-makers may consider if there is a desire to advance the pace of energy storage deployment

beyond what might otherwise occur in the timeline and under the conditions assessed in this study. These categories are not necessarily mutually exclusive, nor do we judge the relative merit of the options within each category, but careful consideration should be given to interactions or trade-offs between any particular subset of selected options, as well as the sequencing thereof. For example, it would be inefficient to consider policy options that seek to accelerate storage deployment without first considering actions that clarify the treatment of storage under existing regulations.

Within each policy category are a series of specific policy recommendations, bolded for emphasis. Following each bolded recommendation is a discussion identifying potential policy elements that may be considered, as well as examples from other states where such policies or elements have been proposed or implemented. These discussions are intended to provide additional context to the policy recommendations and to provide a basis for informed discussions among stakeholders. Greater information on the referenced state examples can be found in Appendix F and the cited sources listed there.

Though the sheer number of potential policy options prevents an in-depth analysis of each example, we note at the outset that lessons drawn from other states require careful consideration to ensure applicability in the context of the North Carolina system. Many states from which policy examples are drawn are markedly different from North Carolina, particularly in terms of geography, regulatory and market structure, and resource mix. Inclusion of policy examples from these states is nonetheless informative as to the full range of policies being considered at present.

Finally, the complexity of the current policy environment also makes it difficult to determine the incremental effect of any of the below policy options on storage deployment or realized savings to either utilities or their customers. Furthermore, the general recommendations speak only to general types of policies. Experience in other states shows that the *details* of each program, ranging from program scope, to timing, to magnitude, to the process by which decisions are made, are of particular importance. Stakeholders and decision-makers are advised to carefully evaluate the implications of any of the below options—and the subsequent design and implementation of those options—on the particular regulatory and market context in North Carolina.

#### 9.4.1 Prepare

The technical and economic analyses conducted here suggest that some energy storage applications may already be cost-effective or soon will be. This conclusion is bolstered by the simple fact that a variety of energy storage projects have already been deployed or proposed in regulatory filings (Dominion Energy, 2017b; Duke Energy Carolinas, 2018a; Duke Energy Progress, 2018b; Duke Energy Progress, 2018d). As described in Sections 9.1-9.3, however, existing regulatory processes may not fully appreciate or accommodate the variety of uses and services potentially provided by energy storage. The following recommendations are provided for consideration if stakeholders and decision-makers are interested in addressing potential gaps or areas of uncertainty that might otherwise hinder the deployment of cost-effective energy storage in the state.

- **Update and Clarify Planning Provisions:** Most of the planning requirements potentially applicable to storage in North Carolina appear to address the technology only indirectly. One approach adopted in several other states is to explicitly require a full and transparent analysis of storage resources in the planning process. It is important to note that storage is included in recent IRPs filed by Duke Energy Carolinas and Duke Energy Progress (Duke Energy Carolinas,

2018a; Duke Energy Progress, 2018b). As our report suggests, however, analysis results can be sensitive to the assumptions employed, for example the capacity credit assigned to storage. Explicit reporting and analysis requirements pertaining to storage could thus help to establish consistency and transparency in the planning process. For example, a requirement that storage be given appropriate consideration as a generation and/or T&D asset can be found in recent filings and/or proposals in Minnesota (HF 3114 and SF 2710, February 2018), Missouri (see, e.g., 2015 PSC KCP&L decision), and New Mexico (see, e.g., February 2017 PRC rulemaking), three vertically-integrated states with IRP filing requirements. Alternatively, Washington (a vertically-integrated state with IRP filing requirements) calls for supporting analyses to utilize up-to-date, objective cost data and to employ sub-hourly modeling (Proceedings UE-151069 [2015] and U-161024 [2016]). Also relevant to consider is how storage is addressed under new or evolving planning processes in North Carolina (e.g., Integrated System and Operations Planning). While integrated system planning processes allow for evaluation of opportunities for non-wires alternatives, whereby energy storage may defer, mitigate, or obviate the need for investments in traditional T&D infrastructure, consideration should be given to how such processes are bound by or specifically link back to IRP requirements, particularly as it pertains to applications like storage that can serve as both generation and T&D assets.

- **Update and Clarify Definition and Ownership of Storage:** A recurrent challenge to the deployment of storage has been definitional uncertainty, particularly whether energy storage (and potentially associated microgrids) are considered to be a generation asset, a T&D asset, or either depending on their application (Bhatnagar and Loose, 2012; See also recent filings and/or proposals in vertically-integrated states such as Virginia, Vermont, and Iowa and restructured states such as California and Texas). Though it appears that storage is not currently considered to be a “facility for the generation of electricity” for the purposes of CPCN applications pursuant to NC Gen. Stat. §62-110.1 and Rule R8-60.1 (see, e.g., Duke Energy Progress, 2018a), explicitly clarifying the allowable roles that storage may play in the context of existing regulatory processes may help to avoid future uncertainty. Potentially stemming from this uncertainty, feedback from numerous stakeholder classes suggests that contractual limits on self-generation in supply contracts between generation utilities and municipal utilities and electric cooperatives may influence the configuration of storage projects undertaken by these utilities or in their territories. Elsewhere, third-party reports suggest that questions of ownership, particularly pertaining to cost recovery of leased capacity, may also warrant clarification (e.g., AJP, 2016).
- **Evaluate Net Metering Rules in Relation to the Utilization of Storage:** Several states are evaluating the eligibility of renewable energy systems paired with energy storage to net meter. Currently, such systems are not eligible for net metering in North Carolina. An approach under consideration in other jurisdictions is to allow systems configured to only allow export of stored electricity generated by the associated renewable energy system to participate in net metering. For example, a proposal under consideration in California would allow solar systems paired with battery storage to net meter as long as the project is configured such that the battery does not charge from the grid (Docket No. R14-07-002).
- **Update Interconnection Rules:** Existing interconnection standards in North Carolina already consider the potential for energy storage. As noted above, potential revisions to interconnection standards are underway, with multiple provisions related to storage being debated under the auspices of the proposed CPRE program. In addition to those proceedings, stakeholders and decision-makers should also continue to monitor the development of interconnection-relevant codes and standards, many of which are in various stages of development today, from the key

relevant codes organizations - IEEE, UL and NFPA (the National Fire Protection Association, which manages the National Electrical Code or NEC). As standards are finalized or achieve some level of consensus across the industry, formal adoption can help to set standardized rules for interconnection, much the way that UL 1741, IEEE 1547, and NEC 690 did for solar, thus enabling deployment (See, e.g., U.S. Department of Energy, 2013).

- **Provide Guidance for the Updating and Adoption of Relevant Local Codes and Permitting Standards:** In addition to the role of state and potentially federal policy in energy storage project deployment and operation, individual energy storage projects are also likely to require oversight and approval at the local (i.e., county, city, municipal) level. As storage becomes more prevalent, local policymakers may need additional guidance on how these technologies fit into existing zoning, permitting, building codes, decommissioning discussions, and other areas of local jurisdiction. An analysis of the specific local provisions with the potential to affect energy storage in the state was beyond the scope of this analysis, but would nonetheless be helpful in further appreciating the barriers and opportunities for storage deployment. For solar, numerous educational resources and model guidelines regarding zoning and development have been created and promoted through state agencies and local government associations as a starting point for discussions that ultimately become local decisions. Similar resources should be considered to provide local policymakers basic information on the potential issues associated with local deployment of storage technologies.

#### 9.4.2 Facilitate

The technical and economic analyses conducted here suggest that a variety of energy storage applications could become cost-effective between now and 2030. Experience within North Carolina suggests that utilities are already deploying energy storage pilot projects for the purposes of testing, research and development, and system reliability (Dominion Energy, 2017a; Duke Energy Carolinas, 2018b; Duke Energy Progress, 2018c; NC Electric Cooperatives, 2018). As described in Section 9.2, other states have likewise implemented a variety of policies to further encourage the deployment of storage in particular instances or to advance the pace at which deployment occurs. The following recommendations are provided for consideration if stakeholders and decision-makers are interested in interventions that might help to either increase the value or decrease the cost of energy storage, thus increasing the pace of deployment in the near-term.

- **Develop Competitive Procurement Process to Monetize Storage Services:** States operating under a variety of regulatory and market structures have experimented with different approaches to better reflect the potential of storage to provide multiple services, ranging from establishing standardized approaches for governing how storage can participate in various service markets (see, e.g., California [CPUC Decision 18-01-003]), the establishment of guidelines for the submission of energy storage proposals in the restructured state of Oregon (H.B. 2193, 2015), the adoption of specific tools or approaches for evaluating the value of storage in Washington (Docket UE-151069, 2017) and Oregon (UM 1751, 2016), and the identification or authorization of services to be considered in procurement decisions (including non-wires alternatives) in the vertically-integrated state of Colorado (HB 18-1270, 2018) and the restructured state of Massachusetts (HB 4857, 2018). The existence of storage provisions in the aforementioned CPRE program does provide one mechanism for the procurement of energy storage in North Carolina. The extent to which storage is competitive under such a process is partly function of the framework being used to evaluate applications (e.g., NCUC, 2018) as well as the terms under which selected applications must operate. It is therefore likely that the storage provisions of the

CPRE program will remain a source of continuing deliberations. For example, a June 25, 2018 NCUC Order calls for continued reporting on the outcomes of the CPRE Tranche 1 solicitation and an expectation of continued “discussions in good faith” among parties on the particular issue of energy storage provisions (Docket Nos. E-2, SUB 1159; E-7, SUB 1156; p8).

- **Develop a Standard Offer Program to Monetize Storage Services Provided by Smaller Projects:** While smaller energy storage projects may provide many of the same values not currently monetized in the current regulatory framework (see above), it may not be feasible for these projects to participate in a competitive procurement process, especially at residential scale. Instead, the value provided by these projects may be aggregated and compensated through a standard offer tariff. This tariff could offer compensation for various services provided by energy storage systems, with values updated as needed, perhaps as part of avoided cost proceedings. This could be initiated as a limited participation pilot program to evaluate participation and how values change over time, while providing some degree of certainty to participants. The incorporation of storage into Vermont’s existing standard offer program for renewable energy capacity was suggested by stakeholders in the context of that state’s recent storage study, as were concerns that use of a standard offer program vehicle might not lead to optimal deployment or operation decisions (VDPS, 2017).
- **Develop New Tariff Structures:** Though they may need to vary significantly based on customer class, appropriately designed rates and tariffs may provide additional value for energy storage (e.g., NCSEA, 2016; ESA, 2017; Stanfield et al., 2017). In North Carolina, a 2017 avoided cost ruling indicated a desire on the part of the NCUC to see rate structures that communicated clearer signals to encourage the deployment of advanced solar and energy storage (Docket No. E-100, SUB 148). Other states have experimented with storage-specific rate designs and tariff structures to this effect. Some examples include reverse demand response and storage-specific initiatives for commercial and industrial customers in the vertically-integrated state of Arizona (e.g., Docket no. E-01345A-17-0134), the development of time-varying rate pilot programs in the restructured state of Maryland (Public Conference No. 44, 2018), time-variable rates in the vertically-integrated state of Nevada (AB 405, 2017), and exclusion of wholesale storage from transmission service rates in Texas (PUCT Substantive Rule 25.192).
- **Create an Expedited or Streamlined Interconnection Process for Behind-the-Meter Systems:** Another option receiving consideration in other states is the development of an expedited or streamlined process for behind-the-meter or non-exporting systems. For example, revised or streamlined interconnection requirements are under consideration or have been adopted in Vermont (Rule 5.500) and the restructured state of New York (NYPSC CASE 15-E-0557, 2016).
- **Promote Data Access and Transparency:** In addition to the planning provisions described in 9.4.1 above, energy storage can be facilitated by providing hosting capacity analysis for third party developers (see, e.g., DER integration planning in the restructured state of Connecticut [2015 Connecticut General Statutes §16-244w]). On the consumer side, utilities could also provide customers detailed data on their own usage, thus putting them in a better position to evaluate if and how energy storage could be beneficial. Relevant examples include ongoing discussions surrounding Smart Grid Technology Plans in North Carolina, aggregated data access provisions in the vertically-integrated state of Hawaii (SB 2939, 2018), and grid data sharing proposals in California (SB 801, 2018).

- **Develop Targeted or Expanded REPS Cost-Recovery Funding Stream:** Utilities in the state are already making use of existing authorities under the REPS to recover costs pertaining to storage research and development (Duke Energy Carolinas, 2018b; Duke Energy Progress, 2018c). Continuing to utilize this funding mechanism, or as recommended by others (e.g., AJP, 2016), expanding and specifically targeting a provision to storage, may help to lower installation and operations costs while enhancing efforts to quantify and value storage services, thus facilitating deployment.
- **Establish a Procurement Goal:** Unlike a procurement requirement (discussed below), a procurement goal simply sets an aspirational target for energy storage capacity or the process by which a future requirement might be set. As a formally declared state policy objective, a procurement goal would also likely factor into other programmatic and/or regulatory decisions, thus further encouraging the deployment of storage indirectly. Specifically identified in our analysis were targets established, proposed, or evaluated in the restructured states of Massachusetts, New York, and New Jersey.

### 9.4.3 Accelerate

The following policy recommendations are provided for consideration if stakeholders and decision-makers wish to substantially increase the pace of energy storage deployment in the state. As reviewed in Section 9.2, experience in other states demonstrates the potential influence of targeted policy reforms on the deployment of energy storage. As many of the policy examples in this section are drawn from states with markedly different regulatory structures, market structures, and resource mixes, careful consideration should be given as to their applicability to a North Carolina system.

- **Develop Storage-Specific Incentives:** Multiple states have made use of tax and other incentives to encourage the deployment of energy storage (see, e.g., Endemann et al., 2018). Use of a state tax credit or other direct incentive to encourage energy storage would likewise recall similar measures once in place for solar in North Carolina (e.g., Hoyle, 2016). Identified in our review were programs in California (the Self-Generation Incentive Program [SGIP]) and Massachusetts (the Advancing Commonwealth Energy Storage [ACES] program). In the particular case of the SGIP, the program has undergone multiple rounds of revision as the program and market have evolved. Also identified were proposed tax exemptions and PACE programs in the vertically-integrated state of South Carolina (SB 261, 2017), a proposed rebate program in Hawaii (HB 1593, 2017), proposed tax credits in Virginia (HB 1018, 2018), and grants and loans for microgrid applications in Connecticut (Connecticut Public Act No. 16-196, 2012).
- **Incorporate Storage within the North Carolina REPS:** The existing North Carolina REPS provides a general framework within which to add, incorporate, or carve out a stand-alone energy storage target. Doing so, however, would require consideration of the eligible technologies, the manner in which a storage component of a REPS-like target is tracked, and how any RECS generated by storage-connected generation are to be treated (e.g., Holt and Olinsky-Paul, 2014). Short of development of a storage-specific carve-out in an REPS, it may be helpful to clarify the role of storage in existing REPS provisions, such as whether energy storage meets the definition of demand side management for the purposes of municipal utility and electric cooperative compliance obligations.
- **Develop a Clean Peak Standard:** Separate and apart from the REPS, it is possible to promote energy storage through what is known as a clean peak standard, a program that requires that

some portion of peak demand be met with renewable sources. By helping to shift the timing of renewable contributions to the grid, energy storage can play an important role in clean peak standards, though further technical analysis would be needed to assess the benefit of such an approach in North Carolina relative to the existing REPS. Clean peak programs, or programs to more generally consider the role of energy storage in addressing peak demand, have been proposed or adopted in, for example, Arizona, Massachusetts, and California.

- **Establish a Procurement Requirement:** A procurement requirement ensures that a set capacity of energy storage is deployed over a set interval. Procurement requirements established in California and Oregon were among the most often discussed in the sources reviewed here (see, e.g., NGA, 2016; Stanfield et al., 2017; VDPS, 2017; Endemann et al., 2018), but have also been proposed elsewhere (e.g., Minnesota [HF 3115 and SF 2711, 2018] and Nevada [SB 145, 2017]). While mandates such as procurement targets may provide certainty for utilities and developers, they may also lead to less-efficient outcomes than if the market were to develop independently (e.g., Bhatnagar and Loose, 2012).

## References

American Jobs Project (AJP) (2016). North Carolina Jobs Project: A Guide to Creating Advanced Energy Jobs. <http://americanjobsproject.us/wp-content/uploads/2016/04/NC-Full-report-update-4.13.pdf> (last accessed September 24, 2018).

Bhatnagar D, Currier A, Hernandez J, Ma O, Kirby B (2013). Market and Policy Barriers to Energy Storage Deployment: A Study for the Energy Storage Systems Program. SAND2013-7606. U.S. Department of Energy, Sandia National Laboratories, Albuquerque, NM.

Bhatnagar D, Loose V (2012). Evaluating Utility Procured Electric Energy Storage Resources: A Perspective for State Electric Utility Regulators. SAND2012-9422. U.S. Department of Energy, Sandia National Laboratories, Albuquerque, NM.

California Independent System Operator (ISO), California Public Utilities Commission, and California Energy Commission. (2014). Advancing and Maximizing the Value of Energy Storage Technology: A California Roadmap. [https://www.caiso.com/documents/advancing-maximizingvalueofenergystoragetechnology\\_californiaroadmap.pdf](https://www.caiso.com/documents/advancing-maximizingvalueofenergystoragetechnology_californiaroadmap.pdf) (last accessed October 10, 2018).

Center for the New Energy Economy (CNEE). (2017). State Brief: North Carolina. Colorado State University, Fort Collins, CO.

Dominion Energy (2017a). Kitty Hawk NC Microgrid Research Project, 2017 Study Report to North Carolina Utilities Commission, Company Exhibit GEH-1, North Carolina Utilities Commission, Raleigh, NC.

Dominion Energy (2017b). Virginia Electric and Power Company's Report of Its Integrated Resource Plan Before the Virginia State Corporation Commission and North Carolina Utilities Commission. Public Version. Case No. PUR-2017-00051; Docket No. E-100, Sub 147, Division of Public Utility Regulation, Richmond, VA, and North Carolina Utilities Commission, Raleigh, NC.

Duke Energy Carolinas. (2018a). Duke Energy Carolinas, LLC 2018 Integrated Resource Plan and 2018 REPS Compliance Plan Docket No. E-100, Sub 157, North Carolina Utilities Commission, Raleigh, NC.

Duke Energy Carolinas. (2018b). Duke Energy Carolinas, LLC's REPS Cost Recovery Rider and 2017 Compliance Report, Docket No. E-7, Sub 1162, North Carolina Utilities Commission, Raleigh, NC.

Duke Energy Carolinas (DEC), Duke Energy Progress (DEP). (2018). Duke Energy Carolinas, LLC's and Duke Energy Progress, LLC's Final pro forma CPRE Tranche 1 PPA, Docket Nos. E-2, Sub 1159 and E-7, Sub 1156, North Carolina Utilities Commission, Raleigh, NC.

Duke Energy Progress. (2018a). Duke Energy Progress, LLC Application for Certificate of Public Convenience and Necessity - Hot Springs Microgrid Solar and Battery Storage Facility, Docket No. E-2, Sub 1185, North Carolina Utilities Commission, Raleigh, NC.

Duke Energy Progress. (2018b). Duke Energy Progress, LLC 2018 Integrated Resource Plan and 2018 REPS Compliance Plan Docket No. E-100, Sub 157, North Carolina Utilities Commission, Raleigh, NC.

Duke Energy Progress. (2018c). Duke Energy Progress, LLC's REPS Cost Recovery Rider and 2017 Compliance Report, Docket No. E-2, Sub 1175, North Carolina Utilities Commission, Raleigh, NC.

Duke Energy Progress. (2018d). Duke Energy Progress, LLC Western Carolinas Modernization Project Annual Progress Report, Docket No. E-2, Sub 1089, North Carolina Utilities Commission, Raleigh, NC.

Endemann BB (ed.), Berry KA, Crouse EC, ...& Nahum NR (2018). K&L Gates Energy Storage Handbook. Version 2. <http://www.klgates.com/energy-storage-handbook-10-17-2017/> (last accessed August 31, 2018).

Energy Storage Association. (2017). State Policies to Fully Charge Advanced Energy Storage: The Menu of Options. Washington, D.C.

Energy Transition Lab. (2017). Modernizing Minnesota's Grid: An Economic Analysis of Energy Storage Opportunities. Institute on the Environment, University of Minnesota. Online at: <http://energytransition.umn.edu/wp-content/uploads/2017/07/Workshop-Report-Final.pdf> (last accessed October 17, 2018).

Hart DM, Bonvillian WB, Austin N (2018). Energy Storage for the Grid: Policy Options for Sustaining Innovation. MIT Energy Initiative Working Paper. Cambridge, MA.

Hledik R, Chang J, Lueken R, Pfeifenberger J, Pedtke JI, Vollen J (2018). The Economic Potential for Energy Storage in Nevada. Report prepared for the Public Utilities Commission of Nevada, Nevada Governor's Office of Energy. The Brattle Group. Cambridge, MA.

Holt E, Olinsky-Paul T (2014). Does Energy Storage Fit in an RPS? Report Prepared for the State-Federal RPS Collaborative. Clean Energy States Alliance. Montpelier, VT.

Hoyle J (2016). Expiration of the Renewable Energy Tax Credit in NC: The end of an era or an impetus for innovation? <https://energy.appstate.edu/news/2793> (last accessed November 15, 2018).



Maryland Department of Natural Resources. (2017a). Energy Storage Report Update. <https://dnr.maryland.gov/pprp/Documents/Status-Report-PPRAC-20171115.pdf> (last accessed October 10, 2018).

Maryland Department of Natural Resources (MDNR). (2017b). Energy Storage Study Status Update as of October 26, 2017. <http://dnr.maryland.gov/pprp/Documents/1b-Report-Status-Update-Memo.pdf> (last accessed September 14, 2018).

Massachusetts Department of Energy Resources (MDER), Massachusetts Clean Energy Center, Customized Energy Solutions, Sustainable Energy Advantage, Daymark, Alevo Analytics (2016). State of Charge: Massachusetts Energy Storage Initiative. [http://energystorage.org/system/files/attachments/ma\\_storage\\_study.final\\_w5768299x7ac2e.pdf](http://energystorage.org/system/files/attachments/ma_storage_study.final_w5768299x7ac2e.pdf) (last accessed September 14, 2018).

Missouri Public Service Commission (MPSC). (2018). Staff Report on Distributed Energy Resources. Online at: <https://www.efis.psc.mo.gov/mpsc/commoncomponents/viewdocument.asp?DocId=936094616> (last accessed October 12, 2018).

National Governors Association (NGA) (2016). State Strategies for Advancing the Use of Energy Storage. Washington, D.C.

NC Electric Cooperatives. (2018). Microgrids. <https://www.ncelectriccooperatives.com/energy-innovation/microgrids/> (last accessed November 23, 2018).

New York Battery and Energy Storage Technology Consortium (NY-BEST). (2016). Energy Storage Roadmap. Online at: <https://www.ny-best.org/page/2016-energy-storage-roadmap-new-yorks-electric-grid> (last accessed October 17, 2018).

North Carolina Clean Energy Technology Center (NCCETC) (2018). The 50 States of Grid Modernization: Q1 2018 Quarterly Report, Raleigh, NC.

Ledford P (2015). Batteries Not Included: Identifying and Approaching Barriers to Batteries on the Grid. North Carolina Sustainable Energy Association. Raleigh, NC.

North Carolina Sustainable Energy Association (NCSEA) (2016). Energy Storage Working Group Interim Report. Online at: [https://energync.org/wp-content/uploads/2017/03/Energy Storage Working Group Interim Report.pdf](https://energync.org/wp-content/uploads/2017/03/Energy_Storage_Working_Group_Interim_Report.pdf) (last accessed September 18, 2018).

North Carolina Utilities Commission (NCUC) (2018). Comments of the Public Staff in Response to Joint Motion of NCSEA and NCCEBA In the Matter of: Request of Duke Energy Carolinas, LLC and Duke Energy Progress, LLC, Petition for Approval of CPRE Program to Implement NC Gen Stat 62-110.8. Docket No. E-2, SUB 1159; Docket No. E-7, SUB 1156, Raleigh, NC.

Working Group Interim Report. [https://energync.org/wp-content/uploads/2017/03/Energy Storage Working Group Interim Report.pdf](https://energync.org/wp-content/uploads/2017/03/Energy_Storage_Working_Group_Interim_Report.pdf) (last accessed September 18, 2018).

Stanfield S, Petta JS, Auck SB (2017). *Charging Ahead: An Energy Storage Guide for State Policymakers*. Interstate Renewable Energy Council, Latham, New York.

U.S. Department of Energy. (2013). *Grid Energy Storage*. Washington, D.C.

Vermont Department of Public Service (VDPS). (2017). *Final Report on Deploying Storage on the Vermont Electric Transmission and Distribution System*. Montpelier, VT.

Winfield M, Shokrzadeh S, Jones A (2018). Energy policy regime change and advanced energy storage: A comparative analysis. *Energy Policy*, 115: 572–583.

## Further Reading

Colorado State University Center for the New Energy Economy. (2017). Nevada State Brief. Online at: [http://cnee.colostate.edu/wp-content/uploads/2017/07/State-Brief\\_NV\\_Sept\\_update.pdf](http://cnee.colostate.edu/wp-content/uploads/2017/07/State-Brief_NV_Sept_update.pdf) (last accessed August 1, 2018).

Connecticut Department of Energy and Environmental Protection. (2018). *Comprehensive Energy Strategy*. Online at: [http://www.ct.gov/deep/lib/deep/energy/ces/2018\\_comprehensive\\_energy\\_strategy.pdf](http://www.ct.gov/deep/lib/deep/energy/ces/2018_comprehensive_energy_strategy.pdf) (last accessed August 1, 2018).

Governor's Office of Energy. (2017). Nevada 2017 Status of Energy Report. Online at: [http://energy.nv.gov/uploadedFiles/energynv.gov/content/About/2017%20SOE%20v10.4%20\(High%20Res\).pdf](http://energy.nv.gov/uploadedFiles/energynv.gov/content/About/2017%20SOE%20v10.4%20(High%20Res).pdf) (last accessed October 12, 2018).

Maryland Department of Natural Resources. (2018). *Energy Storage Technology Study Initial Findings*. Online at: <https://dnr.maryland.gov/pprp/Documents/Initial-Findings-Final.pdf> (last accessed August 1, 2018).

Michigan Public Service Commission. (2018). *Report on the MPSC Staff Study to Develop a Cost-of-Service-based Distributed Generation Program Tariff*. Online at: [https://www.michigan.gov/documents/mpsc/MPSC\\_Staff\\_DG\\_Report\\_with\\_Appendices\\_61477\\_2\\_7.pdf](https://www.michigan.gov/documents/mpsc/MPSC_Staff_DG_Report_with_Appendices_61477_2_7.pdf) (last accessed August 1, 2018).

New York Battery and Energy Storage Technology Consortium (NY-BEST). (2018). *Energy Storage Guide*. Online at: <https://www.ny-best.org/sites/default/files/resources/Energy%20Storage%20Guide%205.17.pdf> (last accessed October 15, 2018).

New York Independent System Operator (NYISO). (2017). *The State of Storage: Energy Storage Resources in New York's Wholesale Electricity Markets*. Online at: [https://home.nyiso.com/wp-content/uploads/2017/12/State\\_of\\_Storage\\_Report\\_Final\\_1Dec2017.pdf](https://home.nyiso.com/wp-content/uploads/2017/12/State_of_Storage_Report_Final_1Dec2017.pdf) (last accessed October 12, 2018).

The Climate Group (2017). *California's Energy Storage Procurement Mandate*. Online at: [https://www.theclimategroup.org/sites/default/files/downloads/etp\\_californiacasestudy\\_apr2017.pdf](https://www.theclimategroup.org/sites/default/files/downloads/etp_californiacasestudy_apr2017.pdf) (last accessed October 15, 2018).

## 10. Future Work

### 10.1 Modeling of Electric Vehicle Deployment

Electric vehicles (EVs) will eventually add a substantial amount of new load to the electricity grid in North Carolina and beyond. EVs can affect both the growth rate of electricity demand, temporal distribution of demand across days and seasons, and could also be used to assist in grid operations. EV penetration has the potential to affect the cost-effectiveness of grid storage under future scenarios, however, a detailed analysis of EV deployment was beyond the scope of this study.

We could perform capacity expansion with our open source energy system model Tools for Energy Model Optimization and Analysis (Temoa), which was used to perform the bulk energy time shifting and peak capacity deferral analysis in this study. The proposed analysis would explore how an increase penetration of EVs could affect electricity demand, whether EVs could provide services to the electricity grid, and how they may affect the value streams addressed in this report. Our analysis would also consider various smart car charging types including home charging, regular station charging, and DC fast station charging as well as charging strategies that are aligned with supporting grid operations. The potential benefits to the grid include reliability enhancement, peak shaving, and integration of other types of distributed energy resources like photovoltaic generation.

### 10.2 Consideration of Demand Response

By effectively shifting the timing of electricity production, grid-connected energy storage can help ensure reliable service, decrease costs to rate payers, reduce the environmental impacts of electricity production, and integrate variable renewables such as wind and solar power. Many of the storage services examined in this report could also be provided with demand management strategies, whereby consumers alter consumption in response to some signal or cede partial control of energy consuming appliances to utilities. For example, time-of-use pricing regimes and/or critical event pricing systems may be employed to reduce peak consumption, thereby reducing the need for peaking plants and certain transmission and distribution expansions or their energy storage alternatives. There is empirical evidence that such price-based programs can elicit timely demand reductions and that those load responses are increased with greater lead time for electricity rate changes and when households are provided more information about their home energy use in general.

As an alternative to sending price signals to consumers to incentive demand responses, many utilities, including those with service territories in North Carolina, offer consumers compensation in exchange for direct control of major energy using appliances. The utilities can then shut these appliances off during periods of high demand. For example, Duke Energy offers the “Power Manager” program where, in exchange for giving participating customers an annual bill credit, customers allow Duke Energy to install a “smart device” that will reduce the energy use of the customer’s air conditioning unit when Duke Energy sends the device a signal to do so.

There are possibilities for these types of interventions to be applied and/or expanded in North Carolina. For example, the Duke Energy service territories in North Carolina have winter and summer peak loads per customer ratios that exceeded the 75<sup>th</sup> percentile among all investor-owned utility service territories, though they have relatively high energy savings per residential customer

ratios from their energy efficiency programs.<sup>9</sup> Regardless of the potential for demand-related interventions to provide meaningful and timely demand responses, determining how the cost effectiveness of such interventions compares to alternative supply-side options in North Carolina would be difficult to ascertain at this junction. While there has been empirical work to estimate price elasticities of demand and responses to more directed price intervention policies, the results of these studies are very locationally dependent. To our knowledge, such price intervention experiments have not been analyzed in North Carolina. Similarly, while Duke Energy currently does do direct load control programs, to our knowledge there has been no empirical analyses undertaken to determine how changing compensation rates alter participation rates. Without this knowledge, it is difficult to make cost comparisons across various levels of direct load control participation rates and cost comparisons to supply-side alternatives.

---

<sup>9</sup> This assertion is based on data available from EIA's 861 data in 2017. To calculate the peak-to-customer ratios, we divided the quoted summer and winter peak loads separately by utility by the sum of customers across residential, commercial, and industrial classes. Likewise for the energy savings per residential customers, we take quoted residential energy savings values for the given utility from their energy efficiency programs divided by the number of quoted residential customers.

## Appendices

<b>Appendix A</b>	Information on stakeholder engagement	p. 173
<b>Appendix B</b>	Supplementary operational results from the bulk energy time shifting and peak capacity deferral analysis (Section 6.5)	p. 188
<b>Appendix C</b>	Description of Temoa input database used for the bulk energy time shifting and peak capacity deferral analysis (Section 6.5)	p. 206
<b>Appendix D</b>	Stakeholder comments received on specific elements from Section 9: Identification of Barriers and Policy Options	p. 232
<b>Appendix E</b>	Description of Policy Categories and individual Policy Types used to classify policies in the review of existing state initiatives on energy storage (Section 9)	p. 235
<b>Appendix F</b>	Compilation of state policies related to energy storage (Section 9)	p. 238

## Appendix A: Information on the Stakeholder Input Process

### 1.1. Identification of Stakeholders

As discussed in the original NC State Storage Proposal to the NC Policy Collaboratory, our team felt it was critical to conduct stakeholder engagement activities to help guide and inform our analysis. Along with stakeholders interested in the storage study provision that were directly involved in the development and passage of HB 589, we publicized the study working group widely across the energy community in North Carolina as well as to national utility and storage trade groups to publicize to their memberships. No potential stakeholder that requested to participate was excluded, although many chose to receive email updates or to monitor the website without participating directly in stakeholder meetings or providing written comments. Including the research team and graduate students that worked on the project, the full stakeholder list we identified currently numbers over 210 individuals, organizations and firms from various sources including:

- Academics;
- Advocacy & Environmental Groups;
- National and State Level Energy Trade Groups;
- Government Agencies and Regulators;
- Investor-Owned Utilities, Municipals and EMCs;
- Large Energy End Users;
- Financial and Legal Firms and Organizations;
- Both Policy/Market Consulting Firms and Technical Consulting and Services Firms;
- Storage Equipment Manufacturers and Supply Chain Companies; and
- Private Energy Project Developers.

### 1.2. Full Stakeholder Meetings

As noted in our introduction, our approach to this study has been informed by two key factors: (1) the storage market is rapidly changing, and (2) transparency in analysis helps to engender trust among stakeholders. To help ensure our research was using the most up-to-date data and market assertions while at the same time maximizing the transparency of our assumptions, inputs and approaches to modeling process for all stakeholders, we placed significant emphasis on three public stakeholder meetings (copies of the agendas and registered attendees included in this Appendix) to help guide and inform our analysis. The stakeholder workshops allowed the team to elicit feedback on challenges and opportunities relating to storage market deployment and to keep stakeholders apprised of our progress and solicit feedback. More detailed information regarding each of the workshops, including all presentations, the initial energy services proposed list used for discussion in Meeting #1, pre-workshop survey results used in Meeting #2, and summary information from in-meeting discussions where applicable are all available for download on the study website at <https://energy.ncsu.edu/storage/stakeholder-meetings/>.

The initial full stakeholder meeting, held in **February 2018**, served several purposes. First, we presented an overview of the legislative charge for the study and the scope of our team’s research proposal, along with a summary of the current status of storage policy in the U.S. to give the group a common starting point for discussions. We then broke into groups based upon the types of constituents represented in the room to better understand the perceived value and barriers associated with storage. Two significant questions were discussed at length. First, we asked the groups to evaluate the potential for storage to fulfill a list of enumerated services culled from a literature review of possible services. We provided a list of these services, along with a brief definition of each. Stakeholders worked in groups to identify services or applications that were missing from our list, and to assess the importance of different services from their perspective. Second, we asked them to identify any economic, policy, regulatory, and/or technological barriers preventing storage adoption in NC. This initial input helped our team to define the focus for the scope of the study based upon the most prominent concerns of the stakeholder groups.

The second stakeholder meeting was held in **June 2018**. Our goals for this meeting centered around presenting our initial modeling approaches to seek input on their appropriateness and completeness in the eyes of stakeholders. This included an initial presentation of cross-cutting, foundational elements in the study – a working definition of the scope of storage for the study, some common baseline cases to be examined in modeling scenarios, and initial technology cost data. Additionally, we introduced our team leads for modeling activities in the the key storage service categories: Generation, Resource Adequacy, Transmission Services, Distribution Services, and End-User Services. The team leads presented the initial approaches to their modeling approaches in their respective areas and then received feedback from the stakeholder groups. Finally, we presented an initial review of our baseline understanding of existing North Carolina policies that relate to energy storage. This allowed stakeholders to comment on the scope of our policy framework - whether too broad or too narrow in their eyes. Again, this input helped us to refine the scope and approach of the study and to begin to build stakeholder trust of the transparency of the study methods and expected results.

We held a final full stakeholder meeting in early **October 2018**. This meeting allowed the team to make presentations to the stakeholders of their initial modeling results for the various service categories being studied. The team also gave a more extensive presentation of North Carolina policies and took input from stakeholders on potential barriers to storage deployment. This was an opportunity for stakeholders to identify any final perceived gaps analysis before the team moved to the final stages of the study, including value stacking opportunities across service options and overall synthesis of the individual modeling exercises into larger study conclusions.

### **1.3. Additional Individual Stakeholder Meetings**

Because of the varying levels of interest in the technical analysis, we additionally held more than a dozen one-on-one meetings at the request of individual stakeholder organizations and firms to more deeply discuss study details. Members of the team met with a wide range of stakeholder groups

throughout the process. No meetings requested were refused. These meetings usually focused on either stakeholder interest in the inclusion of specific storage technologies or specific modeling issues that could be discussed in more detail than in the larger stakeholder meetings. Several meetings also touched on expectations for the policy recommendations section of the report, either suggesting a wider or narrower approach depending on the stakeholder perspective. Groups that we met with included:

- Carolina Utility Customers Association (CUCA)
- Cypress Creek Renewables
- Duke Energy
- ElectriCities
- Energy Storage Association (ESA)
- Enovation Partners
- Environmental Defense Fund
- Fluence – a Siemens and AES Company
- InnovoGraph / Sustain NC
- NC Sustainable Energy Association (NCSEA)
- NCSEA Membership - Storage Working Group
- NC Electric Membership Cooperatives Association
- NCUC Public Staff
- NC Utilities Commission (NCUC)
- NC WARN
- Nelson Mullins Riley & Scarborough LLP
- Strata Solar

#### **1.4. IRB Status of Stakeholder Survey Request (Meeting #2)**

As preparation for the second full stakeholder meeting, we issued a formal survey to stakeholders to get insights on their opinions of different possible storage applications to help guide the session discussions. Because the survey in which we engaged involved research data collection from “human subjects” (or stakeholders as we referred to them), we sought guidance from the NCSU Institutional Review Board for the Protection of Human Subjects in Research (IRB) to determine if any protective protocols were needed as a part of our stakeholder interaction and input collection.

The mission of the IRB is to facilitate compliant research with human subjects. This is accomplished through three primary goals:

- First, to protect the rights and welfare of human research subjects through project review.
- Second, to foster compliance with institutional policy and federal regulations by facilitating institutional personnel’s efforts in utilizing living human subjects for research and other scholarly pursuits that are systematic and designed to contribute to generalizable knowledge.



- Third, to provide education to institutional personnel on the ethical use of human subjects. Helping scientists and instructors to be stellar stewards of the trust of our human subjects is of paramount concern.

Any research with human subjects at NC State must go through the NC State IRB. Unauthorized use of external IRBs is not permitted.

Our research team submitted an application that included the proposed survey for IRB review and following the meeting we asked for guidance from the IRB regarding making the anonymous data available on the study website. The research survey received administrative review and was approved as exempt from the further IRB review according to policy as outlined in the Code of Federal Regulations (Exemption: 46.101. Exempt b.2).

# AGENDA

## Energy Storage Study Stakeholder Input Meeting

February 15, 2018 – 12:30 pm

Jane S. McKimmon Center on the Campus of NC State University  
1101 Gorman St, Raleigh, NC 27606

- 12:30 PM Welcome – Joe DeCarolis, Professor, Study Team Lead and Steve Kalland, NC Clean Energy Technology Center
- 12:35 PM Overview of the Status of Storage Policy in the U.S. – Autumn Proudlove, NC Clean Energy Technology Center
- 12:50 PM Overview of the Legislative Charge and the NCSU Research Proposal – Joe DeCarolis
- 1:35 PM Logistics for Discussions – Stakeholder “Groups”
- We will break into groups based upon the types of constituents represented in the room to better understand the perceived value and barriers associated with storage.*
- 1:40 PM Introduction to Stakeholder Discussion 1: From your perspective, evaluate the potential for storage to fulfill each of the enumerated services.**
- There are several applications and services that storage can fulfill. We will provide a list of these services, along with a brief definition of each. Stakeholders will work in groups to identify any services or applications that are missing from our list, and assess the importance of different services their perspective.*
- 1:50 PM Stakeholder Group Discussion on Question 1
- 2:10 PM Group Report Out on Question 1
- 2:30 PM BREAK
- 2:40 PM Introduction to Stakeholder Discussion 2: Identify the economic, policy, regulatory, and/or technological barriers preventing storage adoption in NC.**
- Given that a suite of storage technologies can be used to meet different grid-related services, stakeholders will work in groups to identify barriers to adoption.*
- 2:50 PM Stakeholder Discussion on Question 2
- 3:10 PM Group Report Out on Question 2
- 3:30 PM Conclusions and Schedule Going Forward

## Registration and Attendee List

### Energy Storage Study Stakeholder Input Meeting

February 15, 2018 – 12:30 pm

Jane S. McKimmon Center on the Campus of NC State University

1101 Gorman St, Raleigh, NC 27606

First Name	Last Name	Company
Rob	Aldina	North Carolina Sustainable Energy Assoc
Zach	Ambrose	Ambrose Strategy
Hayden	Bauguess	ElectriCities of NC
Daniel	Brookshire	NC Sustainable Energy Association
Max	Burden	University Sustainability Office
Brooks	Camp	Advanced Energy
Chris	Carmody	NC Clean Energy Business Alliance
Will	Clayton	Stratasolar
Tommy	Cleveland	Advanced Energy
Marshall	Conrad	NC General Assembly
Sarah	Cosby	Dominion Energy
Brett	Crable	Dominion Energy
Thad	Cully	Vote Solar
Cyrus	Dastur	Advanced Energy
Joe	DeCarolis	NC State University
Ron	DiFelice	Energy Intelligence Partners
Tim	Dodge	Public Staff - NCUC
Chris	Doerfler	3DFS
Kim	Duffley	North Carolina Utilities Commission
Ken	Dulaney	FREEDM Systems Center
Paul	Esformes	Ecoplexus, Inc.
Harrison	Fell	NCSU
Nate	Finucane	Powercosts
Jack	Floyd	NC Utilities Commission Public Staff
John	Franceski	Dominion
John	Gajda	Duke Energy
Christopher	Galik	North Carolina State University
Chris	Gambino	NCSU
Kelsy	Green	Advance Energy
Faeza	Hafiz	1987
Keith	Herbs	United Renewable Energy LLC
Bob	Hinton	North Carolina Utilities Commission Public Staff
Ray	Hohenstein	Fluence
Joe	Hollingsworth	NCSU
Preston	Howard	NCMA
Jeremiah	Johnson	NCSU
Stephen	Kalland	NC Clean Energy Technology Center
Carl	LaPlace	Triangle Microworks

Scott	Laster	Kairos Government Affairs
Evan	Lawrence	North Carolina Utilities Commission Public Staff
John	Lepper	IBM
Brian	Lips	NC Clean Energy Technology Center
Ning	Lu	North Carolina State University
David	Lubkeman	North Carolina State University
Jay	Lucus	North Carolina Utilities Commission
Brad	Luyster	S&C Electric/IPERC
Julie	Manzari	Dominion Energy
Sean	McCartney	Holocene Clean Energy
Catie	McEntee	NCSU
James	McLawhorn	Public Staff - Electric Division
Berry	McMurray	Advanced Energy
Sarah	McQuillan	Kairos Government Affairs
Sharon	Miller	Carolina Utility Customers Association
Stew	Miller	Yes Solar Solutions
Grant	Millin	InnoGraph / Sustain NC
Ben	Molthen	Holocene Clean Energy
Kate	Mueller	NCSU
David	Mulcahy	NCSU
Jim	Musilek	NC Electric Membership
Jay	Nemeth	Oakhurst Energy Solutions
James	O'Connor	3e Enterprises Group
Maureen	O'Conner	Fayetteville Public Works Commission
Kevin	O'Donnell	Nova Energy Consultants, Inc.
Brian	O'Hara	Stratasolar
Anatoli	Oleynik	3DFS
Neha	Patankar	North Carolina State University
Hannah	Pifer	ElectriCities of NC
Autumn	Proudlove	NC Clean Energy Technology Center
Daniel	Real	Southern Research
Sally	Robertson	NC WARN
Anderson	Rodrigo de Queiroz	NCCU
Matthew	Schultz	Duke Energy
Sun	Sun	North Carolina State University
Anne	Tazewell	Clean Tech
Jeff	Thomas	Public Staff - Electric Division
Jeff	Warren	NC Policy Collaboratory
Sam	Watson	North Carolina Utilities Commission
Michael	Youth	NC Electric Cooperatives

# AGENDA

## Energy Storage Study Stakeholder Input Meeting

June 27, 2018, 1:00 pm - 4:30 pm

Jane S. McKimmon Center on the Campus of NC State University  
1101 Gorman St, Raleigh, NC 27606

- 1:00 PM Welcome – Joe DeCarolis, Professor, Study Team Lead and Steve Kalland, NC Clean Energy Technology Center
- 1:10 PM Facilitation Process Overview – Expectations –
- 1:20 PM Presentation of Cross-Cutting Elements in the Study – Definition of Storage, Common Baseline Scenarios and Technology Cost Data + Related Survey Results– Joe DeCarolis**
- 1:35 PM Table Discussion of Presentation and Survey Results + Question Submission  
*Each table will submit questions through anonymous online platform for use in full stakeholder Q&A to follow*
- 1:45 PM Full Stakeholder Question and Answer
- 1:55 PM Presentation of Study Approaches to Energy Storage Services by Use Category**  
**End-User Services + Related Survey Results -- Isaac Panzarella**  
**Distribution Services + Related Survey Results -- David Lubkeman**
- 2:25 PM Table Discussion of Presentation and Survey Results + Question Submission
- 2:35 PM Full Stakeholder Question and Answer
- 2:45 PM BREAK
- 3:00 PM Presentation of Study Approaches to Energy Storage Services by Use Category (cont'd)**  
**Transmission Services + Related Survey Results -- David Mulcahy**  
**Generation/Resource Adequacy + Related Survey Results -- Anderson de Queiroz and Ning Lu**
- 3:30 PM Table Discussion of Presentation and Survey Results + Question Submission
- 3:40 PM Full Stakeholder Question and Answer
- 3:50 PM Baseline Review of NC Policies that Relate to Energy Storage + Related Survey Results -  
- Christopher Galik**
- 4:05 PM Table Discussion of Presentation and Survey Results + Question Submission
- 4:15 PM Question and Answer Period
- 4:25 PM Conclusions and Schedule Going Forward

## Registered Attendee List

### 2<sup>nd</sup> Energy Storage Study Stakeholder Input Meeting

June 27, 2018

Jane S. McKimmon Center on the Campus of NC State University  
1101 Gorman St, Raleigh, NC 27606

First Name	Last Name	Affiliation
Zach	Ambrose	Ambrose Strategy
Mike	Atkinson	Doosan Grid Tech
David	Barnes	ElectriCities of NC
Hayden	Bauguess	ElectriCities of NC
Daniel	Brookshire	NC Sustainable Energy Association (NCSEA)
Max	Burden	NC State University, University Sustainability Office
Chris	Carmody	NC Clean Energy Business Alliance (NCCEBA)
Sarah	Cosby	Dominion Energy
Thad	Culley	Vote Solar
Raj	Dalal	Eaton Corporation
Cyrus	Dastur	Advanced Energy
Joe	DeCarolis	NC State University, Civil, Construction, and Environmental Engineering
Dionne	Delli-Gatti	Environmental Defense Fund (EDF)
Chris	Doerfler	3DFS
Kim	Duffley	NC Utilities Commission
Paul	Esformes	Ecoplexus, Inc.
Jack	Floyd	NC Utilities Commission - Public Staff
JJ	Froehlich	Self-Help Credit Union
Christopher	Galik	NC State University, Public Administration
Chris	Gambino	NC State University, Public Administration
Bob	Hinton	NC Utilities Commission - Public Staff
Ray	Hohenstein	Fluence – a Siemens and AES Company
Brad	Ives	UNC-Chapel Hill, NC Policy Collaboratory
Ken	Jennings	Duke Energy
Robert	Josey	NC Utilities Commission - Public Staff
Steve	Kalland	NC State University, NC Clean Energy Technology Center
Sam	Kliwer	Cypress Creek Renewables
Kelli	Kukura	Duke Energy
Evan	Lawrence	NC Utilities Commission - Public Staff

John	Lepper	IBM
Ning	Lu	NC State University, Electrical and Computer Engineering
David	Lubkeman	NC State University, Electrical and Computer Engineering
Sean	McCartney	Holocene Clean Energy
Betsy	McCorkle	Kairos Government Affairs
James	McLawhorn	NC Utilities Commission - Public Staff
Berry	McMurray	Advanced Energy
Sarah	McQuillan	Kairos Government Affairs
Sharon	Miller	Carolina Utility Customers Association, Inc. (CUCA)
Stew	Miller	Yes Solar Solutions
Grant	Millin	InnoGraph / Sustain NC
David	Mulcahy	NC State University, Electrical and Computer Engineering
Jay	Nemeth	Oakhurst Energy Solutions
Kevin	O'Donnell	Nova Energy Consultants, Inc.
Brian	O'Hara	Stratasolar
James	O'Connor	3e Enterprises Group
Hisham	Othman	Quanta Technologies
Isaac	Panzarella	NC State University, NC Clean Energy Technology Center
Hannah	Pifer	ElectriCities of NC
Autumn	Proudlove	NC State University, NC Clean Energy Technology Center
Daniel	Real	
Anderson	Rodrigo de Queiroz	NC Central University, School of Business
Susan	Sanford	Research Triangle Cleantech Cluster (RTCC)
Matthew	Schultz	Duke Energy
Achyut	Shrestha	NC State University, NC Clean Energy Technology Center
Anne	Tazewell	NC State University, NC Clean Energy Technology Center
Jeff	Thomas	NC Utilities Commission - Public Staff
Steven	Tulevech	
Sarah	Vondracek	
Steve	Wall	UNC Institute for the Environment / NC Policy Collaboratory
Jeff	Warren	UNC-Chapel Hill, NC Policy Collaboratory
Jim	Warren	NC WARN
Sam	Watson	NC Utilities Commission
Michael	Youth	NC Electric Membership Cooperatives
Jim Halley	Halley	Ecoplexus
Diane	Cherry	NCSEA
Kevin	Martin	NC Energy Program

Tyler	Stoff	Environmental Defense
Danny	Sodano	NCSU
Chris	Cone	EnerNex
Ross	Dula	UNC Chapel Hill
Wenyuan	Tang	NCSU ECE
Isaac	Nicchitta	NC Office of the Governor
Vincent	Potter	NCSU



# AGENDA

## Energy Storage Study Stakeholder Input Meeting

October 2, 2018, 12:30 pm – 5:00 pm

Jane S. McKimmon Center on the Campus of NC State University  
1101 Gorman St, Raleigh, NC 27606

- 12:30 PM **Welcome, Overview of Study, Current Status, Scope of Today’s Discussion – Joe DeCarolis, Professor, Study Team Lead**
- 12:45 PM Table Discussion of Presentation + Question Submission  
*We will not group stakeholders by table. Stakeholders will write questions down pen and paper, and scribes will enter into a Google Doc. Speaker will address a 2-3 questions before we move on.*
- 12:55 PM Full Stakeholder Question and Answer

### **Presentation of Study Approaches to Energy Storage Services by Use Category**

- 1:00 PM End-User Services -- Isaac Panzarella**
- 1:15 PM Table Discussion of Presentation + Question Submission
- 1:25 PM Full Stakeholder Question and Answer
- 1:30 PM Distribution Services -- David Lubkeman**
- 1:45 PM Table Discussion of Presentation + Question Submission
- 1:55 PM Full Stakeholder Question and Answer
- 2:00 PM BREAK**
- 2:15 PM Transmission Services -- David Mulcahy**
- 2:30 PM Table Discussion of Presentation + Question Submission
- 2:40 PM Full Stakeholder Question and Answer
- 2:45 PM Bulk Energy / Peak Capacity Deferral -- Anderson de Queiroz**
- 3:00 PM Table Discussion of Presentation + Question Submission
- 3:10 PM Full Stakeholder Question and Answer
- 3:15 PM Frequency Regulation -- Ning Lu**
- 3:30 PM Table Discussion of Presentation + Question Submission
- 3:40 PM Full Stakeholder Question and Answer
- 3:45 PM Solar Clipping – Jeremiah Johnson**
- 4:00 PM** Table Discussion of Presentation + Question Submission
- 4:10 PM Full Stakeholder Question and Answer
- 4:15 PM Baseline Review of NC Policies that Relate to Energy Storage + Related Survey Results -  
- Christopher Galik**
- 4:30 PM Table Discussion of Presentation and Survey Results + Question Submission
- 4:40 PM Full Stakeholder Question and Answer
- 4:45 PM Conclusions and Schedule Going Forward

## Registered Attendee List

### 3<sup>rd</sup> Energy Storage Study Stakeholder Input Meeting

October 2, 2018 – 12:30 pm

Jane S. McKimmon Center on the Campus of NC State University

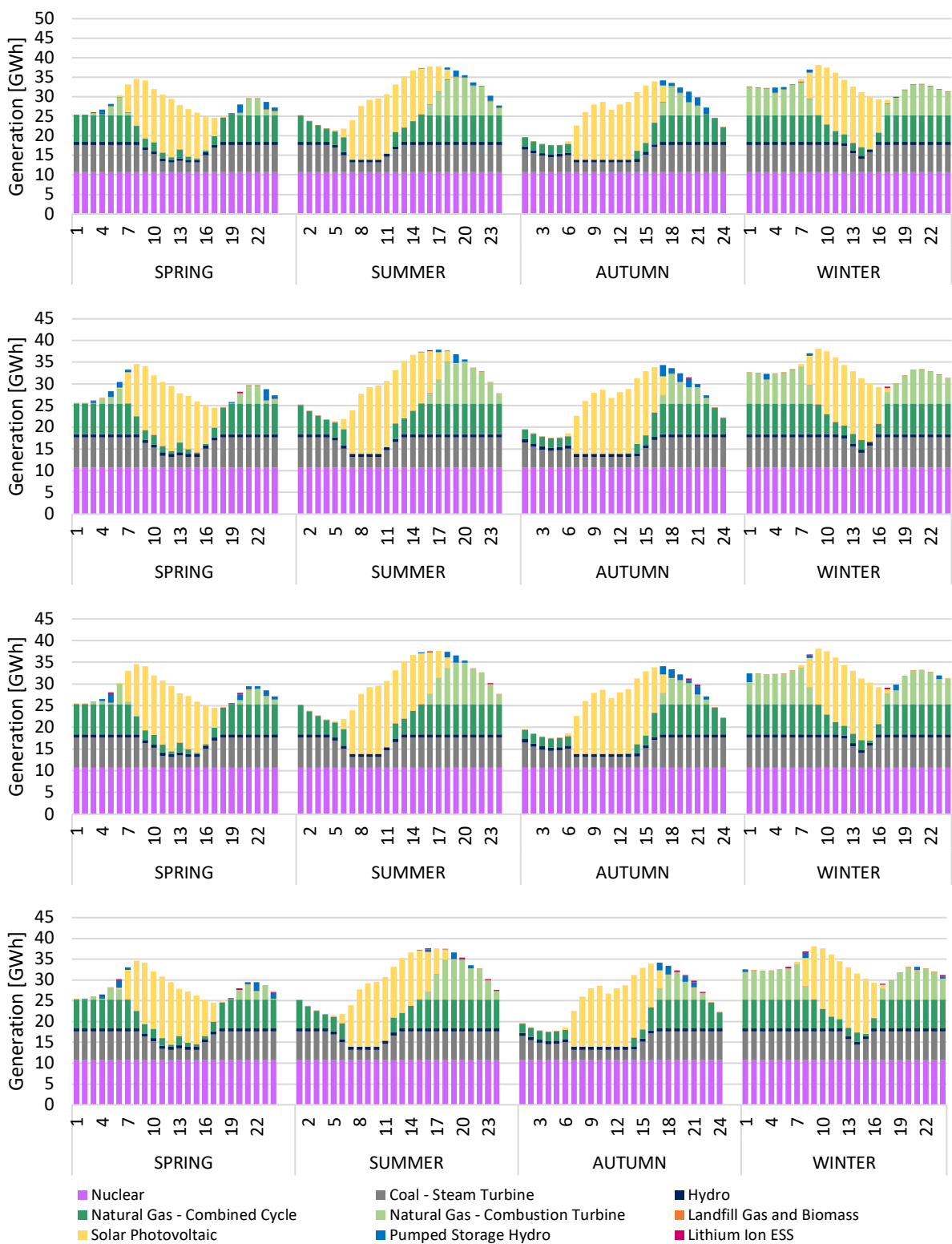
1101 Gorman St, Raleigh, NC 27606

First Name	Last Name	Affiliation
Asmaa	Alrushoud	NC State University, Electrical and Computer Engineering
Rubenka	Bandyopadhyay	Advanced Energy
Hayden	Bauguess	ElectriCities of NC
Andy	Bilich	Environmental Defense Fund (EDF)
Daniel	Brookshire	NC Sustainable Energy Association (NCSEA)
Chris	Carmody	NC Clean Energy Business Alliance (NCCEBA)
Diane	Cherry	NC Sustainable Energy Association (NCSEA)
Nathan	Clark	OPDE Group   Horus Renewables
Sarah	Cosby	Dominion Energy
Thad	Culley	Vote Solar
Raj	Dalal	Eaton Corporation
Nicholas	Dantonio	McGuireWoods LLP
Joe	DeCarolis	NC State University, Civil, Construction, and Environmental Engineering
Ron	DiFelice	Energy Intelligence Partners
Paul	Esformes	Ecoplexus, Inc.
Harrison	Fell	NC State University, Agricultural and Resource Economics
Nate	Finucane	Power Costs, Inc. (PCI)
Jack	Floyd	NC Utilities Commission - Public Staff
JJ	Froehlich	Self-Help Credit Union
Andrew	Fusco	ElectriCities of NC
Christopher	Galik	NC State University, Public Administration
Kelsy	Green	Advanced Energy
Faeza	Hafiz	NC State University, Electrical and Computer Engineering
Jim	Halley	Ecoplexus
Steve	Hantzmon	Hexagon Energy
Marlee	Hassell	UNC-Chapel Hill
Brad	Ives	UNC-Chapel Hill, NC Policy Collaboratory
Ken	Jennings	Duke Energy
Jeremiah	Johnson	NC State University, Civil, Construction, and Environmental Engineering

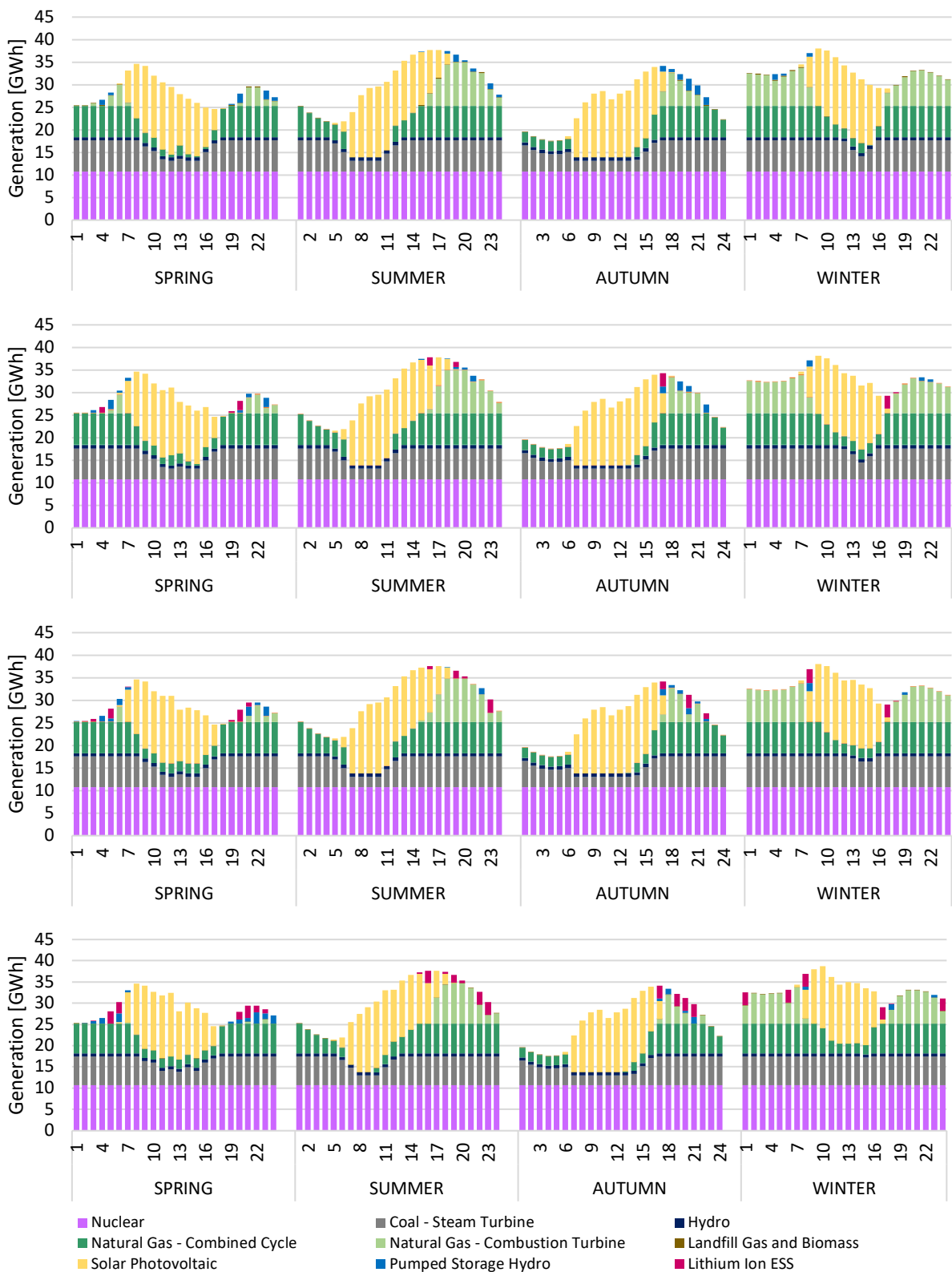
Steve	Kalland	NC State University, NC Clean Energy Technology Center
James	Kantor	ASDOTA
Bob	Kingery	Southern Energy Management
Sam	Kliewer	Cypress Creek Renewables
Kelli	Kukura	Duke Energy
Scott	Laster	Kairos Government Affairs
Evan	Lawrence	NC Utilities Commission - Public Staff
John	Lepper	IBM
Shuchi	Liu	NC State University, Electrical and Computer Engineering
Ning	Lu	NC State University, Electrical and Computer Engineering
David	Lubkeman	NC State University, Electrical and Computer Engineering
Jay	Lucas	NC Utilities Commission - Public Staff
Kevin	Martin	NC Department of Environmental Quality (DEQ)
Catie	McEntee	NC State University, Electrical and Computer Engineering
James	McLawhorn	NC Utilities Commission - Public Staff
Yao	Meng	NC State University, Electrical and Computer Engineering
Stew	Miller	Yes Solar Solutions
Sharon	Miller	Carolina Utility Customers Association, Inc. (CUCA)
Lisa	Moerner	Dominion Energy
John	Morrison	Ecoplexus, Inc.
David	Mulcahy	NC State University, Electrical and Computer Engineering
Jay	Nemeth	Oakhurst Energy Solutions
Jim	Musilek	NC Electric Membership Cooperatives
James	O'Connor	3e Enterprises Group
Larry	Ostema	Nelson Mullins, LLP
Isaac	Panzarella	NC State University, NC Clean Energy Technology Center
Autumn	Proudlove	NC State University, NC Clean Energy Technology Center
Daniel	Real	
Aaron	Reed	Solar Pack Development, Inc.
Anderson	Rodrigo de Queiroz	NC Central University, School of Business
Lee	Ragsdale	NC Electric Membership Cooperatives
PJ	Rehm	Electricities of NC
Sally	Robertson	NC WARN
Jay	Rouse	NC Electric Membership Cooperatives
Simon	Sandler	RIT
Matthew	Schultz	Duke Energy
Lisha	Sun	NC State University, Electrical and Computer Engineering

Terry	Taylor	Direct Power Inc.
Drew	Vermillion	Southeastern Transformer Company
Steve	Wall	UNC Institute for the Environment / NC Policy Collaboratory
Jim	Warren	NC WARN
Sam	Watson	NC Utilities Commission
Carl	Wilkins	Quanta Technologies
Kristen	Wills	NC WARN
TL	Winder	Nextera Energy

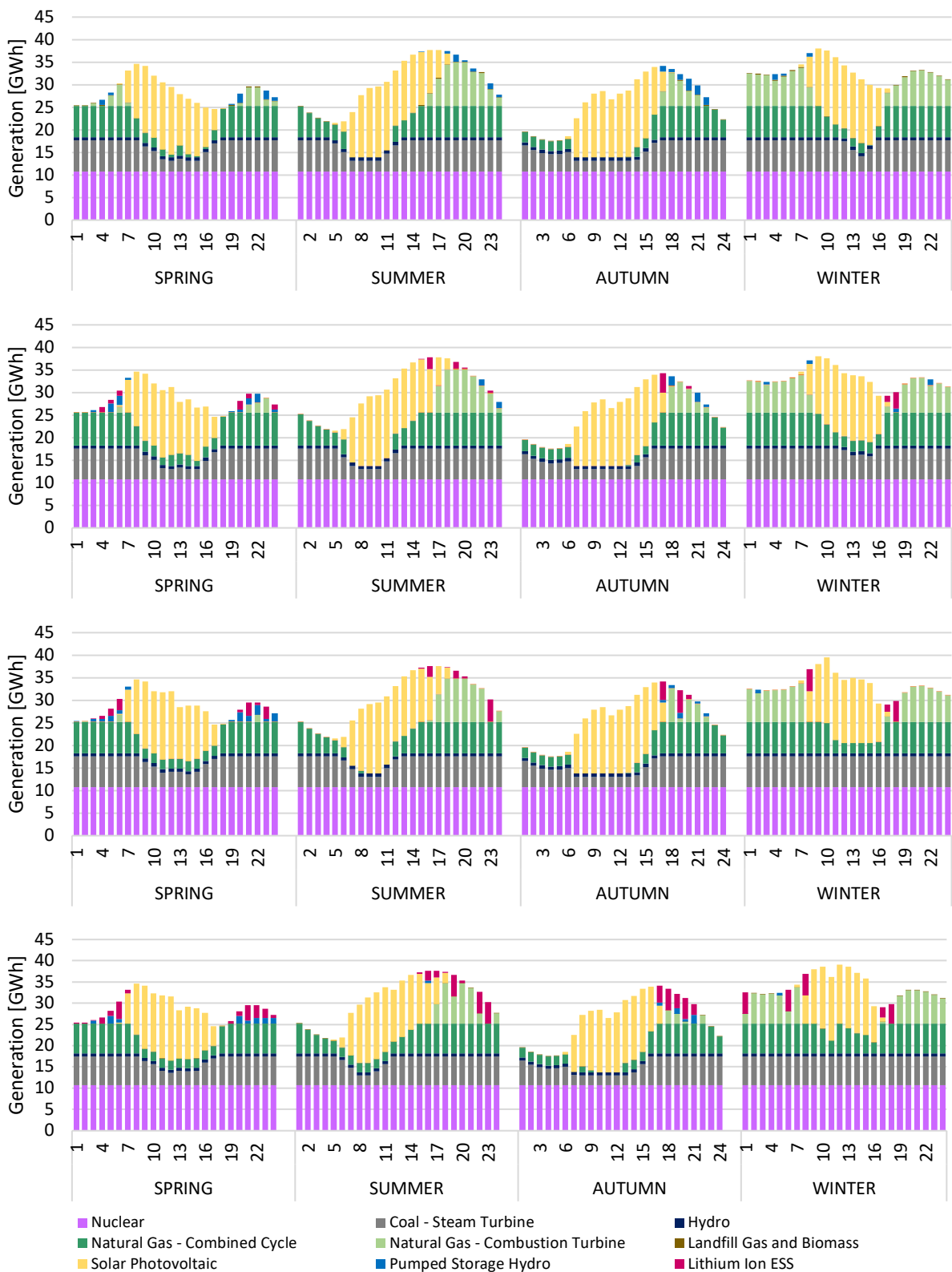
## Appendix B: Operational Model Dispatch Results



**Figure 1B.** Hourly dispatch for the peak day in each season associated with the base case in the following configurations: NS, LI-0.3GW/0.3GWh, LI-0.3GW/0.6GWh and LI-0.3GW/1.2GWh.



**Figure 2B.** Hourly dispatch for the peak day in each season associated with the base case in the following configurations: NS, LI-3GW/3GWh, LI-3GW/6GWh and LI-3GW/12GWh.



**Figure 3B.** Hourly dispatch for the peak day in each season associated with the base case in the following configurations: NS, LI-5GW/5GWh, LI-5GW/10GWh and LI-5GW/20GWh.

Hourly charge/discharge profiles for different configurations and scenarios

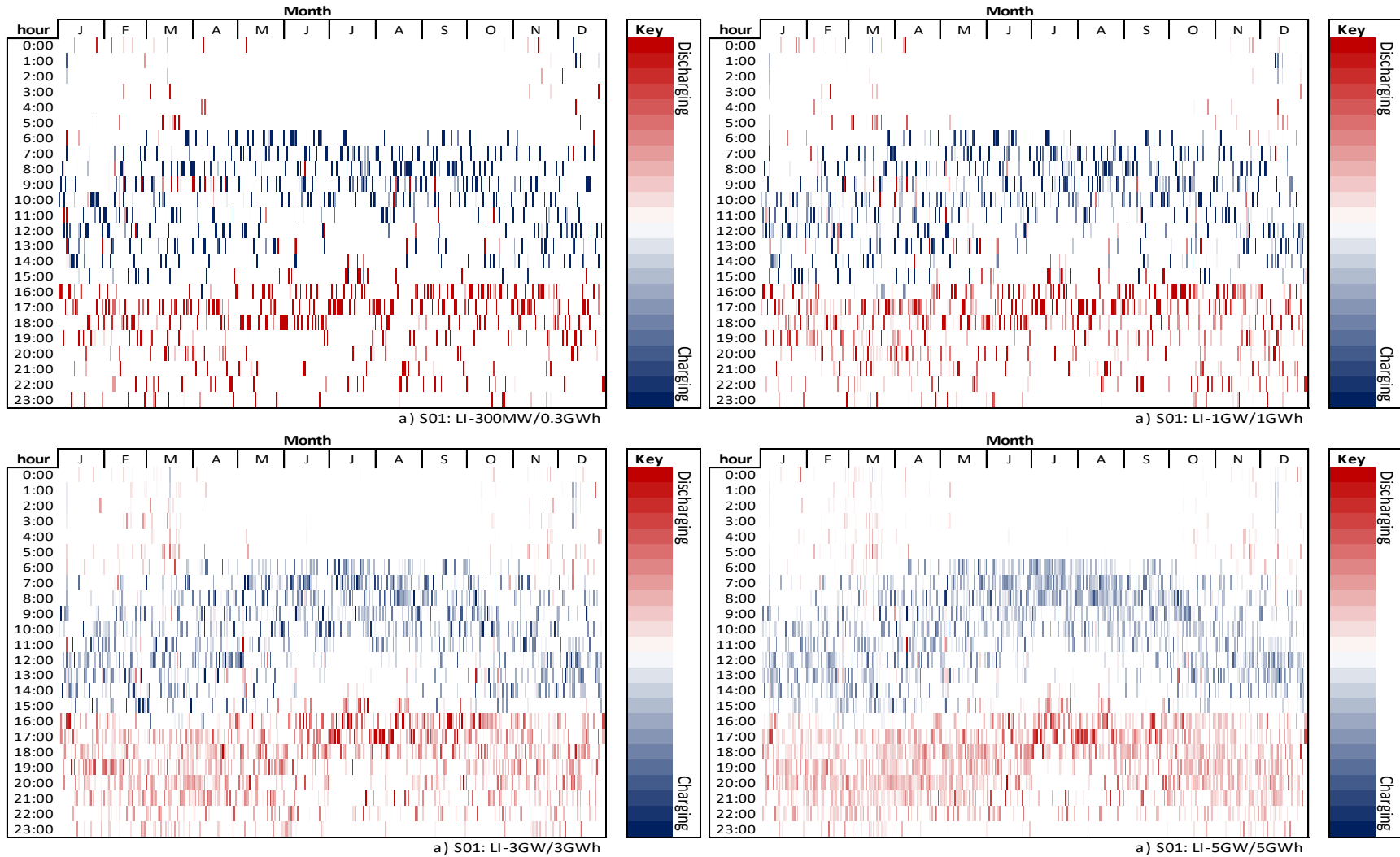
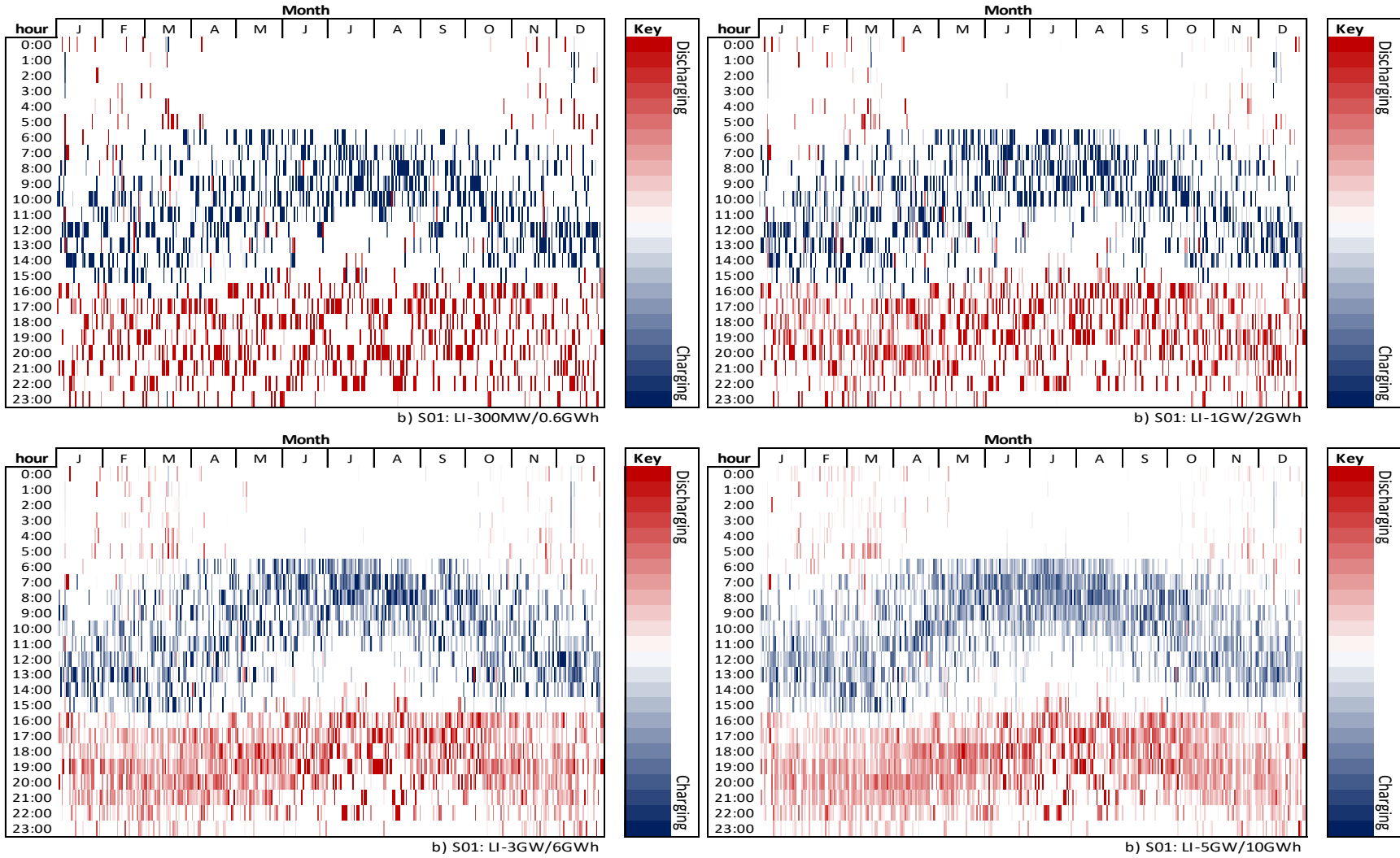
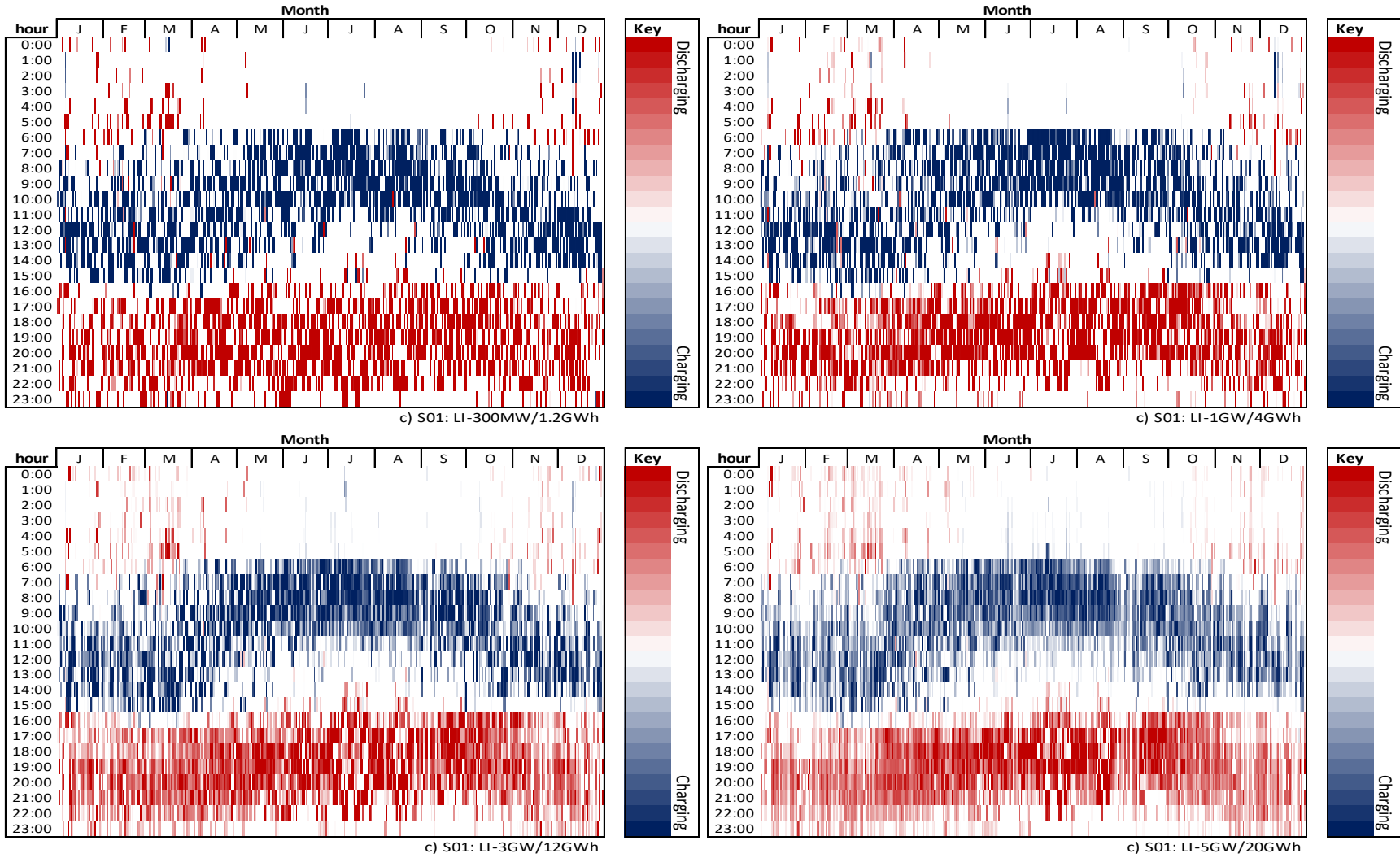


Figure 4B Hourly charge/discharge decisions for Li-ion batteries with 1 hour duration in the Base Case, assume 0.3GW/0.3GWh, 1GW/1GWh, 3GW/3GWh, 5GW/5GWh

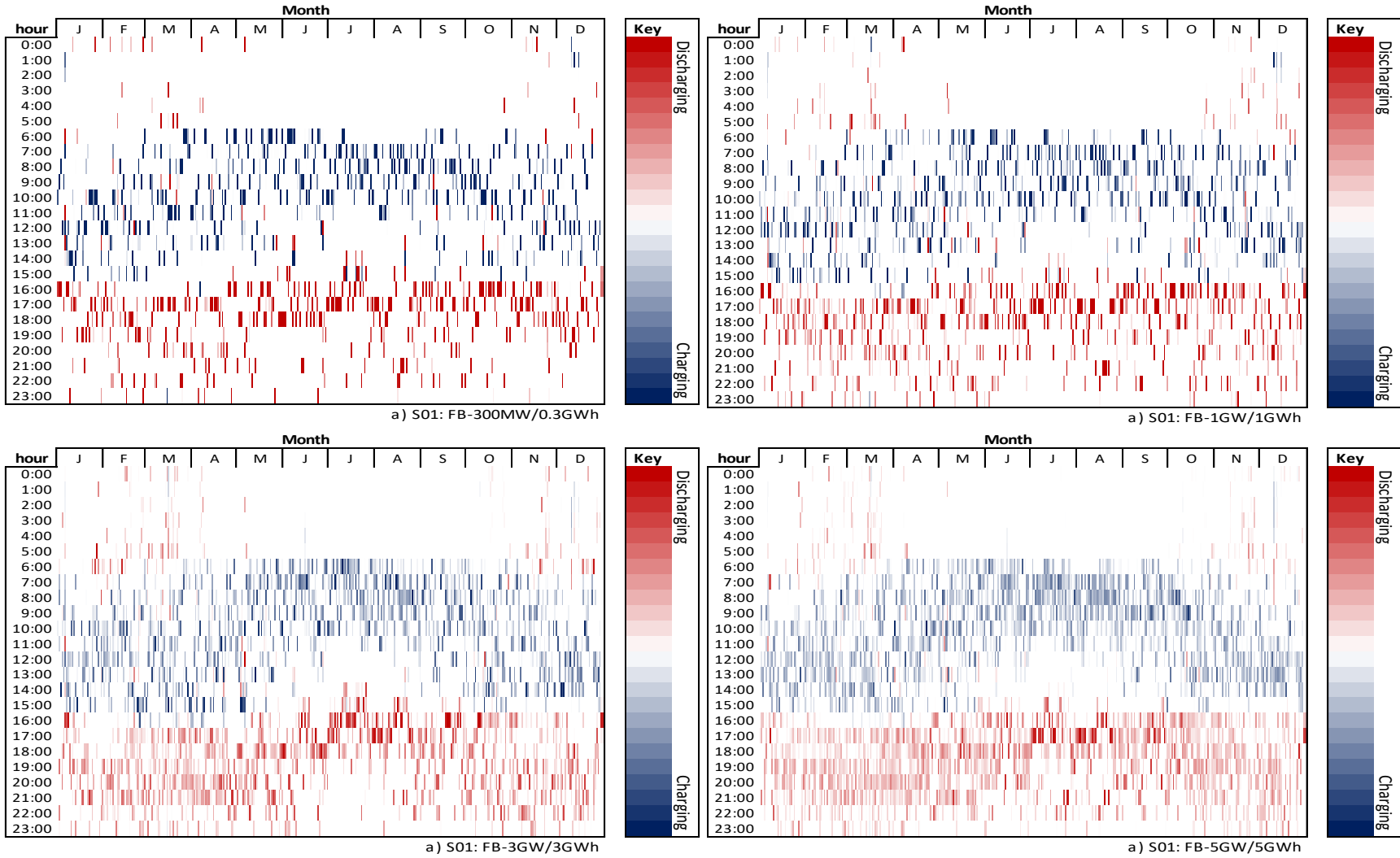




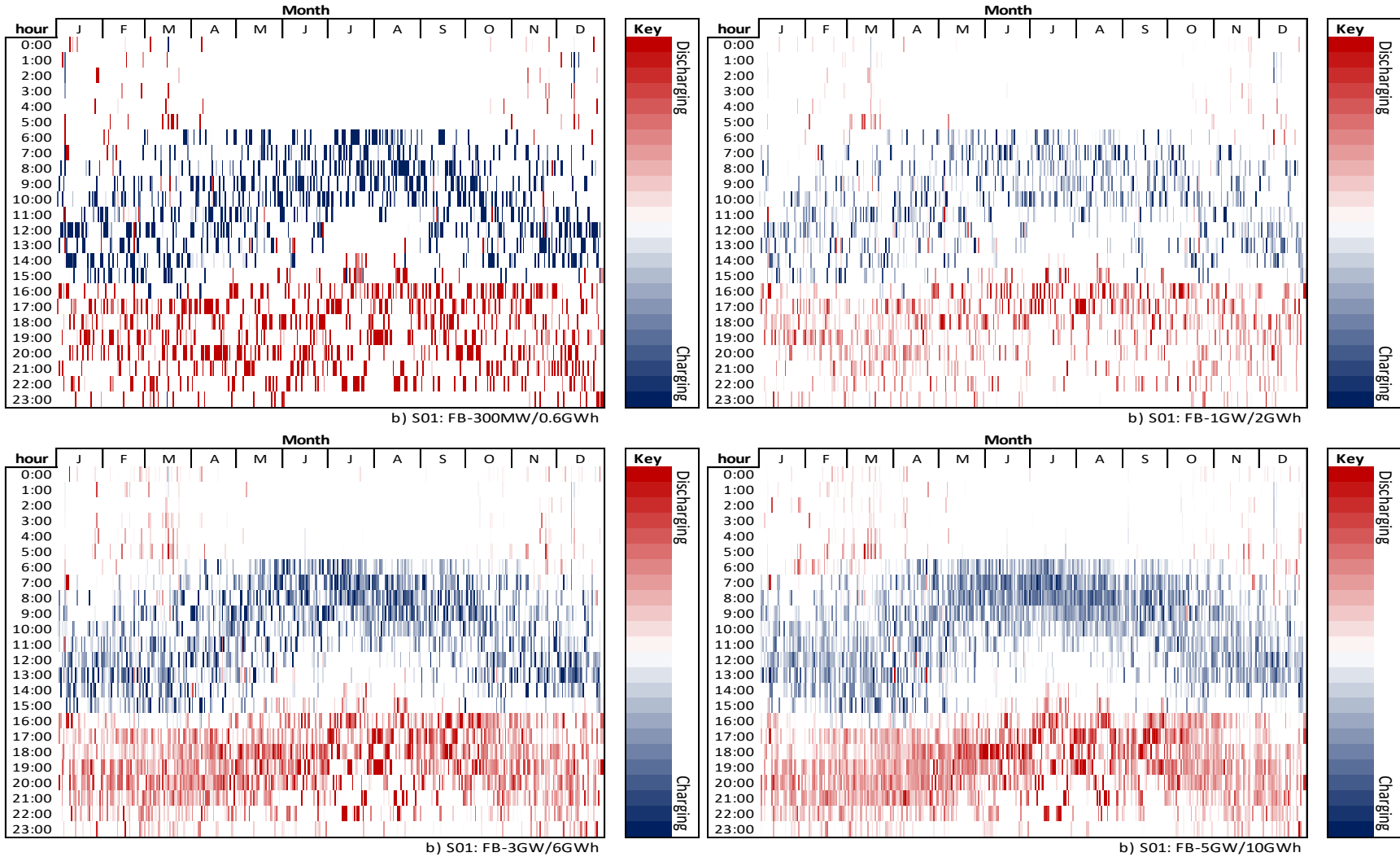
**Figure 5B** Hourly charge/discharge decisions for Li-ion batteries with 2 hour duration in the Base Case, assume 0.3GW/0.6GWh, 1GW/2GWh, 3GW/6GWh, 5GW/10GWh.



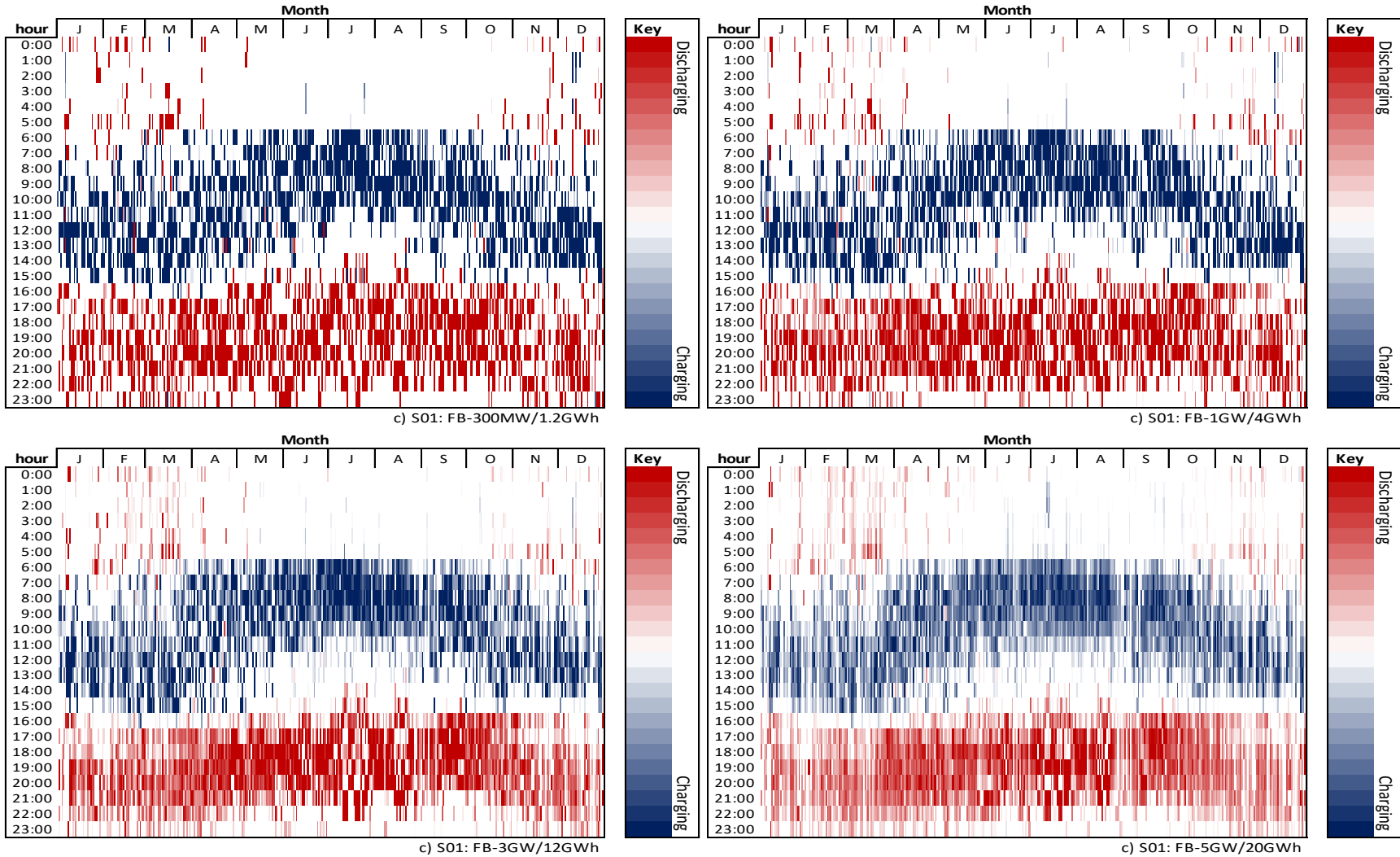
**Figure 6B** Hourly charge/discharge decisions for Li-ion batteries with 4 hour duration in the Base Case, assume 0.3GW/1.2GWh, 1GW/4GWh, 3GW/12GWh, 5GW/20GWh.



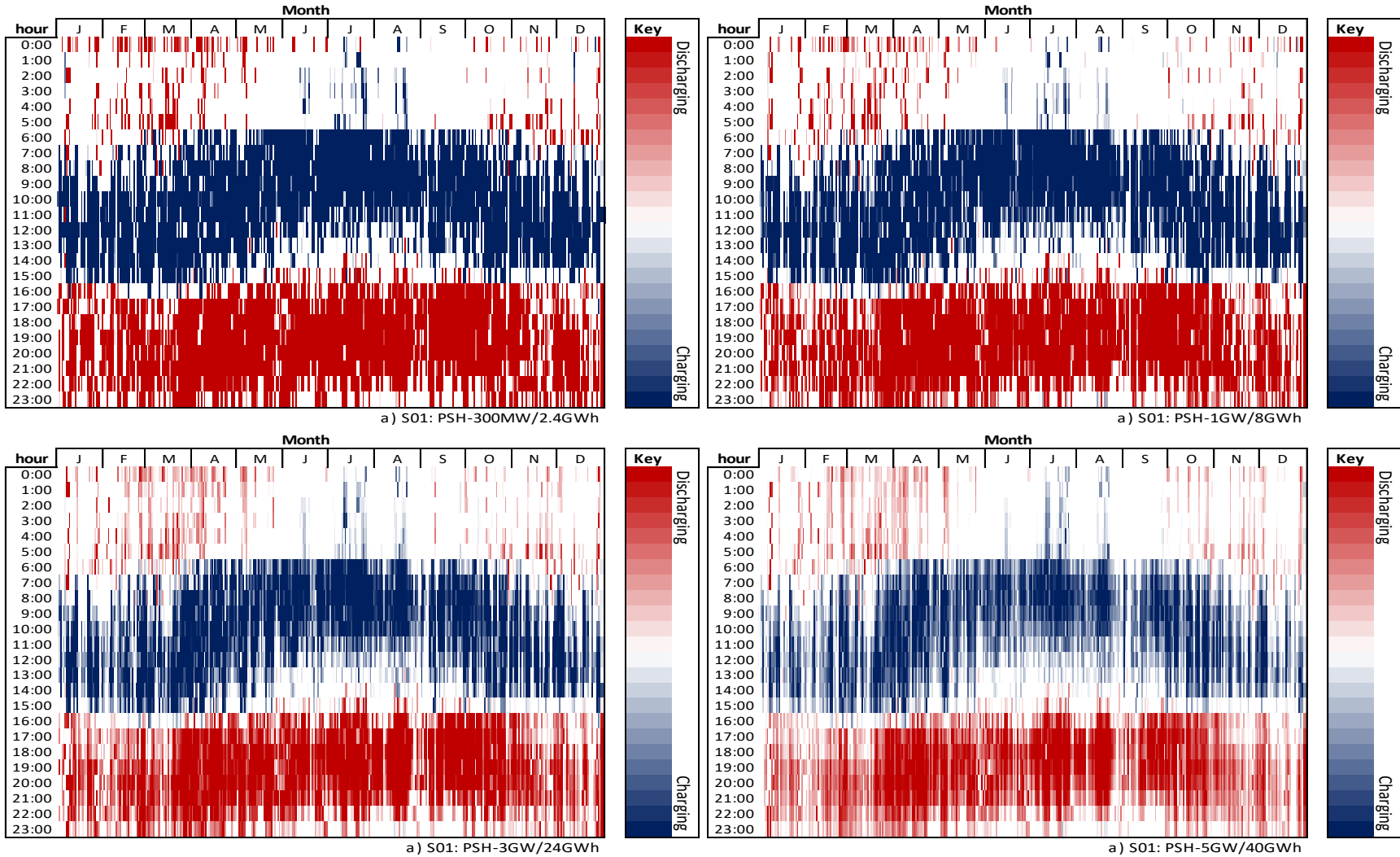
**Figure 7B** Hourly charge/discharge decisions for Flow batteries with 1 hour duration in the Base Case, assume 0.3GW/0.3GWh, 1GW/1GWh, 3GW/3GWh, 5GW/5GWh.



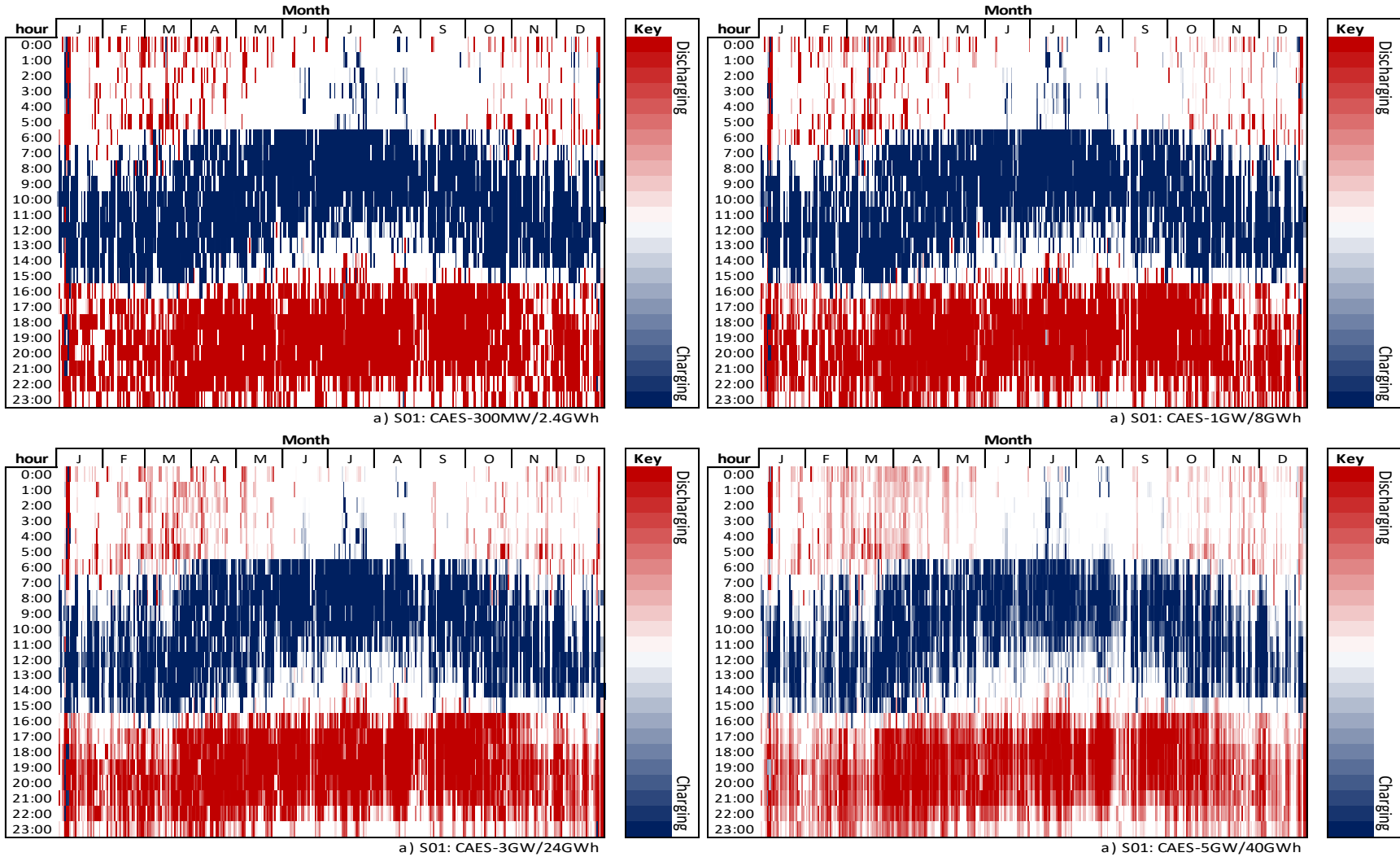
**Figure 8B** Hourly charge/discharge decisions for Flow batteries with 2 hour duration in the Base Case, assume 0.3GW/0.6GWh, 1GW/2GWh, 3GW/6GWh, 5GW/10GWh.



**Figure 9B** Hourly charge/discharge decisions for Flow batteries with 4 hour duration in the Base Case, assume 0.3GW/1.2GWh, 1GW/4GWh, 3GW/12GWh, 5GW/20GWh.



**Figure 10B.** Hourly charge/discharge decisions for Pumped Storage Hydro with 8 hour duration in the Base Case, assume 0.3GW/2.4GWh, 1GW/8GWh, 3GW/24GWh, 5GW/40GWh.



**Figure 11B.** Hourly charge/discharge decisions for Compressed Air Energy Storage with 8 hour duration in the Base Case, assume 3GW/0.3GWh, 1GW/8GWh, 3GW/24GWh, 5GW/40GWh.

## Operational Dispatch Costs and Energy Benefits for Other Scenarios

**Table 1B.** Operational dispatch costs and energy benefits in the Duke IRP case

Analysis Scenario	Operational Dispatch Simulation Case	Operational Dispatch Total Costs (\$M/year)	Energy Benefits (\$M/year)	Energy Benefits (\$/kW-year)
	S02: NS	\$12,013.7	-	-
	S02: LI-0.3GW/0.3GWh	\$12,004.3	\$9.3	\$31.13
	S02: LI-0.3GW/0.6GWh	\$11,999.5	\$14.2	\$47.27
	S02: LI-0.3GW/1.2GWh	\$11,990.6	\$23.1	\$76.93
	S02: LI-1GW/1GWh	\$11,992.7	\$20.9	\$20.93
	S02: LI-1GW/2GWh	\$11,977.2	\$36.4	\$36.42
	S02: LI-1GW/4GWh	\$11,948.8	\$64.9	\$64.88
	S02: LI-3GW/3GWh	\$11,962.0	\$51.6	\$17.22
	S02: LI-3GW/6GWh	\$11,919.7	\$93.9	\$31.31
	S02: LI-3GW/12GWh	\$11,846.8	\$166.8	\$55.61
	S02: LI-5GW/5GWh	\$11,930.2	\$83.4	\$16.68
	S02: LI-5GW/10GWh	\$11,869.2	\$144.5	\$28.90
	S02: LI-5GW/20GWh	\$11,771.3	\$242.4	\$48.48
	S02: FB-0.3GW/0.3GWh	\$12,004.6	\$9.1	\$30.25
Duke IRP	S02: FB-0.3GW/0.6GWh	\$12,000.0	\$13.7	\$45.60
	S02: FB-0.3GW/1.2GWh	\$11,991.5	\$22.1	\$73.70
	S02: FB-1GW/1GWh	\$11,993.6	\$20.1	\$20.07
	S02: FB-1GW/2GWh	\$11,978.9	\$34.7	\$34.75
	S02: FB-1GW/4GWh	\$11,952.1	\$61.6	\$61.56
	S02: FB-3GW/3GWh	\$11,964.6	\$49.1	\$16.36
	S02: FB-3GW/6GWh	\$11,925.0	\$88.7	\$29.56
	S02: FB-3GW/12GWh	\$11,857.7	\$156.0	\$52.00
	S02: FB-5GW/5GWh	\$11,934.9	\$78.7	\$15.75
	S02: FB-5GW/10GWh	\$11,875.5	\$138.2	\$27.64
	S02: FB-5GW/20GWh	\$11,790.8	\$222.9	\$44.58
	S02: PSH-0.3GW/2.4GWh	\$11,980.8	\$32.9	\$109.53
	S02: PSH-1GW/8GWh	\$11,919.9	\$93.8	\$93.78
	S02: PSH-3GW/24GWh	\$11,791.5	\$222.2	\$74.06
	S02: PSH-5GW/40GWh	\$11,723.9	\$289.7	\$57.95



**Table 2B.** Operational dispatch costs and energy benefits in the Extended REPS case

Analysis Scenario	Operational Dispatch Simulation Case	Operational Dispatch Total Costs (\$M /year)	Energy Benefits (\$M /year)	Energy Benefits (\$/kW-year)
Extended REPS	S03: NS	\$11,876.0	-	-
	S03: LI-0.3GW/0.3GWh	\$11,863.5	\$12.4	\$41.50
	S03: LI-0.3GW/0.6GWh	\$11,857.0	\$18.9	\$63.10
	S03: LI-0.3GW/1.2GWh	\$11,845.5	\$30.5	\$101.67
	S03: LI-1GW/1GWh	\$11,847.6	\$28.4	\$28.40
	S03: LI-1GW/2GWh	\$11,826.6	\$49.3	\$49.35
	S03: LI-1GW/4GWh	\$11,789.0	\$87.0	\$87.01
	S03: LI-3GW/3GWh	\$11,805.7	\$70.3	\$23.42
	S03: LI-3GW/6GWh	\$11,748.0	\$128.0	\$42.66
	S03: LI-3GW/12GWh	\$11,645.3	\$230.7	\$76.90
	S03: LI-5GW/5GWh	\$11,766.6	\$109.3	\$21.87
	S03: LI-5GW/10GWh	\$11,677.1	\$198.9	\$39.77
	S03: LI-5GW/20GWh	\$11,520.4	\$355.6	\$71.11
	S03: FB-0.3GW/0.3GWh	\$11,863.6	\$12.3	\$41.17
	S03: FB-0.3GW/0.6GWh	\$11,857.2	\$18.7	\$62.48
	S03: FB-0.3GW/1.2GWh	\$11,845.8	\$30.1	\$100.44
	S03: FB-1GW/1GWh	\$11,847.9	\$28.1	\$28.09
	S03: FB-1GW/2GWh	\$11,827.2	\$48.7	\$48.73
	S03: FB-1GW/4GWh	\$11,790.4	\$85.6	\$85.60
	S03: FB-3GW/3GWh	\$11,806.7	\$69.3	\$23.09
	S03: FB-3GW/6GWh	\$11,750.3	\$125.7	\$41.90
	S03: FB-3GW/12GWh	\$11,651.0	\$225.0	\$74.99
	S03: FB-5GW/5GWh	\$11,768.5	\$107.5	\$21.50
	S03: FB-5GW/10GWh	\$11,681.7	\$194.3	\$38.86
	S03: FB-5GW/20GWh	\$11,532.0	\$344.0	\$68.79
	S03: PSH-0.3GW/2.4GWh	\$11,829.2	\$46.7	\$155.72
	S03: PSH-1GW/8GWh	\$11,736.6	\$139.4	\$139.36
	S03: PSH-3GW/24GWh	\$11,513.3	\$362.7	\$120.90
	S03: PSH-5GW/40GWh	\$11,343.2	\$532.7	\$106.54
	S03: CAES-0.3GW/2.4GWh	\$11,839.9	36.1	\$120.2
	S03: CAES-1GW/8GWh	\$11,776.6	\$99.4	\$99.4
	S03: CAES-3GW/24GWh	\$11,618.0	\$258.0	\$86.0
	S03: CAES-5GW/40GWh	\$11,493.1	\$382.9	\$76.6

**Table 2B.** Operational dispatch costs and energy benefits in the Clean Energy Standard case

Analysis Scenario	Operational Dispatch Simulation Case	Operational Dispatch Total Costs (\$M /year)	Energy Benefits (\$M /year)	Energy Benefits (\$/kW-year)
	S04: NS	\$11,917.0	-	-
	S04: LI-0.3GW/0.3GWh	\$11,911.2	\$5.8	\$19.40
	S04: LI-0.3GW/0.6GWh	\$11,902.4	\$14.6	\$48.77
	S04: LI-0.3GW/1.2GWh	\$11,892.7	\$24.3	\$81.13
	S04: LI-1GW/1GWh	\$11,898.4	\$18.6	\$18.64
	S04: LI-1GW/2GWh	\$11,881.4	\$35.6	\$35.63
	S04: LI-1GW/4GWh	\$11,850.2	\$66.9	\$66.87
	S04: LI-3GW/3GWh	\$11,864.5	\$52.5	\$17.49
	S04: LI-3GW/6GWh	\$11,817.6	\$99.4	\$33.13
	S04: LI-3GW/12GWh	\$11,732.7	\$184.3	\$61.45
	S04: LI-5GW/5GWh	\$11,832.9	\$84.1	\$16.83
	S04: LI-5GW/10GWh	\$11,759.5	\$157.6	\$31.51
	S04: LI-5GW/20GWh	\$11,634.2	\$282.8	\$56.56
Clean Energy Standard	S04: FB-0.3GW/0.3GWh	\$11,911.0	\$6.0	\$19.92
	S04: FB-0.3GW/0.6GWh	\$11,905.9	\$11.1	\$36.93
	S04: FB-0.3GW/1.2GWh	\$11,896.6	\$20.4	\$68.07
	S04: FB-1GW/1GWh	\$11,895.5	\$21.5	\$21.47
	S04: FB-1GW/2GWh	\$11,882.4	\$34.6	\$34.65
	S04: FB-1GW/4GWh	\$11,852.4	\$64.6	\$64.61
	S04: FB-3GW/3GWh	\$11,863.2	\$53.8	\$17.92
	S04: FB-3GW/6GWh	\$11,821.6	\$95.4	\$31.81
	S04: FB-3GW/12GWh	\$11,741.4	\$175.6	\$58.53
	S04: FB-5GW/5GWh	\$11,833.2	\$83.8	\$16.76
	S04: FB-5GW/10GWh	\$11,764.0	\$153.1	\$30.61
	S04: FB-5GW/20GWh	\$11,648.8	\$268.3	\$53.65
	S04: PSH-0.3GW/2.4GWh	\$11,883.4	\$33.6	\$112.12
	S04: PSH-1GW/8GWh	\$11,811.5	\$105.5	\$105.54
	S04: PSH-3GW/24GWh	\$11,647.0	\$270.1	\$90.02
	S04: PSH-5GW/40GWh	\$11,541.5	\$375.5	\$75.11

**Table 3B.** Operational dispatch costs and energy benefits in the Carbon Cap case

Analysis Scenario	Operational Dispatch Simulation Case	Operational Dispatch Total Costs (\$M /year)	Energy Benefits (\$M /year)	Energy Benefits (\$/kW-year)
Carbon Cap	S05: NS	\$11,889.1	-	-
	S05: LI-0.3GW/0.3GWh	\$11,882.9	\$6.2	\$20.70
	S05: LI-0.3GW/0.6GWh	\$11,877.3	\$11.8	\$39.43
	S05: LI-0.3GW/1.2GWh	\$11,867.2	\$21.9	\$73.10
	S05: LI-1GW/1GWh	\$11,869.3	\$19.8	\$19.82
	S05: LI-1GW/2GWh	\$11,851.4	\$37.7	\$37.73
	S05: LI-1GW/4GWh	\$11,818.8	\$70.3	\$70.29
	S05: LI-3GW/3GWh	\$11,833.8	\$55.3	\$18.43
	S05: LI-3GW/6GWh	\$11,784.9	\$104.2	\$34.73
	S05: LI-3GW/12GWh	\$11,695.0	\$194.1	\$64.71
	S05: LI-5GW/5GWh	\$11,800.9	\$88.2	\$17.65
	S05: LI-5GW/10GWh	\$11,723.4	\$165.7	\$33.14
	S05: LI-5GW/20GWh	\$11,589.0	\$300.1	\$60.02
	S05: FB-0.3GW/0.3GWh	\$11,883.1	\$6.0	\$20.15
	S05: FB-0.3GW/0.6GWh	\$11,877.6	\$11.5	\$38.38
	S05: FB-0.3GW/1.2GWh	\$11,867.8	\$21.3	\$70.92
	S05: FB-1GW/1GWh	\$11,869.9	\$19.3	\$19.26
	S05: FB-1GW/2GWh	\$11,852.5	\$36.6	\$36.61
	S05: FB-1GW/4GWh	\$11,821.2	\$68.0	\$67.95
	S05: FB-3GW/3GWh	\$11,835.6	\$53.5	\$17.85
	S05: FB-3GW/6GWh	\$11,788.6	\$100.5	\$33.50
	S05: FB-3GW/12GWh	\$11,703.1	\$186.1	\$62.02
	S05: FB-5GW/5GWh	\$11,801.2	\$87.9	\$17.59
	S05: FB-5GW/10GWh	\$11,727.4	\$161.7	\$32.34
	S05: FB-5GW/20GWh	\$11,602.2	\$286.9	\$57.38
	S05: PSH-0.3GW/2.4GWh	\$11,853.5	\$35.6	\$118.64
	S05: PSH-1GW/8GWh	\$11,776.5	\$112.6	\$112.60
	S05: PSH-3GW/24GWh	\$11,596.7	\$292.4	\$97.46
	S05: PSH-5GW/40GWh	\$11,473.9	\$415.2	\$83.05

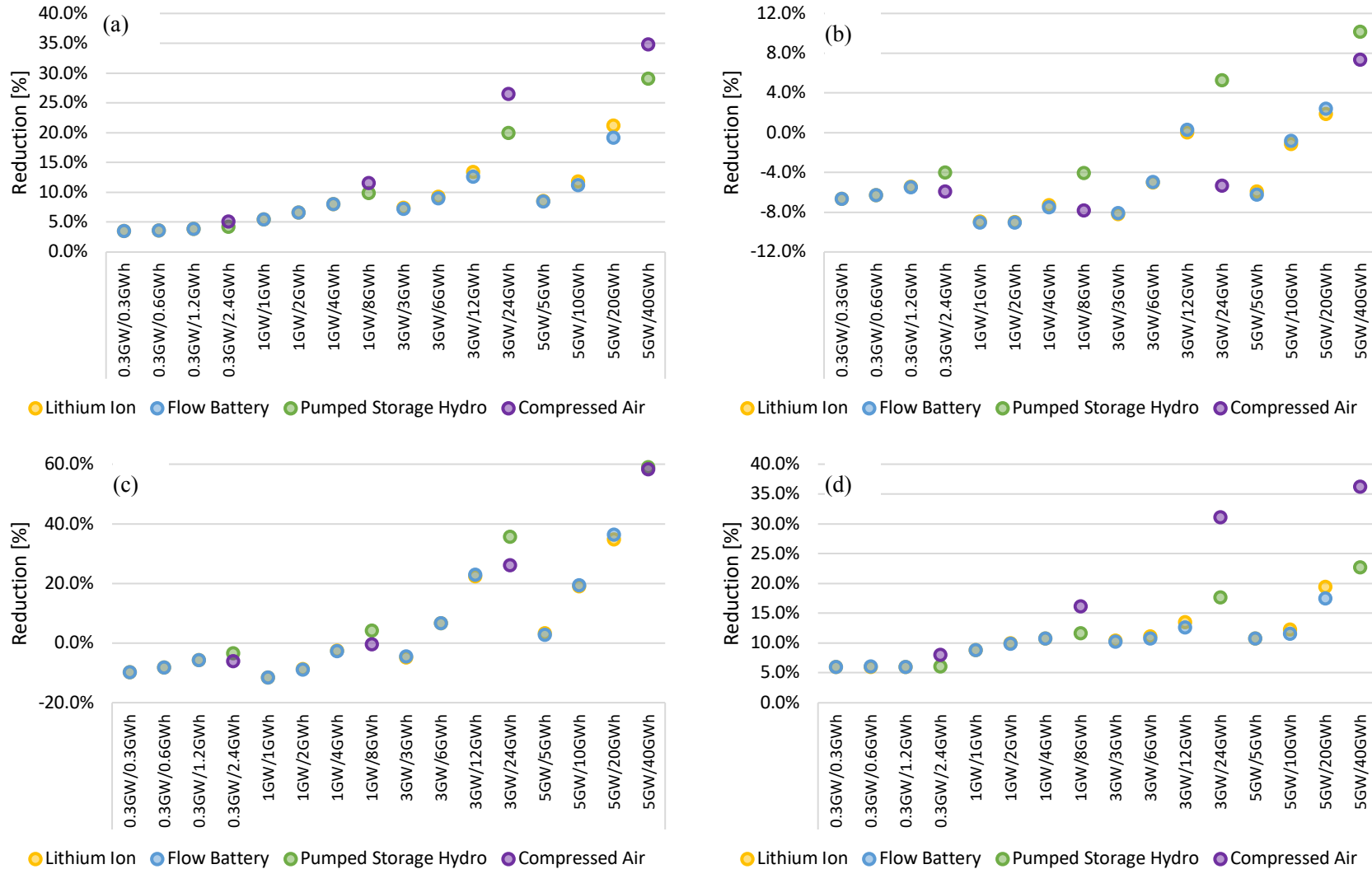
**Table 4B.** Operational dispatch costs and energy benefits in the High Natural Gas Prices case

Analysis Scenario	Operational Dispatch Simulation Case	Operational Dispatch Total Costs (\$M /year)	Energy Benefits (\$M /year)	Energy Benefits (\$/kW-year)
	S06: NS	\$12,311.7	-	-
	S06: LI-0.3GW/0.3GWh	\$12,304.7	\$7.0	\$23.37
	S06: LI-0.3GW/0.6GWh	\$12,290.1	\$21.7	\$72.27
	S06: LI-0.3GW/1.2GWh	\$12,278.3	\$33.5	\$111.60
	S06: LI-1GW/1GWh	\$12,281.0	\$30.7	\$30.69
	S06: LI-1GW/2GWh	\$12,260.8	\$51.0	\$50.97
	S06: LI-1GW/4GWh	\$12,223.7	\$88.1	\$88.07
	S06: LI-3GW/3GWh	\$12,241.2	\$70.5	\$23.51
	S06: LI-3GW/6GWh	\$12,186.2	\$125.5	\$41.85
	S06: LI-3GW/12GWh	\$12,088.6	\$223.1	\$74.36
	S06: LI-5GW/5GWh	\$12,204.1	\$107.6	\$21.52
	S06: LI-5GW/10GWh	\$12,118.7	\$193.0	\$38.60
	S06: LI-5GW/20GWh	\$11,983.7	\$328.0	\$65.61
High Natural Gas Prices	S06: FB-0.3GW/0.3GWh	\$12,305.2	\$6.5	\$21.67
	S06: FB-0.3GW/0.6GWh	\$12,299.2	\$12.5	\$41.67
	S06: FB-0.3GW/1.2GWh	\$12,288.0	\$23.7	\$79.12
	S06: FB-1GW/1GWh	\$12,287.8	\$23.9	\$23.94
	S06: FB-1GW/2GWh	\$12,268.5	\$43.2	\$43.19
	S06: FB-1GW/4GWh	\$12,233.3	\$78.4	\$78.38
	S06: FB-3GW/3GWh	\$12,245.0	\$66.8	\$22.26
	S06: FB-3GW/6GWh	\$12,198.1	\$113.6	\$37.87
	S06: FB-3GW/12GWh	\$12,107.4	\$204.3	\$68.10
	S06: FB-5GW/5GWh	\$12,214.9	\$96.8	\$19.36
	S06: FB-5GW/10GWh	\$12,135.2	\$176.5	\$35.31
	S06: FB-5GW/20GWh	\$12,013.6	\$298.2	\$59.63
	S06: PSH-0.3GW/2.4GWh	\$12,264.7	\$47.0	\$156.73
	S06: PSH-1GW/8GWh	\$12,183.2	\$128.6	\$128.56
	S06: PSH-3GW/24GWh	\$12,008.3	\$303.5	\$101.16
	S06: PSH-5GW/40GWh	\$11,913.0	\$398.8	\$79.75

**Table 5B.** Operational dispatch costs and energy benefits in the Electric Vehicles case

Analysis Scenario	Operational Dispatch Simulation Case	Operational Dispatch Total Costs (\$M /year)	Energy Benefits (\$M /year)	Energy Benefits (\$/kW-year)
	S07: NS	\$13,058.2	-	-
	S07: LI-0.3GW/0.3GWh	\$13,056.1	\$2.1	\$7.10
	S07: LI-0.3GW/0.6GWh	\$13,051.8	\$6.5	\$21.50
	S07: LI-0.3GW/1.2GWh	\$13,043.9	\$14.3	\$47.77
	S07: LI-1GW/1GWh	\$13,045.7	\$12.5	\$12.49
	S07: LI-1GW/2GWh	\$13,031.9	\$26.3	\$26.28
	S07: LI-1GW/4GWh	\$13,007.3	\$50.9	\$50.87
	S07: LI-3GW/3GWh	\$13,018.6	\$39.6	\$13.20
	S07: LI-3GW/6GWh	\$12,979.9	\$78.3	\$26.09
	S07: LI-3GW/12GWh	\$12,921.9	\$136.4	\$45.45
	S07: LI-5GW/5GWh	\$12,993.8	\$64.4	\$12.89
	S07: LI-5GW/10GWh	\$12,939.6	\$118.7	\$23.73
	S07: LI-5GW/20GWh	\$12,864.7	\$193.5	\$38.69
Electric Vehicles	S07: FB-0.3GW/0.3GWh	\$13,056.3	\$1.9	\$6.17
	S07: FB-0.3GW/0.6GWh	\$13,052.3	\$5.9	\$19.77
	S07: FB-0.3GW/1.2GWh	\$13,044.9	\$13.3	\$44.47
	S07: FB-1GW/1GWh	\$13,046.6	\$11.6	\$11.61
	S07: FB-1GW/2GWh	\$13,033.6	\$24.6	\$24.58
	S07: FB-1GW/4GWh	\$13,010.6	\$47.6	\$47.56
	S07: FB-3GW/3GWh	\$13,021.2	\$37.0	\$12.35
	S07: FB-3GW/6GWh	\$12,987.2	\$71.0	\$23.66
	S07: FB-3GW/12GWh	\$12,932.6	\$125.6	\$41.88
	S07: FB-5GW/5GWh	\$12,995.8	\$62.4	\$12.48
	S07: FB-5GW/10GWh	\$12,946.6	\$111.6	\$22.32
	S07: FB-5GW/20GWh	\$12,881.3	\$176.9	\$35.37
	S07: PSH-0.3GW/2.4GWh	\$13,036.7	\$21.5	\$71.82
	S07: PSH-1GW/8GWh	\$12,986.2	\$72.0	\$72.04
	S07: PSH-3GW/24GWh	\$12,886.2	\$172.0	\$57.35
	S07: PSH-5GW/40GWh	\$12,837.7	\$220.5	\$44.09

### Emission Reductions for other the Expanded REPS scenario



**Figure 12B.** CO<sub>2</sub> reduction as well as changes in natural gas and coal plant generation levels, by storage technology type, installed capacity, and duration. (a) Reduction in CO<sub>2</sub> emissions; (b) change in natural gas combined-cycle generation; (c) change in natural gas combustion turbine generation; change in coal steam generation. Changes are with respect to the Expanded REPS scenario without storage

## Appendix C: Description of Temoa Input Database Used for Capacity Expansion and Operational Dispatch Modeling

### 1. An Overview of the Duke Energy Carolina and Duke Energy Progress Electric Power System

In 2017, the total electricity demand in Duke Energy Carolina (DEC) and Duke Energy Progress (DEP) was 170,054 GWh, shown in Table 1C. Electricity generation and installed capacities for Duke Territory by source is provided in Table 2C. The North Carolina Energy Policy Council projects that the demand for NC electricity will grow at an annual rate of 1.2% between 2015 and 2030<sup>11</sup>, which equates to a 20% increase by 2030. Note that this growth rate is based on the Integrated Resource Plans (IRPs) of Duke Energy Progress (DEP)<sup>6</sup> and Duke Energy Carolinas (DEC)<sup>6</sup>, the two largest utilities serving North Carolina, which together provide over 70% of total electricity sales<sup>12</sup>. Dominion Energy, another utility that serves the northeastern corner of North Carolina, projects a slightly higher growth rate for its NC territory. Dominion's total electricity sales to North Carolina were 4,428 GWh in 2015<sup>12</sup>, accounting for less than 4% of North Carolina's total electricity generation. We assume that demand will increase at a yearly growth rate of 1.2% from 2015 to 2030, and the historical DEC and DEP electricity consumption in 2017 is used as the base year. Dominion territory has been excluded from the model because it would be infeasible to model all the PJM market for the sake of including 4% of the NC load. Table 1C also shows the annual electricity demand in TWh and the peak demand projections in GW for Duke Territory.

Table 1C. Annual electricity demand projections in DEC and DEP.

Period	2017	2020	2025	2030
Demand [TWh]	170	176	187	199
Peak Demand [GW]	33.6	34.8	36.9	39.2

Though DEP and DEC cover nearly all of North Carolina, there are meaningful differences in the capacity installed in each NC and SC within those territories. Table 2C includes a column describing the

percentage of the installed capacity that is within North Carolina for each technology.

Table 2C. Duke Territory capacity and electricity generation mix in 2017 <sup>a</sup>.

	System Installed Capacity (MW)	Share of the System Installed Capacity (%)	Share of the Installed Capacity in NC (%)	Generation (MWh)	Share of the System Electricity Generation (%)
Bioenergy <sup>b</sup>	709	1.42%	60.0%	902,044	0.52%
Coal <sup>c</sup>	11,695	23.34%	90.1%	34,494,198	19.82%
Oil <sup>d</sup>	727	1.45%	51.6%	0	0.00%
Hydro	2,934	5.86%	68.2%	6,620,197	3.80%
NG <sup>e</sup>	16,375	32.69%	81.3%	33,595,050	19.31%
Solar PV	2,901	5.79%	99.3%	5,513,388	3.17%
Nuclear	11,694	23.34%	43.8%	92,205,606	52.99%
Pumped Hydro	2,802	5.59%	3.1%	0	0.00%
Other	255	0.53%	36.3%	685,283	0.39%
Total	50,092	100%	69.6%	174,015,766	100%

a. Data are from EIA's Form 860 <sup>13</sup> and base case model run results.

b. Including wood/biomass steam turbines, municipal solid waste (MSW) steam turbines, landfill gas (LFG) internal combustion engines and LFG gas turbines.

c. All coal used in North Carolina is bituminous.

d. Primarily diesel oil combustion turbines.

e. Includes both combined cycle (NGCC) and combustion turbine (NGCT).

A critical challenge in the integration of renewable energy such as wind and solar PV is the variability associated with their output. To represent variations in electricity output, one year is divided into multiple time slices. The time slice is assumed to be an indivisible unit within the model, over which the electricity generation from all technologies are assumed to be constant. In addition, electricity demand varies between time slices, and must be satisfied through electricity generation. Two parameters are employed to describe the time slices: the segment fraction ( $SegFrac_{s,d}$ ) and the demand specific distributions ( $DSD_{s,d,c}$ ). The segment fraction is the fraction of one year represented by each time slice, and the demand-specific distribution represents the fraction of annual demand that falls within each time slice.

In this study, for the capacity expansion analysis, one year is divided into 96 time slices: 4 seasons, with each season including 24 times-of-day to create a representative hourly profile for each season. Since one season consists of 90 to 92 days, the number of hours in one time slice depends on the number of days in the season



where the time slice resides. The segment fraction of a time slice is given by dividing the number of hours in each time slice by the total number of hours in one year.

The demand in an individual time slice (season  $s$ , time-of-day  $d$ ) is given by averaging the hourly demands during time-of-day  $d$  over all days in season  $s$ . The hourly electricity loads are drawn from EIA data considering interchange with neighboring utilities. Note the simulated profile does not fully capture the peak load, given the use of 96 versus 8760 (hourly) time slices. The reserve margin constraint is modified from 15% real world to 40% modeled, considering this difference in peak demand for the purpose of the capacity expansion analysis.

### 1.1. Technologies and Commodities

There are two categories of energy generation technologies used in the construction of the input dataset: residual (or existing) technologies, and future technologies. Residual technologies represent electricity generating technologies that already have existing capacity in North and South Carolina. A summary of those technologies and their corresponding Temoa model name is presented in Table 3C. These data are drawn from EIA's Form 860, which annually reports all electricity generators in each state by prime mover and energy source <sup>16</sup>. Each existing electric sector generator is mapped to a specific Temoa technology, which is described in detail in Table 12C.

Single generators of like technologies are aggregated into their facilities and enumerated by their facility number and technology. A hydroelectric plant may be called HYDCONR\_5678 in the model, for instance. As power plants age and reach the end of their useful life, their capacity must be retired. We therefore construct a retirement profile, which reduces the residual capacity of each technology based on an exogenously specified schedule. Temoa is capable of differentiating age within a single technology category using vintages. The vintage represents the year in which capacity for a specific technology was put into service. Using EIA Form 860 data <sup>13</sup>, vintages were set up into 5-year bins. For example, capacity built between 1993 and 1997 (inclusive) is categorized as a 1995 vintage. For simplicity, all capacity added prior to 1958 is grouped into the 1960 vintage.

Table 3C. Capacity of residual technologies in DEC and DEP (2017) <sup>10</sup>.

Technology	Description	Capacity (MW)
EBIOSTMR	Biomass – Steam Turbine	594.4
ECOASTMR	Coal – Steam Turbine	11,649.8
EDSLCTR	Diesel – Combustion Turbine	726.7
EHYDCONR	Hydro – Conventional	2,934.3
EHYDREVR	Hydro – Pumped Storage	2,802.0
ELFGGTR	Landfill Gas – Gas Turbine	36.0
ELFGICER	Landfill Gas – Integrated Gasification	78.4
ENGACCR	Natural Gas – Combined Cycle	5,270.8
ENGACTR	Natural Gas – Combustion Turbine	11,104.3
ESOLPVR	Centralized Solar PV	2,901.4
EURNALWR	Nuclear – Light Water Reactor	11,693.8
<b>TOTAL</b>		<b>50,037.9</b>

The next step in creating a retirement profile is to specify technology lifetimes. Temoa retires the capacity associated with a given vintage if its lifetime is exceeded at the beginning of an optimization period. EIA provides data on retired power plants across the United States <sup>16</sup>, which was used to find the average age of plants that have already been decommissioned. Next, plant lifetime data from the EPA <sup>17</sup>, National Renewable Energy Laboratory (NREL) <sup>18</sup>, and MiniCam <sup>18</sup> were compared (Table 4C). No wind residual technology is specified, as the Duke territory did not have any wind capacity as of 2017. From these data, technology- and vintage-specific lifetimes were chosen for the Temoa model.

Pre-existing, technology-specific capacity split into 5-year vintage bins with the associated technology lifetimes specified for each vintage provides the requisite information needed to model retirements over the 13-year optimization time horizon. Note that we assume the lifetime of hydropower plants in the model is unlimited, since many hydropower plants built 50 to 100 years ago are still operating today and upgrades and refurbishment can facilitate generation of carbon-free, cost-effective hydroelectricity. Of the 50.1 GW of pre-existing capacity available to meet demand in 2017, 34.9 GW remains in 2030. This increasing gap between pre-existing capacity and demand must be met through the addition of new capacity.

Table 4C. Comparison of technology lifetimes in years for the US and across energy models <sup>16-18</sup>.

Technology	Avg Lifetime (entire US)	NREL	MiniCAM	EPA MARKAL	This study
EBIOSTMR	49	<b>45</b>	<b>45</b>	40	<b>45</b>
ECOASTMR	53	<b>60</b>	45	40	<b>60</b>

ECOASTMR_b	53	<b>60</b>	45	40	<b>60</b>
EDSLCTR	41	-	-	50	<b>45</b>
EHYDCONR	68	-	-	120	<b>150</b>
EHYDREVR	-	-	-	40	<b>150</b>
ELFGGTR	16	<b>30</b>	45	<b>30</b>	<b>30</b>
ELFGICER	14	<b>30</b>	45	30	<b>30</b>
ENGACCR	30	30	45	30	<b>40</b>
ENGACTR	37	30	45	30	<b>40</b>
ESOLPVR	10	<b>30</b>	<b>30</b>	<b>30</b>	<b>30</b>
EURNALWR	32	<b>60</b>	<b>60</b>	40	<b>60</b>

New capacity is added by Temoa in each period to satisfy electricity demand. For this analysis, new generation technologies were drawn from the EPA MARKAL database <sup>17</sup> and are listed in Table 5C. Technologies from this database have detailed technical and cost specifications by US Census Division and provide sufficient representation of electric generation technologies. We also consider an advanced nuclear technology and small modular reactors (SMRs). Each technology used in Temoa represents a specific fuel (e.g., coal or natural gas) and prime mover (e.g., combustion turbine or combined cycle). It is important to note that not all future technologies are currently deployed in Duke Territory, but they are made available for future investments if the model decides to deploy them. The costs and technical parameters that define each technology determine which technologies are deployed in future periods, and they will be further discussed in this document.

Table 5C. Future energy generation technologies used in NC dataset.

Technology Name	Description
ENGACC05	Natural Gas – Combined Cycle
ENGACT05	Natural Gas – Combustion Turbine
ENGAACC	Natural Gas – Advanced Combined Cycle
ENGAACT	Natural Gas – Advanced Combustion Turbine
ENGACCCCS	Natural Gas – Combined Cycle with Carbon Capture and Sequestration (CCS)
ECOALSTM	Coal – Steam Turbine
ECOALIGCC	Coal – Integrated Coal Gasification Combined Cycle
ECOALIGCCS	Coal – Integrated Coal Gasification Combined Cycle with CCS
ECOALIGCCS_b	Coal – Integrated Coal Gasification Combined Cycle with CCS, baseload
ECOALIGCC_b	Coal – Integrated Coal Gasification Combined Cycle, baseload
ECOALSTM_b	Coal – Steam Turbine, baseload
EURNALWR15	Nuclear – Light Water Reactors
EURNMSMR	Nuclear – Small Modular reactors

EBIOIGCC	Biomass – Integrated Gasification Combined Cycle
ESOLPVCEN	Solar – PV Centralized Generation (Utility scale)
ESOLPVDIS	Solar – PV Distributed Generation (rooftop solar)
EWNDON	Wind – Onshore (TRG-9)
EWNDOFS	Wind – Shallow Offshore (Generation Class 5)
ESLION	Energy storage – Lithium-ion
ESCAIR	Energy storage – Compressed air energy storage
ESZINC	Energy storage – Zinc-carbon battery
ESFLOW	Energy storage – Flow battery

The function of commodities within Temoa is to link technologies together to form a network diagram. A full list of commodities used is given for reference in Table 6C.

## 1.2. Technical Parameters

Each technology in Temoa must be supplied with a set of technical parameters that characterize its operation within each period. The properties in Table 6C broadly define the operational characteristics of each technology in a way that allows the model to meet required physical constraints. Efficiency and emission activity of a technology are linked to specific vintages of a technology, whereas the remaining parameters are the same for all vintages and through all optimization periods. Each of these technical parameters is described in turn.

Table 6C. Technical parameters used to define operation of electricity technologies in Temoa.

Parameter	Description	Source
Efficiency	The ratio of energy out of a technology to energy in (inverse to heat rate).	16,17
Availability factor	The maximum amount of electricity that can be produced in a given hourly time slice, relative to nominal capacity.	17,19,20
Capacity credit	The contribution to peak demand made by non-dispatchable technologies.	21–23
Emission factors	Kilotons of CO <sub>2</sub> , SO <sub>2</sub> , and NO <sub>x</sub> emitted per PJ of energy generated.	24
Baseload classification	Classification of a technology as a “baseload” prevents electricity generation from changing throughout the day to follow varying demand.	25
Maximum ramp rate	The maximum rate of change (%) of electricity production allowed in a power plant.	8

### 1.2.1. Baseload label

According to the EIA, baseload technologies are designed to satisfy minimum system demand, and “produce electricity at an essentially constant rate and run continuously”<sup>25</sup>. If a technology is classified as baseload, Temoa does not allow the amount of electricity generated to vary hourly within a season. The Duke Territory dataset treats nuclear as baseload, per public statements by the DEC and DEP IRPs<sup>6,7,26</sup>. In addition, both existing and future coal are split into two technologies: 40% of the residual capacity is considered baseload per eGRID data<sup>24</sup>, while the other 60% is subject to ramp rate constraints. For the new coal capacity added, Temoa will restrict its output variation within each season if it is labeled as baseload, and otherwise it will be subject to ramp rate constraints.

### 1.2.2. Efficiencies

The efficiencies for all the processes are gathered from the EPA MARKAL database<sup>17</sup> and are calibrated with EIA Assumptions to Annual Energy Outlook<sup>27</sup>. Both EPA and EIA provide efficiency estimates for each technology used in Temoa. Because the EPA data are categorized by Census Division, the data for the South Atlantic Division, where North and South Carolina are located, is used. In addition, operating data drawn from EIA Form 860<sup>13</sup> and EIA Form 923<sup>10</sup> is utilized as a more accurate estimate for the efficiencies of all existing power plants. The efficiencies are calculated at the plant level based on the rated capacities reported in EIA Form 860<sup>13</sup> and the annual electricity fuel consumption reported in EIA Form 923<sup>10</sup>. The technology-specific efficiency is then given by the weighted average efficiency over all power plants of the same technology. For example, MARKAL estimates that residual natural gas combined-cycle generators in the South Atlantic have an efficiency of 42.2%<sup>17</sup>. However, an analysis of state-level data shows an efficiency of 47.4%<sup>10</sup>. For consistency, state-level data was used to correct the efficiencies of residual technologies. Efficiencies of small modular reactors (SMRs) are taken from the Westinghouse SMR design<sup>28</sup> given its high burnup and thermal efficiency. Although Westinghouse filed bankruptcy in March 2017<sup>29</sup>, we assume that its technology plans can still be purchased by other vendors. A full listing of all technology efficiencies can be found in Table 19C.

### 1.2.3. Availability factors

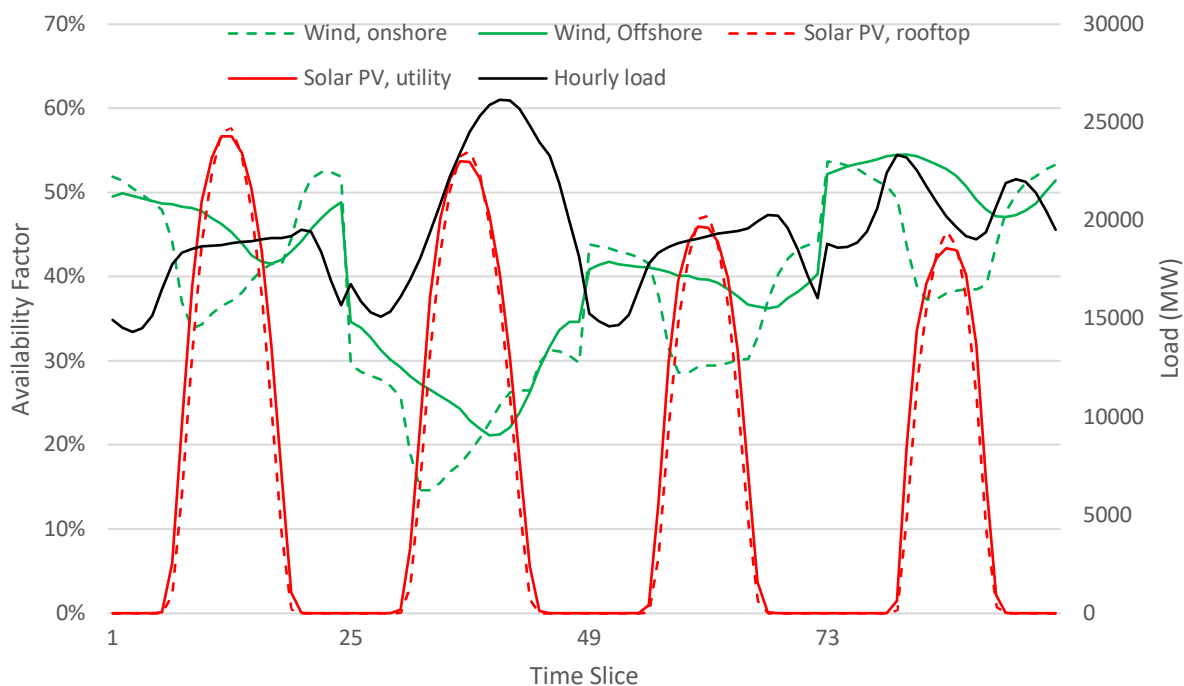
In Temoa, the availability factor serves as the upper bound on capacity factor. The capacity factor is defined as the ratio of the actual electricity production to the maximum electricity production, if it operated continuously at its full capacity. For dispatchable technologies such as fossil-fuel fired units, the availability factor is set to 90% for all time slices to reflect both forced and unforced outages. For non-dispatchable technologies such as solar and wind power, the availability factors are determined by resource availability.

In this study, for the capacity expansion analysis, the availability factors for all technologies except for wind and solar power are drawn from the EPA MARKAL database. The availability factors of wind and solar power were collected at a higher resolution due to the higher time slice resolution in this study. The data for solar PV is drawn from the NREL Solar Power Data for Integration Studies <sup>19</sup>, which consist of 1 year (2006) of 5-minute solar power and hourly day-ahead forecasts for approximately 6,000 simulated PV plants. Note that the plants are categorized into utility scale PV (UPV) and distributed PV (DPV). UPV has single axis tracking while DPV is fixed tilt equal to latitude. In addition, the data for both onshore and offshore wind power is drawn from the NREL Wind Integration National Dataset Toolkit <sup>20</sup>. Note that the availability factors for onshore wind are scaled down such that the annual equivalent capacity factor drops from 38% to 30% because both NREL <sup>34</sup> and EIA <sup>16</sup> show that the capacity factors reported by the WIND Toolkit are approximately 8% to 10% higher than real-world values in most seasons.

To convert these hourly capacity factors to the time slice capacity factors used in Temoa, first the hourly data was categorized by the season and time-of-day slices used in Temoa. The average capacity factor across all sites in North and South Carolina during a specific season and time of day slice was used in the Temoa dataset. This process resulted in the hourly capacity factor profiles for wind and solar shown in Figure 1C, with annual averages shown in Table 7C.

Table 7C. Average annual capacity factors and capacity credits for solar and wind power.

Resource Type	Technology	Average Capacity Factor	Capacity Credit
Wind	EWINDON	30.0%	20%
	EWINDOF	41.3%	20%
Solar	ESOLPVCEN	16.9%	5%
	ESOLPVDIS	15.2%	5%



**Figure 1C.** The availability factors for future solar PV and wind power used in the capacity expansion model, and the hourly demand in 2015. Time slices are numbered sequentially on the horizontal axis, and the numbers shown correspond to the first timeslice in each season, beginning with spring.

#### 1.2.4. Capacity Credits

The concept of varying contributions to peak demand relates to capacity credit, which is a measure of how much a resource is able contribute to reducing peak demand <sup>21-23</sup>. Dispatchable generation, such as coal or natural gas, usually has capacity credits close to their nameplate capacity because they can be relied upon to generate during peak periods. By contrast, wind and solar receive less capacity credit because they are not dispatchable during peak demand periods. Methods for estimating the capacity credit of renewable sources differ depending on the metric used <sup>22</sup>. In this study, the capacity credits are utilized in the reserve margin constraints, and we draw capacity credit estimates from a report that utilizes the method of Effective Load Carrying Capability (ELCC). The ELCC of a power generator represents its ability to effectively increase the generating capacity available to a utility or power grid without increasing the utility's loss of load risk <sup>35</sup>.

Although previous studies show that capacity credits are affected by factors such as location and existing renewable energy penetration, modeling capacity credits as dependent variables introduces non-linearities into the Temoa formulation. Therefore, it is assumed that capacity credits will remain constant at 20% for both onshore and offshore wind <sup>36,37</sup>, and 5% for all forms of solar PV <sup>35</sup>, summarized in Table 7C. Sioshansi et al. <sup>38</sup> show that capacity credits of electricity storage systems can be affected by hours of storage. Based on their estimates, we use 90% as the capacity credit for all storage technologies with 8 hours of storage.

### 1.2.5. Emission factors

Emission factors are primarily obtained from the EPA's MARKAL database and eGRID data <sup>24</sup>. This study considers three types of emissions: NO<sub>x</sub>, SO<sub>2</sub>, and CO<sub>2</sub>. Generators in Duke Territory were analyzed and cross-referenced to generator details found in EIA Form 860 <sup>13</sup> to calculate technology-specific emission rates. In addition, a network of emission control devices allows Temoa to install carbon capture and sequestration retrofits on coal steam plants, if necessary, to meet the carbon cap. The emission rates used in the Duke dataset are summarized in Table 8C for fossil-based generation technologies. Technologies that utilize biomass are considered carbon neutral, as most biomass generation in Duke Territory is from wood waste products <sup>10</sup>.

We assume that new pulverized coal plants will be equipped with state-of-the-art SO<sub>2</sub> and NO<sub>x</sub> removal devices and thus no future retrofitting will be required. However, existing coal plants assume uncontrolled emissions of SO<sub>2</sub> and NO<sub>x</sub>, and emission control retrofits are required to meet air quality standards. In this study, SO<sub>2</sub> removal through flue gas desulfurization (FGD) is categorized based on coal type and sulfur level, and NO<sub>x</sub> removal technologies include low NO<sub>x</sub> burners (LNB), selective non-catalytic reduction (SNCR) and selective catalytic reduction (SCR). The capacities of existing retrofit installations are drawn from the EPA eGrid database. In addition, Temoa can install carbon capture and sequestration (CCS) on both existing and new coal units to meet CO<sub>2</sub> emission limits.

Table 8C. Emission factors of all electricity generating technologies for Duke Territory.

Fossil Fuel Technology	Emission Factors (kt / PJ <sub>out</sub> )		
	CO <sub>2</sub>	NO <sub>x</sub>	SO <sub>2</sub>
ENGACTR	204	0.019	0.001



ENGA05	158	0.015	0.0008
ENGA06	126	0.012	0.0006
ENGACCR	136	0.0128	0
ENGACC05	100.25	0.0094	0
ENGAACC	93.4	0.0088	0
ENGACCCCS	11.0	0.010	0
EDSLCTR	314.3	0.487	1.605
EBIOSTMR	0	0.273	0.790
EBIOIGCC	0	0.196	0.104
ECOALSTM	227.887	0.892	3.057
ECOALSTM w/ CCS	34.124	0.892	3.057
ECOALIGCC	33.847	0.883	3.026
ECOALIGCCS	10.754	0.842	2.886
ECOASTMR	251.193	0.983	3.369

## 2. Costs

Temoa minimizes the total present cost, which is broken into three main components: investment costs, fixed costs, and variable costs (salvage value is derived from investment costs). Investment costs represent the initial capital outlay plus loan costs needed to build new capacity, fixed costs represent operations and maintenance costs that are independent of generation level, and variable costs include operational expenses that are dependent on the generation level. Variable costs are also used to specify fuel commodity prices.

Cost estimates for all three categories were obtained from several sources, but primarily from the NREL ATB database. For the purposes of this model, costs from the South Atlantic region were used for Duke.

Investment costs in the NREL ATB dataset are in units of dollars per kilowatt (\$/kW), in 2017 dollars. The costs used in our model dataset are also 2017 constant dollars. When a technology is deployed, Temoa assumes that the capacity added is available at the beginning of the period in which the costs are incurred. A full listing of new technologies and their investment costs can be found in 14C

Fixed costs are incurred annually and specified in units of dollars per kilowatt-year (\$/kWyr), while variable costs are proportional to electricity generated and specified in units of million dollars per petajoule (M\$/PJ). Most variable and fixed costs are drawn from the EPA's MARKAL database following the same

methodology as discussed above. A complete listing of fixed and variable O&M costs can be found in Table 15C – Table 17C. The costs and technical parameters described above were used to create the baseline dataset for the Duke Territory.

### 3. Scenario Specific Parameters

As mentioned in Section 6.5 of this report, in addition to the base scenario, six (6) other scenarios, described below, were meant to serve as realistic alternative buildouts. These scenarios are also run to be cost optimal but have further constraints or varying data. The scenarios are listed and described briefly in Table 9C, below.

Table 9C. Scenarios and Description.

Scenario	Description
Scenario 01 – Base Case	Business as usual, no modifications
Scenario 02 – Duke IRP	Buildout according to Duke IRP 2017
Scenario 03 – Expanded REPS	40% NC demand met by “Renewables” in 2030
Scenario 04 – Clean Energy Standard	60% NC demand met by “Clean Energy” in 2030
Scenario 05 – Carbon Cap	40% reduction of 2015 emissions by 2030
Scenario 06 – High Natural Gas Price	EIA AEO high natural gas price forecast
Scenario 07 – Electric Vehicle	7.3 TWh demand in 2030 by EV

The 2017 DEC and DEP IRPs calls for 3.3 GW of centralized solar PV, 25MW of nuclear expansion, 495MW of natural gas CC and 221MW of natural gas CT moving into 2030. Scenario 02 forces the model to build this capacity using a minimum capacity constraint in given years.

The Expanded Renewable Energy Portfolio Standards (REPS) scenario utilizes a minimum activity constraint, where a renewable energy commodity, energy coming from wind, solar, biomass and geothermal, is required to meet 40% of North Carolina demand by 2030. This activity moves linearly from existing activity, 6% in 2017.

The Clean Energy Standard scenario handles meeting demand with clean energy in a similar way. “Clean energy” encompasses all the renewables mentioned in Scenario 03 as well as nuclear and hydroelectric, and the activity from clean energy must meet 60% of North Carolina demand in 2030. There is a linear

interpolation from present values in 2017.

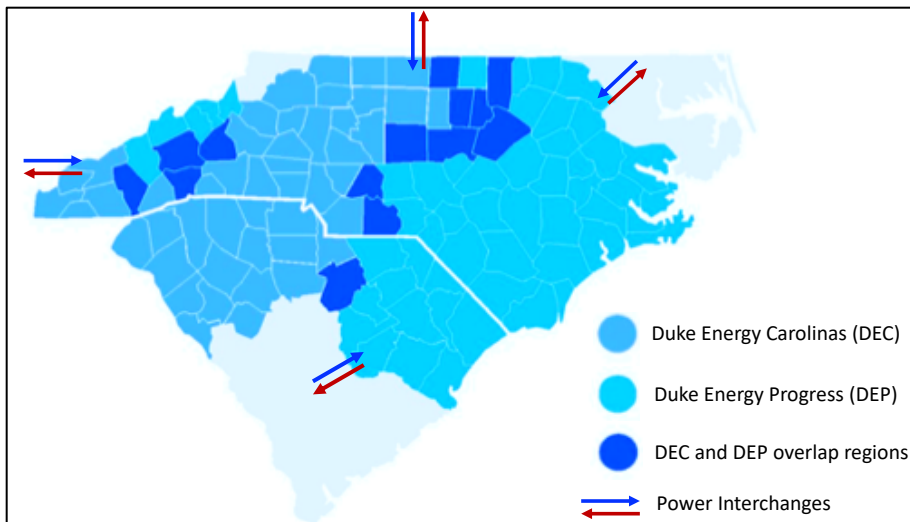
The Carbon Cap scenario makes use of a constraint called Emission Limit, which in all scenarios restricts NO<sub>x</sub> and SO<sub>2</sub>. This scenario also creates a cap on carbon emissions, limited to a 60% (40% reduction) of 2015 levels by 2030, linearly interpolated for years between.

The High Natural Gas Price scenario utilizes the Energy Information Administration (EIA) Annual Energy Outlook (AEO) high prediction for natural gas prices through 2030 (7.18 M\$/PJ), where all other scenarios use the middle prediction price (4.77 M\$/PJ).

The Electric Vehicle scenario assumes high implementation of electric vehicles, which total 7.3 TWh demand in 2030. The hourly distribution of additional demand is drawn from an article in Nature Energy<sup>57</sup> and adds largely to evening hours, little to the early morning hours.

#### **4. Operation Model Parameters**

The Temoa model was further utilized to perform operational model runs, simulating activity over 8760 time slices – all hours of the year 2030. The capacity expansion model, described previously, utilizes four seasons' average demand profile for 24 hours each, totaling 96 time slices and accommodates multiple years. The operational model considers a single season of 8,760 unique hourly demands over one year horizon. The demand profile is drawn from EIA US Electric System Operating Data <sup>60</sup> for DEC and DEP regions, subtracting net import and adding net export out of the territories for 2017. This profile is scaled according to the demand projected in 2030. Figure 2C presents a basic illustration of the Carolina's power system modeled in Temoa.



**Figure 2C.** Illustration of the Carolinas power system represented in Temoa for the Capacity Expansion and Operational Dispatch Analysis.

Operational model runs were performed for each analysis scenario described earlier, with and without the presence of energy storage devices. The operational model runs are conducted for each of the buildout plans (i.e., the output of the capacity expansion model) to represent the system in 2030. Generators that reach the end of their lifetime before 2030 are removed from the set of available generation technologies in 2030 and new generation is added according to the capacity expansion model results, primarily centralized solar and natural gas combined cycle and natural gas combustion turbine plants. The newly implemented technologies used fixed and variable costs according to their respective ‘future tech’ classes. For instance, new centralized solar uses fixed and variable costs of ESOLPVCEN. Table 10C shows the additional capacity across scenarios from the capacity expansion runs that are added as existing technologies in the operation model.

Table 10C. Additional Capacity in 2030 [GW].

Scenario	Centralized Solar PV	Natural Gas Combined Cycle	Natural Gas Combustion Turbine
S01 – Base Case	13.74	2.44	0.0
S02 – Duke IRP	13.10	2.24	0.22
S03 – Expanded REPS	24.74	1.87	0.0
S04 – Clean Energy Std.	17.18	2.24	0.0
S05 – Carbon Cap	19.23	2.16	0.0
S06 – High Nat. Gas Price	13.72	2.44	0.0

S07 – Electric Vehicle	12.37	4.94	0.0
------------------------	-------	------	-----

Temoa uses CapacityFactorTech to define the share of capacity available for resource adequacy. The operational model used this CapacityFactorTech profiles for wind and solar across all time slices to define the production profile of each. We note that no profile was necessary to be created for wind, since there was no deployments of the technology from the outputs of the capacity expansion runs. The profile for solar was generated using NREL System Advisor Model (SAM)<sup>58</sup>, aggregated for Asheville, Charlotte, Greensboro, Raleigh and Wilmington assuming 0° tilt, single axis tracker with backtracking ( $\pm 60^\circ$ ), 1.3 DC/AC ratio. All other technologies' factors were held constant according to their NERC Generating Availability Data System (GADS) demand equivalent forced outage rate (EFORd)<sup>59</sup>. These factors are shown in Table 11C. To alleviate some computational burden, the capacities of these existing technologies were de-rated according to their EFORd factor.

Table 11C. List of de-rating factors for all residual technologies except wind and solar.

Technology	EFORd
EBIOTMR	0.90
ECOASTMR	0.92
EHYDCONR	0.25
EHYDREVR	0.96
ELFGGTR	0.91
ELFGICER	0.91
ENGACCR	0.96
ENGACTR	0.91
EURNALWR	0.98

Energy storage was added to the models after an initial run without storage. Storage technologies considered include lithium-ion batteries (ESLION in Temoa), flow batteries (ESFLOW), pumped storage hydro (ESPUMP) and compressed air energy storage (ESCAES). The assumed roundtrip efficiencies are 0.85, 0.75, 0.75 and 1.5, respectively. An array of storage technology capacity versus duration model runs were generated for each analysis scenario. All storage technologies in all scenarios had 0.3GW, 1GW, 3GW and 5GW of capacity. Lithium-ion and flow batteries ran with 1 hour, 2 hour and 4 hour durations while pumped storage

hydro and compressed air energy storage ran with 8 hour duration.

## 5. References

- (1) Hunter, K.; Sreepathi, S.; DeCarolis, J. F. Modeling for Insight Using Tools for Energy Model Optimization and Analysis (Temoa). *Energy Econ.* **2013**, *40*, 339–349.
- (2) North American Electric Reliability Corporation. *NERC Reliability Metrics Specifications Sheet*; North American Electric Reliability Corporation, Washington, DC, 2009.
- (3) North American Electric Reliability Cooperation. *Summer Reliability Assessment*; North American Electric Reliability Cooperation, Washington, DC, 2016.
- (4) North Carolina General Assembly. § 62-110.1. *Certificate for Construction of Generating Facility; Analysis of Long-Range Needs for Expansion of Facilities; Ongoing Review of Construction Costs; Inclusion of Approved Construction Costs in Rates.*; Raleigh, North Carolina, 1963.
- (5) North Carolina Utilities Commission. *R08-60: Integrated Resource Planning and Filings*; Raleigh, North Carolina.
- (6) Duke Energy Progress. *North Carolina Integrated Resource Plan (Biennial Report)*; Duke Energy Progress, Raleigh, North Carolina, 2016.
- (7) Duke Energy Carolinas. *South Carolina Integrated Resource Plan (Biennial Report)*; Duke Energy Carolinas, Raleigh, North Carolina, 2016.
- (8) Krall, E.; Higgins, M.; O'Neill, R. P. *RTO Unit Commitment Test System*; Federal Energy Regulatory Commission, Washington, DC, 2012.
- (9) Domenichini, R.; Mancuso, L.; Ferrari, N.; Davison, J. Operating Flexibility of Power Plants with Carbon Capture and Storage (CCS). *Energy Procedia* **2013**, *37*, 2727–2737.
- (10) US Energy Information Administration. *Net Generation by State by Type of Producer by Energy Source (ELA-906, ELA-920, and ELA-923)*; US Energy Information Administration, Washington, DC, 2017.
- (11) Lt. Governor Dan Forest. *Energy Policy Council Report*; North Carolina Department of Environmental Quality, Raleigh, North Carolina, 2016.
- (12) US Energy Information Administration. *Form-861: Annual Electric Power Industry Report*; US Energy Information Administration, Washington, DC, 2016.
- (13) US Energy Information Administration. Form EIA-860 detailed data <https://www.eia.gov/electricity/data/eia860/> (accessed Aug 1, 2015).
- (14) US Energy Information Administration. State Electricity Profiles 2017 <http://www.eia.gov/electricity/state/northcarolina/> (accessed Jan 1, 2017).
- (15) Federal Energy Regulatory Commission. Form No. 714 - Annual Electric Balancing Authority Area and Planning Area Report <http://www.ferc.gov/docs-filing/forms/form-714/data.asp> (accessed Aug 1, 2016).
- (16) US Energy Information Administration. *Electric Power Monthly*; Washington, DC, 2015.
- (17) Shay, C.; Gage, C.; Johnson, T.; Loughlin, D.; Dodder, R.; Kaplan, O.; Vijay, S.; Carroll, C.; Gamas, J.; DeCarolis, J. *EPA US Nine Region MARKAL Database: Database Documentation*; US Environmental Protection Agency, Washington, DC., 2008.
- (18) Tidball, R.; Bluestein, J.; Rodriguez, N.; Knoke, S. *Cost and Performance Assumptions for Modeling Electricity Generation Technologies*; ICF International, Fairfax, VA (United States), 2010.

- (19) National Renewable Energy Laboratory. *Solar Power Data for Integration Studies*; National Renewable Energy Laboratory. Golden, CO, 2006.
- (20) National Renewable Energy Laboratory. *The Wind Prospector*; National Renewable Energy Laboratory. Golden, CO, 2016.
- (21) International Energy Agency. *Modelling the Capacity Credit of Renewable Energy Sources*; International Energy Agency, Paris, France, 2011.
- (22) Madaeni, S. H.; Sioshansi, R.; Denholm, P. *Comparison of Capacity Value Methods for Photovoltaics in the Western United States*; National Renewable Energy Laboratory (NREL), Golden, CO., 2012.
- (23) Mosadeghy, M.; Yan, R.; Saha, T. K. A Time-Dependent Approach to Evaluate Capacity Value of Wind and Solar PV Generation. *IEEE Trans. Sustain. Energy* **2016**, *7* (1), 129–138.
- (24) US Environmental Protection Agency. *The Emissions & Generation Resource Integrated Database: Technical Support Document for the 9th Edition of EGRID with Year 2010 Data*; Bethesda, MD, 2014.
- (25) US Energy Information Administration. Glossary of Terms <https://www.eia.gov/tools/glossary> (accessed Jul 1, 2017).
- (26) Matyi, B. Duke's Rogers Pessimistic about New Coal - Fired Generation ; Nuclear ' First Choice' for Baseload. *Electr. Util. Week* **2007**.
- (27) US Energy Information Administration. Annual Energy Outlook 2017. 2017.
- (28) International Atomic Energy Agency. *Advances in Small Modular Reactor Technology Developments*; Vienna, Austria, 2014.
- (29) Cardwell, D.; Soble, J. Bankruptcy Rocks Nuclear Industry. *The New York Times*. New York, NY March 30, 2017, p B1.
- (30) Cole, W. J.; Marcy, C.; Krishnan, V. K.; Margolis, R. Utility-Scale Lithium-Ion Storage Cost Projections for Use in Capacity Expansion Models. In *2016 North American Power Symposium (NAPS)*; 2016; pp 1–6.
- (31) Lazard. Lazard's Levelized Cost of Storage - Version 2.0 <https://www.lazard.com/media/438042/lazard-levelized-cost-of-storage-v20.pdf> (accessed Jun 28, 2018).
- (32) Skyllas-Kazacos, M.; Chakrabarti, M. H.; Hajimolana, S. A.; Mjalli, F. S.; Saleem, M. Progress in Flow Battery Research and Development. *J. Electrochem. Soc.* **2011**, *158* (8), R55--R79.
- (33) Díaz-González, F.; Sumper, A.; Gomis-Bellmunt, O.; Villafáfila-Robles, R. A Review of Energy Storage Technologies for Wind Power Applications. *Renew. Sustain. Energy Rev.* **2012**, *16* (4), 2154–2171.
- (34) King, J.; Clifton, A.; Hodge, B.-M. *Validation of Power Output for the WIND Toolkit*; National Renewable Energy Laboratory, Golden, CO, 2014.
- (35) Perez, R.; Margolis, R.; Kmiciek, M.; Schwab, M.; Perez, M. *Update: Effective Load-Carrying Capability of Photovoltaics in the United States; Preprint*; National Renewable Energy Laboratory, Golden, CO, 2006.
- (36) Keane, A.; Milligan, M.; Dent, C. J.; Hasche, B.; D'Annunzio, C.; Dragoon, K.; Holtinen, H.; Samaan, N.; Soder, L.; O'Malley, M. Capacity Value of Wind Power. *IEEE Trans. Power Syst.* **2011**, *26* (2), 564–572.
- (37) Holtinen, H.; Meibom, P.; Orths, A.; Van Hulle, F.; Lange, B.; O'Malley, M.; Smith, J. C.; Estanqueiro, A.; Ricardo, J.; Ummels, B. C.; et al. Design and Operation of Power Systems with Large Amounts of Wind Power: Final Report, Phase One 2006-08, IEA WIND Task 25. *Design and operation of power systems with large amounts of wind power: Final report, Phase one 2006-08, IEA WIND Task 25*. VTT 2009.
- (38) Sioshansi, R.; Madaeni, S. H.; Denholm, P. A Dynamic Programming Approach to Estimate the Capacity Value of Energy Storage. *IEEE Trans. Power Syst.* **2014**, *29* (1), 395–403.

- (39) US Energy Information Administration. Natural Gas 1998 Issues and Trends [http://www.eia.gov/pub/oil\\_gas/natural\\_gas/analysis\\_publications/natural\\_gas\\_1998\\_issues\\_trends/pdf/it98.pdf](http://www.eia.gov/pub/oil_gas/natural_gas/analysis_publications/natural_gas_1998_issues_trends/pdf/it98.pdf) (accessed Aug 2, 2016).
- (40) US Environmental Protection Agency. Clean Air Markets - Programs <https://www.epa.gov/airmarkets/clean-air-markets-programs> (accessed Jan 1, 2017).
- (41) North Carolina Department of Environment and Natural Resources. Clean Air Legislation: Clean Smokestacks Act <http://deq.nc.gov/about/divisions/air-quality/air-quality-outreach/news/clean-air-legislation> (accessed Jan 19, 2017).
- (42) US Energy Information Administration. Power plant emissions of sulfur dioxide and nitrogen oxides continue to decline in 2012 <http://www.eia.gov/todayinenergy/detail.cfm?id=10151> (accessed Aug 2, 2016).
- (43) Li, Y.-R.; Gibson, J. M. Health and Air Quality Benefits of Policies to Reduce Coal-Fired Power Plant Emissions: A Case Study in North Carolina. *Environ. Sci. Technol.* **2014**, *48* (17), 10019–10027.
- (44) US Environmental Protection Agency. Acid Rain Program <https://www.epa.gov/airmarkets/acid-rain-program> (accessed Aug 2, 2016).
- (45) US Environmental Protection Agency. Cross-State Air Pollution Rule <https://www.epa.gov/csapr> (accessed Jan 1, 2017).
- (46) US Environmental Protection Agency. Cross-State Air Pollution Rule (CSAPR) State Budgets, Variability Limits, and Assurance Levels <https://www.epa.gov/csapr/cross-state-air-pollution-rule-csapr-state-budgets-variability-limits-and-assurance-levels> (accessed Jul 1, 2017).
- (47) North Carolina Utilities Commission. Renewable Energy and Energy Efficiency Portfolio Standard (REPS) <http://www.ncuc.commerce.state.nc.us/reps/reps.htm> (accessed Aug 1, 2016).
- (48) U.S. Internal Revenue Service. Business Energy Investment Tax Credit (ITC) <http://programs.dsireusa.org/system/program/detail/658> (accessed Jul 1, 2017).
- (49) U.S. Bureau of Labor Statistics. *Consumer Price Index for All Urban Consumers (CPI-U)*; U.S. Bureau of Labor Statistics, Washington, DC, 2016.
- (50) US Energy Information Administration. *Updated Capital Cost Estimates for Utility Scale Electricity Generating Plants*; US Energy Information Administration, Washington, DC, 2013.
- (51) National Renewable Energy Laboratory. 2017 ATB <https://atb.nrel.gov/electricity/2017/> (accessed Jun 27, 2018).
- (52) Fu, R.; Feldman, D. J.; Margolis, R. M.; Woodhouse, M. A.; Ardani, K. B. *US Solar Photovoltaic System Cost Benchmark: Q1 2017*; National Renewable Energy Laboratory, Golden, Colorado, 2017.
- (53) National Renewable Energy Laboratory. Wind Maps <https://www.nrel.gov/gis/wind.html> (accessed Jun 27, 2018).
- (54) Carelli, M. D.; Garrone, P.; Locatelli, G.; Mancini, M.; Mycoff, C.; Trucco, P.; Ricotti, M. E. Economic Features of Integral, Modular, Small-to-Medium Size Reactors. *Prog. Nucl. Energy* **2010**, *52* (4), 403–414.
- (55) Abdulla, A.; Azevedo, I. L.; Morgan, M. G. Expert Assessments of the Cost of Light Water Small Modular Reactors. *Proc. Natl. Acad. Sci.* **2013**, *110* (24), 9686–9691.
- (56) Duke Energy. *2017 Climate Report to Shareholders*; 2018.
- (57) Muratori, M. (2018). Impact of uncoordinated plug-in electric vehicle charging on residential power demand. *Nature Energy*, 3(3), 193. Data source available at: <https://catalog.data.gov/dataset/impact-of-uncoordinated-plug-in-electric-vehicle-charging-on-residential-power-demand-sup-31006>
- (58) National Renewable Energy Laboratory, System Advisor Model v2017.9.5. (2017).



- <https://sam.nrel.gov/>
- (59) North American Electric Reliability Corporation, Generating Availability Data System Report (2017)  
<https://www.nerc.com/pa/RAPA/gads/Pages/Reports.aspx>
  - (60) US Energy Information Administration. US Electric System Operating Data  
[https://www.eia.gov/realtime\\_grid/](https://www.eia.gov/realtime_grid/) (accessed June 28, 2018).

## 6. Datasets

### 6.1. Dataset A – Technologies

Table 12C. Technologies mapped from EIA Form 860 to this study.

Technology	Prime Mover <sup>a</sup>	Energy Source <sup>b</sup>	TEMOA Tech <sup>c</sup>	Existing Capacity (MW) <sup>d</sup>
All Other	ST	TDF	unknown	201
All Other	ST	WH	unknown	0
Conventional Hydroelectric	HY	WAT	EHYDCONR	2,934.30
Conventional Steam Coal	ST	BIT	ECOASTMR	11,694.80
Hydroelectric Pumped Storage	PS	WAT	EHYDREVR	2,802.00
Landfill Gas	FC	LFG	unknown	10
Landfill Gas	GT	LFG	ELFGGTR	36
Landfill Gas	IC	LFG	ELFGICER	78.4
Natural Gas Combined Cycle	CA	NG	ENGACCR	1,153.00
Natural Gas Combined Cycle	CT	NG	ENGACCR	4,117.80
Natural Gas Combustion Turbine	GT	NG	ENGACTR	11,104.30
Nuclear	ST	NUC	EURNALWR	11,693.80
Other Waste Biomass	ST	SLW	EBIOSTMR	0
Petroleum Liquids	GT	DFO	EDSLCTR	510
Petroleum Liquids	IC	DFO	EDSLCTR	216.7
Solar Photovoltaic	PV	SUN	ESOLPVR	2,901.40
Wood/Wood Waste Biomass	ST	WDS	EBIOSTMR	166
Wood/Wood Waste Biomass	ST	BLQ	EBIOSTMR	428.4

- Prime mover code from EIA Form 860: ST – Steam turbine, HY – Hydro turbine, PS – Energy storage, FC – Fuel cell, GT – Gas turbine, IC – Internal combustion engine, CA – Combined cycle steam part, CT – Combined cycle combustion turbine part, PV – Photovoltaic.
- Energy source code from EIA Form 860. Note that although two fuel sources are provided for some technologies, the technology in EIA Form 860 is mapped to Temoa technology only based on the type of prime mover and energy source 1. Energy source codes: TDF – Tire-derived fuels, WH – Waste heat, WAT – Water, BIT – Bituminous coal, LFG – Landfill gas, NG – Natural gas, NUC – Nuclear, SLW – Sludge waste, DFO – Distillated fuel oil (including diesel, No. 1, No. 2, and No. 4 fuel oils), SUN – Solar, WDS – Wood/Wood waste solid, BLQ – Black liquor.
- Technologies named “unknown” are excluded.
- Note that summer capacities from EIA Form 860 are used to calculate existing capacities following traditions in EIA State Electricity Profiles.

## 6.2. Dataset B – Commodities

Table 13C. List of commodities used in this study.

Commodity	Sector	Description
	p = physical e = emissions	
Ethos	p	Dummy commodity to supply inputs
COALSTMCC	p	Coal
COALIGCCCC	p	Coal
COALIGCC	p	Coal
COALSTM	p	Coal
ELCNGAEA	p	Natural Gas
ELCDSLEA	p	Diesel
LFGICEEA	p	Landfill gas to ICE
LFGGTREA	p	Landfill gas to gas turbines
URNA	p	Uranium
ELCBIGCEA	p	Biomass to IGCC
ELCBIOSTM	p	Biomass to steam
ELCGEO	p	Geothermal
SOL	p	Solar
WND	p	Wind
ELCHYD	p	Hydro
ELCRNWB	p	Electricity, physical, from renewables
ELC	p	Electricity, physical, to transmission
ELCDIS	p	Electricity, physical, to distribution
ELCDMD	d	Electricity, demand
co2	e	CO <sub>2</sub> emissions
so2_ELC	e	SO <sub>2</sub> emissions from the electric sector
nox_ELC	e	NO <sub>x</sub> emissions from the electric sector
so2_SUP	e	SO <sub>2</sub> emissions from the supply sector
nox_SUP	e	NO <sub>x</sub> emissions from the supply sector
COALSTM_R_B	p	Existing BIT coal steam to the blending tech
COAB_R	p	Existing BIT coal after SCR/SNCR or SCR PT to the bit blending technology for existing coal steam
COAB_R_SCR_PT	p	Existing bituminous coal after LNB retrofit or passthrough to the SCR SNCSR NO <sub>x</sub> retrofit or passthrough
COAB_R_LNB	p	Existing bituminous coal after CO <sub>2</sub> capture to the LNB retrofit
COAB_R_LNB_PT	p	Existing bituminous coal after SO <sub>2</sub> or CO <sub>2</sub> passthrough to the LNB nox retrofit or passthrough
COAB_R_CC	p	Existing bituminous coal after SO <sub>2</sub> removal to the CO <sub>2</sub> capture retrofit or passthrough

### 6.3. Dataset C – Costs

Table 14C. List of investment costs for the different generation technologies in \$/kW.

<b>Technology</b>	<b>2017</b>	<b>2020</b>	<b>2025</b>	<b>2030</b>
EBIOIGCC	3,963.0	3,920.0	3,806.0	3,733.0
ECOALIGCC	5,454.0	5,405.0	5,291.0	5,172.0
ECOALIGCCS	6,031.0	5,977.0	5,851.0	5,720.0
ECOALSTM	3,940.0	3,903.0	3,850.0	3,802.0
EGEOBCFS	5,115.0	5,076.0	5,012.0	4,948.0
ENGAACC	1,053.0	1,048.0	1,025.0	1,001.0
ENGAACT	899.0	896.0	874.0	852.0
ENGACC05	1,053.0	1,048.0	1,025.0	1,001.0
ENGACCCCS	2,193.0	2,168.0	2,079.0	1,991.0
ENGACT05	899.0	896.0	874.0	852.0
ESOLPVCEN	1,212.0	964.0	873.0	821.0
ESOLPVDIS	2,897.0	2,306.0	1,817.0	1,493.0
ESOLSTCEN	7,565.0	6,643.0	6,224.0	5,806.0
EURNALWR15	6,154.0	6,143.0	6,044.0	5,887.0
EWNDOFS	5,241.0	4,955.0	4,329.0	3,671.0
EWNDON	1,571.0	1,534.0	1,482.0	1,442.0
E_LNBSCR_COAB_N	1.535	1.535	1.535	1.535
E_LNBSNCR_COAB_N	0.786	0.786	0.786	0.786
E_SNCR_COAB_N	0.544	0.544	0.544	0.544
E_SCR_COAB_N	1.284	1.284	1.284	1.284
E_LNB_COAB_N	0.252	0.252	0.252	0.252
E_CCR_COAB	15.11	15.11	15.11	15.11
E_FGD_COABH_N	3.184	3.184	3.184	3.184
E_FGD_COABM_N	2.347	2.347	2.347	2.347
E_FGD_COABL_N	3.797	3.797	3.797	3.797
E_CCR_COALIGCC_N	14.52	14.52	14.52	14.52
E_CCR_COALSTM_N	20	20	20	20

Table 15C. List of fixed O&M costs for all technologies except future wind and solar in \$/kWyr.

Technology	Vintage	2017	2020	2025	2030
EBIOIGCC	ALL	112	112	112	112
EBIOSTMR	ALL	12.5	12.5	12.5	12.5
ECOALIGCC	ALL	54.5	54.5	54.5	54.5
ECOALIGCCS	ALL	79.4	79.4	79.4	79.4
ECOALSTM	ALL	33	33	33	33
ECOASTMR	ALL	33	33	33	33
EDSLCTR	ALL	5.8	5.8	5.8	5.8
EGEOBCFS	ALL	119.7	119.7	119.7	119.7
EHYDCONR	ALL	9.7	9.7	9.7	9.7
EHYDREVR	ALL	14.4	14.4	14.4	14.4
ELFGGTR	ALL	159.2	159.2	159.2	159.2
ELFGICER	ALL	197.5	197.5	197.5	197.5
ELFGICER	ALL	197.5	197.5	197.5	197.5
ENGAACC	ALL	16.3	16.3	16.3	16.3
ENGAACT	ALL	7.5	7.5	7.5	7.5
ENGACC05	ALL	14	14	14	14
ENGACCCCS	ALL	34.7	34.7	34.7	34.7
ENGACCR	ALL	4.6	4.6	4.6	4.6
ENGACT05	ALL	7.8	7.8	7.8	7.8
ENGACTR	ALL	5.8	5.8	5.8	5.8
ESOLPVR	ALL	20	20	20	20
ESOLSTCEN	ALL	63	63	63	63
EURNALWR	ALL	83.4	83.4	83.4	83.4
EURNALWR15	ALL	98.9	98.9	98.9	98.9
EURNSMR	ALL	118.7	118.7	118.7	118.7
ESLION	ALL	10.0	10.0	10.0	10.0
ESZINC	ALL	32.0	29.0	28.0	26.0
ESCAIR	ALL	32.0	30.0	29.0	27.0
ESFLOW	ALL	24.0	17.0	11.0	10.0
E_CCR_COAB	ALL	0.264	0.264	0.264	0.264
E_CCR_COALIGCC_N	ALL	0.435	0.435	0.435	0.435
E_CCR_COALSTM_N	ALL	0.346	0.346	0.346	0.346
E_LNBSCR_COAB	ALL	0.009	0.009	0.009	0.009
E_LNB SNCR_COAB	ALL	0.008	0.008	0.008	0.008
E_SCR_COAB_N	ALL	0.009	0.009	0.009	0.009
E_SNCR_COAB	ALL	0.008	0.008	0.008	0.008

Table 16C. List of fixed costs for future onshore wind and solar PV in \$/kW-yr.

<b>Technology</b>	<b>2017</b>	<b>2020</b>	<b>2025</b>	<b>2030</b>
ESOLPVCEN	19.4	19.4	19.4	19.4
ESOLPVDIS	0.0	0.0	0.0	0.0
EWNDON	23.5	23.5	22.5	21.4

Table 17C. List of input commodities' variable costs in operational model, M\$/PJ, or \$/GJ.

<b>Commodity</b>	<b>Variable Cost</b>
IMPELCCOAB	2.65
IMPELCNGAEA	4.77
IMPELCNSLEA	20.09
IMPURNA	2.809
IMPELCBIGCCEA	3.39
IMPELCBIOSTM	3.39
IMPELCGEO	0.0
IMPSOL	0.0
IMPWND	0.0
IMPELCHYD	0.0
IMPLFGICEEA	0.0
IMPLFGGTREA	0.0

Table 18C. List of variable costs for all technologies in this study, M\$/PJ, or \$/GJ.

Technology	Vintage	Period							
		2015	2020	2025	2030	2035	2040	2045	2050
EBIOIGCC	ALL	1.549	1.549	1.549	1.549	1.549	1.549	1.549	1.549
EBIOSTMR	ALL	5.909	5.909	5.909	5.909	5.909	5.909	5.909	5.909
ECOALIGCC	ALL	2.126	2.126	2.126	2.126	2.126	2.126	2.126	2.126
ECOALIGCCS	ALL	2.559	2.559	2.559	2.559	2.559	2.559	2.559	2.559
ECOALSTM	ALL	1.316	1.316	1.316	1.316	1.316	1.316	1.316	1.316
ECOASTMR	ALL	1.316	1.316	1.316	1.316	1.316	1.316	1.316	1.316
EDSLCTR	ALL	10.233	10.233	10.233	10.233	10.233	10.233	10.233	10.233
EGEOBCFS	ALL	0	0	0	0	0	0	0	0
EHYDCONR	ALL	5.244	5.244	5.244	5.244	5.244	5.244	5.244	5.244
EHYDREVR	ALL	6.124	6.124	6.124	6.124	6.124	6.124	6.124	6.124
ELFGGTR	ALL	0	0	0	0	0	0	0	0
ELFGICER	ALL	0	0	0	0	0	0	0	0
ENGAACC	ALL	0.963	0.963	0.963	0.963	0.963	0.963	0.963	0.963
ENGAACT	ALL	3.053	3.053	3.053	3.053	3.053	3.053	3.053	3.053
ENGACC05	ALL	1.06	1.06	1.06	1.06	1.06	1.06	1.06	1.06
ENGACCCCS	ALL	2.053	2.053	2.053	2.053	2.053	2.053	2.053	2.053
ENGACCR	ALL	1.426	1.426	1.426	1.426	1.426	1.426	1.426	1.426
ENGACT05	ALL	4.549	4.549	4.549	4.549	4.549	4.549	4.549	4.549
ENGACTR	ALL	9.314	9.314	9.314	9.314	9.314	9.314	9.314	9.314
ESOLPVCEN	ALL	0	0	0	0	0	0	0	0
ESOLPVDIS	ALL	0	0	0	0	0	0	0	0
ESOLPVR	ALL	0	0	0	0	0	0	0	0
ESOLSTCEN	ALL	0	0	0	0	0	0	0	0
EURNALWR	ALL	0.459	0.459	0.459	0.459	0.459	0.459	0.459	0.459
EURNALWR15	ALL	0.63	0.63	0.63	0.63	0.63	0.63	0.63	0.63
EURNMSMR	ALL	0.756	0.756	0.756	0.756	0.756	0.756	0.756	0.756
EWNDOFS	ALL	0	0	0	0	0	0	0	0
EWNDON	ALL	0	0	0	0	0	0	0	0
ESLION	ALL	0.041	0.041	0.041	0.041	0.041	0.041	0.041	0.041
EE	ALL	1.62	1.42	1.77	2.16	2.59	3.13	3.6	4.15
EDISTR	ALL	6.407	7.018	7.188	7.348	7.585	7.781	8	8.1
ETRANS	ALL	1.935	2.389	2.547	2.735	2.953	3.121	3.235	3.28

Table 19C. List of efficiencies for all technologies in this study.

Technology	Vintage	Efficiency	Unit
EBIOIGCC	2017-2050	0.253	Dimensionless
EBIOSTMR	1975-2010	0.219	Dimensionless
ECOALIGCC	2017	0.392	Dimensionless
ECOALIGCC	2020	0.423	Dimensionless
ECOALIGCC	2025-2050	0.458	Dimensionless
ECOALIGCCS	2017-2050	0.411	Dimensionless
ECOALIGCCS_b	2017-2050	0.411	Dimensionless
ECOALIGCC_b	2017	0.392	Dimensionless
ECOALIGCC_b	2020	0.423	Dimensionless
ECOALIGCC_b	2025-2050	0.458	Dimensionless
ECOALSTM	2017-2050	0.388	Dimensionless
ECOALSTM_b	2017-2050	0.388	Dimensionless
ECOASTMR	1960-2010	0.352	Dimensionless
ECOASTMR_b	1960-2010	0.352	Dimensionless
EDSLCTR	1975-2010	0.224	Dimensionless
ELFGGTR	1995-2010	0.3	Dimensionless
ELFGICER	2000-2010	0.36	Dimensionless
ENGAACC	2017	0.531	Dimensionless
ENGAACC	2020	0.535	Dimensionless
ENGAACC	2025-2050	0.539	Dimensionless
ENGAACT	2017	0.35	Dimensionless
ENGAACT	2020	0.373	Dimensionless
ENGAACT	2025-2050	0.399	Dimensionless
ENGACC05	2017	0.484	Dimensionless
ENGACC05	2020	0.493	Dimensionless
ENGACC05	2025-2050	0.502	Dimensionless
ENGACCCCS	2017-2050	0.455	Dimensionless
ENGACCR	1990-2010	0.474	Dimensionless
ENGACT05	2017	0.313	Dimensionless
ENGACT05	2020	0.345	Dimensionless
ENGACT05	2025-2050	0.385	Dimensionless
ENGACTR	1990-2010	0.248	Dimensionless
EURNALWR	1975-1985	1.268 <sup>a, b</sup>	PJe/tonneIHM
EURNALWR15	2017-2050	1.268	PJe/tonneIHM
EURNMR	2017-2050	1.693 <sup>c</sup>	PJe/tonneIHM
E_CCR_COAB	2017-2050	0.65	Dimensionless
E_CCR_COALIGCC_N	2017-2050	0.8	Dimensionless
E_CCR_COALSTM_N	2017-2050	0.7	Dimensionless

a. This efficiency represents the product of burn-up rate  $\times$  thermal efficiency. Burnup is the amount of thermal heat production per tonne of 'IHM', which is initial heavy metal and refers to the enriched uranium used in the reactor core.

b. Burnup rate: 45 GWd/tonneIHM, thermal efficiency: 32.6%.

c. Burnup rate: 70 GWd/tonneIHM, thermal efficiency: 28%.



## Appendix D. Stakeholder comments received on specific elements from Section 9: Identification of Barriers and Policy Options

**Table D.1.** Comments on the potential policies or programs with the greatest ability to influence energy storage in North Carolina as received through an anonymous, self-selected survey made available to the study stakeholder group. The exact text of comments has been preserved here, though some formatting revisions have been made to minimize space.

This section in the Duke Energy Service Regulations makes it impossible for a large corporation to effectively install EV charging stations. Duke's response is to "rent" the space, this creates a logistical nite mare to manage. What is being ask is no different than the exception granted landlord for the resale of electricity via the user and the owner of the EV charging station: "Resale Service This contract is made and electricity is sold and delivered upon the express condition that electricity supplied by the Company shall be for the Customer's use only and the Customer shall not directly or indirectly sell or resell, assign, or otherwise dispose of the electricity or any part thereof, on a metered or unmetered basis to any person, firm or corporation except, (1) as provided for in G.S. 62-110(h) regarding resale of electricity by landlords to residential tenants where the landlord has a separate lease for each bedroom in the unit, and where such landlord has complied with the requirements in Chapter 22 of the Rules and Regulations of the Commission, or (2) as may be exempt from regulation under G.S. 62-3(23)(d) and (h). Under no circumstances will the Company supply electricity for resale in competition with the Company."

Mandating that utilities consider non-wire alternative solutions (NWS) on equal footing to conventional wire solutions, whenever the need arises for grid upgrades due to capacity or reliability reasons.

(1) NC Interconnection procedures will define how storage IX requests are studied and whether storage additions are "material modification", (2) Integrated resource planning could set the "roadmap" for storage deployment, (3) the modeling that supports the IRP process must properly account for the value streams storage can provide, (4) the current storage provisions filed by Duke for the CPRE are overly restrictive

**NON-STORAGE SPECIFIC:** Increasing penetration of variable/non-dispatchable wind/solar; Increasing penetration of DERs; More stringent local ambient air quality regulations. **STORAGE SPECIFIC:** Policies that increase grid access (reforms to interconnection processes for storage; framework for multiple-use storage [end-user / Dx / Tx]; reforms to procurement processes; regulatory reforms that enable hybrid business models; removal of classification barriers for all stakeholders to own storage); Policies that increase competition (inclusion and appropriate modeling in IRPs; inclusion in Distribution Resource Planning; use of all-source RFPs and/or a non-wires alternatives framework; inclusion in transmission planning; eligibility/credit in existing programs [DR, PURPA, RPS, etc]; eligibility to participate in wholesale markets); Policies that enable valuation (incentive programs [rebate, tax credit, etc]; deployment targets or mandates; use of state financing authorities to lever cheaper/more private capital; programs to value time of delivery of energy [clean peak std, etc]; reformed rate designs that value time of delivery, demand management).

The IREC and ESA reports on state policy for energy storage (already included in your lit review, but reflagged here) all both strong resources identify and detailing the specific approaches states have taken and should take with storage. To influence adoption, the models suggest making storage a part of renewable energy procurements, developing direct incentive programs (e.g. SGIP in CA and ACES in MA), embedding energy storage within integrated resource planning, and develop time varying rates that incentivize storage ownership and operation. Some specific initial policy actions the reports recommend for states are to clarify interconnection standards and ownership models, require fair consideration and valuation of storage in utility planning, and create mechanisms for full value capture. On the emissions side, another piece to consider is the SGIP Working Group Report on GHG emissions. [<http://energystorage.org/statepolicymenu>; <https://irecusa.org/2017/04/irec-releases-energy-storage-guide-for-policy-makers/>; <http://www.cpuc.ca.gov/WorkArea/DownloadAsset.aspx?id=6442457832>].

I am not an engineer but it seems to me the two highest value propositions for energy storage in the near-term are (1) discharging dispatchable batteries/storage to "clip the peak" and avoid or reduce demand charges and (2) using batteries as flexload capable of soaking up operationally excess energy. As to the flexload value proposition, increasing the numbers of electric vehicles on the grid may enable systemic load shifting of charging into the periods of the day when solar is producing and help soak up what would otherwise be operationally excess energy and help "clean and green" the electricity driving these vehicles. If experts agree with these premises, why wouldn't we consider/promote a state-level incentive to drive electric vehicle adoption which would promote (1) capture of this flexload value AND (2) drive cost reduction in lithium ion battery technology via economies of scope/scale, which in turn will drive down the cost of EVs and stationary dispatchable batteries?

**NC General Assembly:** HB589 banned third-party power-purchase agreements for solar (and other generation), repealing that would help storage deployment; it would help if the NCGA passed PACE legislation for financing storage and solar on property tax bills (was introduced 2017 as SB493; hopefully will come up again in 2019); it would help if NCGA repealed caps and expiration dates on solar programs established by HB589; it would help if NCGA enacted more robust community solar legislation than that provided in HB589; strategically-sited community solar systems paired with storage could be of significant value to the grid; such legislation should allow community ownership (not just utility ownership) and require low-income accessibility and guaranteed savings for participants.

**NC Utilities Commission:** it would help if NCUC held evidentiary hearings on Duke Energy's Integrated Resource Plan so that expert witnesses could argue the value of renewables and storage over continued coal generation and increased gas generation; should require more explicit proof from Duke Energy that the company is proposing lowest-cost generation (some states have already rejected gas plant applications as more costly than solar+storage; that day is not far away in NC); should require more explicit proof from Duke Energy of its demand projections; experts have argued that Duke maintains excess generation capacity that far exceeds legal and regulatory standards.

**Duke Energy:** should be required to offer on-bill financing of solar, storage and energy efficiency upgrades.

**Governor/DEQ:** should reverse decision on approval of Atlantic Coast Pipeline permits; increased use of natural gas will only slow the deployment of storage; pipelines will become stranded assets and customer rates should be used instead to pay for storage

---

**Table D.2.** Comments received on the September 27, 2018 draft write-up of the section entitled “Energy Storage Policy and Regulatory Context in North Carolina” through an anonymous, self-selected survey made available to the study stakeholder group. The exact text of comments has been preserved here.

---

I'm am not certain that this is helpful, but I see this as an opportunity for an optimization study of cost shifting or balancing of utility, commercial and residential (suppliers) overlaid on the topography (demand) of the state indicating where installations should be placed, how much and and by which of the aforementioned three market suppliers.

The categories are appropriate, but the report section is missing analysis that synthesizes the findings from all these categories and depicts the current state of the policy landscape for storage in the state in a comprehensive manner, even at a high level. e.g., uncertainty about definitional issues (is storage included in REPS target, is storage a utility, is adding storage a major modification, does adding storage to a solar farm exceed PURPA limits based on nameplate capacity, etc.), virtually no storage-specific business models, rates, few programs to promote storage outside of demonstration projects. I'd also like to see the report explicitly acknowledge the categories of policies and programs that are available in other states but absent in NC, whether in this section or another. The report also glosses over the myriad local level policies that are not storage-specific, but have an impact nonetheless, such as permitting ordinances, tax incentives, etc.

The draft makes mention of ancillary services markets in PJM, but should also state that similar markets are not currently availalbe for storage in NC. This is significant because battery storage (and its related inverters) can provide ancillary services which are lower cost and faster responding than similar services from conventional static compensators or rotating generation equipment.

---

## Appendix E: Description of Policy Categories and individual Policy Types used to classify policies in the review of existing state initiatives on energy storage.

<b>Analysis, R&amp;D, &amp; Market Support:</b> Efforts to support research, technical development, and storage deployment, ranging from studies to technology development to training programs.	
Research Support	Includes R&D and direct technical assistance for the purposes of tech development and deployment
Energy Storage Study	An analysis of the technical and/or economic potential of storage with a goal of informing policy.
<b>Planning &amp; Access:</b> Efforts to define, reform, or refine utility planning processes and/or the rules affecting access to everything from data to state or wholesale markets.	
Integrated Resource Planning	Focuses on aspect of reforming, removing, or creating requirements within the IRP process.
Roadmap Development	A discrete planning process to identify policy, technology, and/or market needs to develop and deploy storage, as well as the processes by which to address those needs.
Clean Peak Standard/RPS	Focuses on aspects of incorporating energy storage into Clean Peak and Renewable Energy goals
Moratorium/ Cap on Procurement	Caps utility procurement from non-renewable sources of electricity generation
Wholesale Market Rules	Focuses on aspects of the bidding process(es) and market-based mechanisms for incorporating energy storage.
Open-Access Grid Data	Focuses on aspects of requiring electric grid data to be shared.
Grid Modernization Planning	Focused on aspects of requirements for updating electricity grids including defining suitable energy storage applications within grid.
Load Management Plan	Focuses on energy storage consideration for load management
Non-Wires Alternatives	Focuses on grid options to reduce and prevent further wires deployment for transmission of electricity
<b>Business Model &amp; Rate Reform:</b> Efforts to change how utilities are regulated or operate under a particular state or wholesale market. Can also consist of more targeted changes to rate design (e.g., time-of-use rates, demand charges).	
Rate Design	Focuses appropriate costs of service, payment programs and/or exemptions in rate payments.
Utility Business Model Reform	Focuses on Utility requirements regarding generation assets, performance-based metrics tied to utility revenues, and deregulation/restructuring efforts.
Time-Varying Rates	Focuses on details of piloting or requiring utilities to offer TOU rate option.
Fixed Charges	Focuses on requirements regarding design and magnitude of fixed-charges to customers.

**Mandates:** Policies establishing minimum deployment targets or performance standards.

Clean Peak Standard	Focuses on requirement for percentage of energy used to meet peak load hours to be derived from clean sources.
Energy Storage Target	Focuses on proposed or currently mandated energy storage targets in MWs. In addition, some specify which technologies can be considered in meeting storage target. Can also refer to soft targets or goals.
RPS	Focuses on aspects of reforming, renaming, and Renewable Energy goals to better accommodate and incorporate newer technologies like energy storage.
Self-Directed Program	Required Commission to promote renewables and energy storage technologies.
Energy Storage Substation Mandate	Focuses on a more specific energy storage of number of substations or feeders featuring energy storage.

**Process & Approvals:** Policies that govern the regulatory process for the deployment of storage (e.g., interconnection standards, compensation rules).

Interconnection	Focuses on aspects of developing, recommending, reforming and exempting issues within interconnection rules/standards.
Energy Storage Compensation	Similar to rate design policy type - focuses on energy storage and DG eligibility under different compensation mechanism and reforming of metering rules.
Permitting Process	Focuses on streamlining the permit process, reducing the burden and costs to residential customers, and/or restrictions on receiving a permit for energy storage.
Procurement Authority	Focuses on establishing organizational/agency authority to set and energy storage target.
Energy Storage Cost Recovery	Focuses specifically on timeline of utility cost recovery.
Distributed Energy Resources	Focuses on utility guidelines for DER, including what technologies constitute DER.
Energy Storage Ownership	Focuses on definitions and details for utility ownership of energy storage assets.
Safety and Building Code Requirements	Focuses on building requirements and proposed energy storage specific safety regulations.
Microgrid Rules	Focuses on rules specific to energy storage role in microgrids.
Defining Storage Services	Focuses on defining eligibility of energy storage for services.
Wholesale Pricing	Focuses on rules governing price mechanisms for whole energy storage.

**Incentives & Financing:** Policies that provide funding to, defray the cost of, or provide an increased benefit for, the deployment of storage.

On-Bill Financing	Focuses on program in which the utility incurs the cost of the clean energy upgrade, specific to energy storage, but is then repaid by customer on the utility bill
-------------------	---

Rebate Program	Focuses on establishing or increasing funds for rebate programs eligible to energy storage technologies.
Low-Income Incentive Program	Focuses on establishing or increasing funds programs providing funding to incentivize energy storage for low-income customers and communities.
Grant Program	Focuses on establishing or increasing funds for programs offering grants eligible to energy storage technologies.
Tax Credit	Focuses on the creation or expansion of tax credits for installing energy storage systems.
Performance-Based Incentive	Focuses on establishing energy storage incentive programs based on performance metrics.
Tax Exemption	Focuses on establishing tax exemption for energy storage systems under state tax code.
Developer Incentive	Focuses on initiatives to decrease barriers for energy storage businesses to establish business in state.
Financing Program	Focuses on establishing finance programs and/or defining energy storage systems for eligibility
Solar + Storage Incentive	Focuses on establishing financials added if solar is paired with energy storage
<b>Utility-Driven Demonstrations:</b> Utility-led programs to purchase, fund, or deploy of storage. Note that the emphasis here is on programs for deployment, not individual installations themselves.	
Energy Storage & Procurement Plan	Focuses on utility-scale energy storage purchase or deployment.
Energy Storage Proposals	Focuses on utility proposals/plans for energy storage, including states requiring utilities to submit proposals.
Grid Modernization	Focuses on proposing and implementing grid modernization projects.

# Appendix F: Compilation of state policies related to energy storage

Policy Category (Primary)	Policy Type (Primary)	Policy Category (Secondary)	Policy Type (Secondary)	Description	State	Vertically-Integrated (yes= x) <sup>1</sup>	Southeast Region (yes= x) <sup>2</sup>	Duke in State (yes= x)	Dominion in State (yes= x)	TVA in State (yes= x)	PJM in State (yes=x)	IRP (yes= x) <sup>3</sup>	%Renewables <sup>4</sup>	%Gas <sup>4</sup>	%Nuclear <sup>4</sup>	Policy Source
Process & Approvals	Interconnection			North Carolina adopted revised interconnection standards in 2015. Subsequent working groups convened to review how the revised standards are functioning are assessed, among other elements, the role of new technologies like energy storage. A December 2017 report submitted by the Public Staff indicated that consensus on necessary revisions to the standard could not be reached, but there was nonetheless agreement that the resulting standards should apply to energy storage.	NC	x	x	x	x	x	x	x	16.6	33.1	15.8	NCCETC (2018)
Utility-Driven Demonstrations	Grid Modernization			Investor-owned utilities were required to submit Smart Grid Technology Plans as part of their Biennial IRP and Renewable Energy Portfolio Standard Compliance proceeding. Submitted plans included a variety of smart grid technologies and applications including AMI and microgrid projects. Submitted plans were subsequently approved by the North Carolina Utilities Commission, but the Commission also requested that discussions around customer data access continue.	NC	x	x	x	x	x	x	x	16.6	33.1	15.8	NCCETC (2018)
Analysis, R&D, & Market Support	Energy Storage Study			H.B. 589 directed the North Carolina Policy Collaboratory to study how energy storage technologies may or may not provide value to North Carolina consumers. The study was to address the feasibility of storage in the state, the economic potential or impact of storage deployment, and recommended policy changes that may be considered.	NC	x	x	x	x	x	x	x	16.6	33.1	15.8	<a href="https://www2.ncleg.net/BillLookup/2017/h589">https://www2.ncleg.net/BillLookup/2017/h589</a>
Process & Approvals	Energy Storage Compensation			In July 2017, Duke Energy Indiana submitted a petition for approval of a new tariff (for small commercial and residential customers) that would be applied to customers opting out of AMI equipment installation. The tariff would not be available for customers using TOU rates or participating in net metering, and customers would not be eligible to participate in any new services that require the use of smart meters. A hearing on a subsequent settlement agreement related to the petition was held in March 2018.	IN	x		x	x		x	x	9.1	25.3	0	NCCETC (2018)
Process & Approvals	Energy Storage Cost Recovery			In 2017, Duke Energy Indiana sought approval to recover costs for Camp Atterbury Microgrid and Nabb Battery through standard renewable energy rider (Rider 73). The request was approved in May of 2018.	IN	x		x	x		x	x	9.1	25.3	0	<a href="https://www.in.gov/urc/files/45002_ord_20180530143447762.pdf">https://www.in.gov/urc/files/45002_ord_20180530143447762.pdf</a>
Utility-Driven Demonstrations	Energy Storage Proposals	Utility-Driven Demonstrations	Grid Modernization	In October 2017, Duke Energy Indiana submitted a proposal for two projects: one is a combined solar and battery storage facility connected to a microgrid, and the other is a standalone battery storage facility. A hearing on the matter was scheduled for April 2018.	IN	x		x	x		x	x	9.1	25.3	0	NCCETC (2018)
Incentives & Financing	Tax Credit			H.B. 1018, introduced in January 2018, would create a tax credit for energy storage projects of 30%, up to \$5,000 for residential projects and \$75,000 for commercial projects. The bill died in Committee in February.	VA	x			x	x	x	x	19.2	44.3	13.4	NCCETC (2018); <a href="https://is.virginia.gov/cgi-bin/legp604.exe?181+sum+HB1018">https://is.virginia.gov/cgi-bin/legp604.exe?181+sum+HB1018</a>
Planning & Access	Grid Modernization Planning			S.B. 966, enacted in March 2018, declares that distribution grid transformation projects are in the public interest, and provides for a process for utilities to request cost recovery from the State Corporation Commission. The legislation's definition of grid transformation projects includes advanced metering infrastructure, intelligent grid devices, automated control systems for electric distribution circuits and substations, communications networks for service meters, certain distribution system hardening projects (excluding undergrounding), physical security measures at key distribution substations, cyber security measures, certain energy storage systems and microgrids, electrical facilities and infrastructure for electric vehicle charging systems, LED street light conversions, and new customer information platforms.	VA	x			x	x	x	x	19.2	44.3	13.4	NCCETC (2018); <a href="http://is.virginia.gov/cgi-bin/legp604.exe?181+sum+SB966">http://is.virginia.gov/cgi-bin/legp604.exe?181+sum+SB966</a>
Analysis, R&D, & Market Support	Energy Storage Study			H.B. 5002, the 2018 Budget Bill, directs the Virginia Solar Development Authority and Department of Mines, Minerals, and Energy to conduct a study to determine whether or not legislation adopting regulatory reforms and incentives will be helpful in encouraging emerging energy storage capacity in the state. The report is due in September 2019.	VA	x		x	x	x	x	x	19.2	44.3	13.4	<a href="https://is.virginia.gov/cgi-bin/legp604.exe?182+sur">https://is.virginia.gov/cgi-bin/legp604.exe?182+sur</a>
Utility-Driven Demonstrations	Energy Storage Proposals			S.B. 966 also directs the State Corporation Commission to establish pilot programs for the deployment of battery storage. Utility proposals to deploy storage through this program should either improve distribution or transmission system reliability; improve renewables integration; defer investments in generation, transmission, or distribution; reduce the need for additional generation during peak periods, or connect to the facilities of a customer receiving service from the utility. Appalachian Power may deploy up to 10 MW of capacity, while Dominion may deploy up to 30 MW of capacity. The pilot program is to last five years, and utilities may recover costs through their base rates. The Commission is to establish program rules by December 1, 2018.	VA	x			x	x	x	x	19.2	44.3	13.4	NCCETC (2018)
Process & Approvals	Interconnection			In December 2017, Tampa Electric Company filed a petition for approval of a standard interconnection agreement for grid-connected, customer-owned battery storage systems. In February 2018, the Public Service Commission approved the standard interconnection agreement.	FL	x	x	x				x	3.4	65	6.1	NCCETC (2018)
Utility-Driven Demonstrations	Energy Storage Proposals			A proposed August 2017 settlement agreement primarily related to Duke Energy Florida's Levy Nuclear Plant also proposes the deployment of a 50 MW battery storage pilot program. Duke Energy Florida will determine the projects and locations offering the greatest benefits, and the cost of the projects is not to exceed \$2,300 per kW. The settlement does not preclude parties from challenging the reasonableness of the costs incurred for the program.	FL	x	x	x				x	3.4	65	6.1	NCCETC (2017); <a href="https://www.greentechmedia.com/articles/read/duke-e-energy-plans-eb-for-solar-batteries-and-evs#gs.MaadVPU">https://www.greentechmedia.com/articles/read/duke-e-energy-plans-eb-for-solar-batteries-and-evs#gs.MaadVPU</a>
Utility-Driven Demonstrations	Energy Storage Proposals			The Electric Security Plan filed by Duke Energy Ohio in June 2017 included a 10 MW pilot battery storage system.	OH			x	x		x	x	3.1	33.5	7.4	NCCETC (2018)
Incentives & Financing	Financing Program			S.B. 261 would create a commercial PACE financing program under which storage systems (battery and thermal) would be eligible.	SC	x	x	x				x	20.4	25.3	29	NCCETC (2018)
Incentives & Financing	Tax Exemption			S.B. 44 would set a property tax exemption (80%) for DERs, including energy storage.	SC	x	x	x				x	20.4	25.3	29	NCCETC (2018)
Planning & Access	Integrated Resource Planning			H.B. 4425, introduced in January 2018, would overhaul the IRP process, placing increased emphasis on demand-side management resources, including distributed generation.	SC	x	x	x				x	20.4	25.3	29	NCCETC (2018); <a href="https://e.giscan.com/SC/bill/H4425/2017">https://e.giscan.com/SC/bill/H4425/2017</a>
Planning & Access	Grid Modernization Planning			S.B. 564 requires utilities deferring depreciation expenses and returns to file five-year capital investment plans and a specific capital investment plan for the following year. At least 25% of the costs of each year's plan must be from grid modernization projects.	MO	x	x					x	8.8	26.4	5.5	NCCETC (2018); <a href="https://senate.mo.gov/18info/BTS_Web/Bill.aspx?SessionType=R&amp;BillID=69471981">https://senate.mo.gov/18info/BTS_Web/Bill.aspx?SessionType=R&amp;BillID=69471981</a>
Planning & Access	Integrated Resource Planning			In 2015, the Missouri Public Service Commission required the utility KCP&L to include in their IRP an evaluation of energy storage resources.	MO	x	x					x	8.8	26.4	5.5	IREC (2017)

Process & Approvals	Microgrid Rules	Utility-Driven Demonstrations	Energy Storage Proposals	H.B 1412 allows distribution companies to propose energy storage and microgrid pilot programs, while also specifying that subsequent rulemakings shall not require utilities to own, develop, or deploy energy storage or microgrids.	PA		x	x	x	10.3	34.5	22.2	NCCETC (2018)
Business Model & Rate Reform	Rate Design			Arizona Corporation Commission ordered Arizona Public Service (APS) utility to develop \$6 million residential demand response/load management program to facilitate storage for residential customers. APS proposed "reverse demand response" program to pay storage to charge at periods of electricity oversupply. See, e.g., Docket no. E-01345A-17-0134.	AZ	x			x	18	47.6	13.8	K&L Gates (2018); <a href="http://www.klgates.com/ePubs/Energy-Storage-Handbook-October2017/">http://www.klgates.com/ePubs/Energy-Storage-Handbook-October2017/</a> ;
Business Model & Rate Reform	Rate Design	Planning & Access	Integrated Resource Planning	2017 Arizona Public Service Company rate case resulted in the creation of multiple storage-related provisions, for example the institution of an optional storage-specific rate for C&I customers and the requirement that the utility do a CBA of storage and compare to traditional resources.	AZ				x	18	47.6	13.8	<a href="https://www.azcc.gov/Divisions/Administration/new-s/2017Releases/2017-8-16%20Commission%20Approves%20APS%20Rate%20Application.asp">https://www.azcc.gov/Divisions/Administration/new-s/2017Releases/2017-8-16 Commission Approves APS Rate Application.asp</a> ; See also <a href="https://www.aps.com/library/rates/E-32%20L%20Storage%20Plot%20-%20Rev%2000.1%20-%202017-12-15.pdf">https://www.aps.com/library/rates/E-32%20L%20Storage%20Plot%20-%20Rev%2000.1%20-%202017-12-15.pdf</a> .
Incentives & Financing	Grant Program	Utility-Driven Demonstrations	Energy Storage Proposals	The Tucson Electric Power Company was ordered to develop a \$1.3 million load management/DR program in February 2017 by the Arizona Corporation Commission.	AZ	x			x	18	47.6	13.8	K&L Gates (2018); <a href="http://www.klgates.com/ePubs/Energy-Storage-Handbook-October2017/">http://www.klgates.com/ePubs/Energy-Storage-Handbook-October2017/</a>
Mandates	Clean Peak Standard	Mandates	Energy Storage Target	A docket was opened in August 2016 to review and modernize the state's renewable energy standard. In November 2016, a proposal was filed to create a Clean Peak Standard, requiring that a portion of peak load be met with clean energy. Other subsequent proposals included also included a 3GW by 2030 energy storage target and a requirement that 80% by 2050 clean portfolio standard.	AZ	x			x	18	47.6	13.8	NCCETC (2018); <a href="http://docket.images.azcc.gov/0000175087.pdf">http://docket.images.azcc.gov/0000175087.pdf</a>
Planning & Access	Clean Peak Standard/RPS			Arizona Corporate Commission proposed changes to the Renewable Energy Standard and Tariff (REST) rules in August of 2016, increasing the state renewable portfolio standard to 30% by 2030 and considering other revisions that would also incorporate storage.	AZ	x			x	18	47.6	13.8	K&L Gates (2018); <a href="http://www.klgates.com/ePubs/Energy-Storage-Handbook-October2017/">http://www.klgates.com/ePubs/Energy-Storage-Handbook-October2017/</a>
Planning & Access	Moratorium/Cap on Procurement			In 2018, the Arizona Corporation Commission placed a moratorium on utility procurement of capacity, barring them from large (>150MW) gas units and instead directing them to undertake an independent analysis of energy storage systems.	AZ	x			x	18	47.6	13.8	K&L Gates (2019); <a href="https://www.utilitydive.com/news/arizona-regulators-wants-to-adopt-80-clean-energy-plan-before-gas-moratorium/539019/">https://www.utilitydive.com/news/arizona-regulators-wants-to-adopt-80-clean-energy-plan-before-gas-moratorium/539019/</a>
Process & Approvals	Interconnection			In September 2017, Arizona Corporation Commission staff published draft statewide interconnection rules featuring new requirements for energy storage systems and advanced inverters.	AZ	x			x	18	47.6	13.8	NCCETC (2018)
Planning & Access	Integrated Resource Planning	Planning & Access	Grid Modernization Planning	In March 2018, Colorado lawmakers introduced HB 18-1270, requiring the Public Utilities Commission to establish rules for the procurement of energy storage by investor-owned utilities. The rules would need to consider factors such as grid reliability and reduction of peak demand.	CO	x			x	29.4	38.2	0	NCCETC (2018) , <a href="https://www.utilitydive.com/news/colorado-integrates-storage-into-utility-planning-process/524939/">https://www.utilitydive.com/news/colorado-integrates-storage-into-utility-planning-process/524939/</a>
Process & Approvals	Energy Storage Compensation			The Colorado Public Utilities Commission opened a proceeding in October 2017 to consider changes to rules concerning the Renewable Energy Standard, as well as net metering, electric resource planning, and acquisitions from qualifying facilities, and distribution system planning. One question the Commission noted it is particularly interested in is the eligibility of net metering for solar systems paired with storage. A scoping workshop was held in early April 2018 to create working groups to address the various issues under consideration.	CO	x			x	29.4	38.2	0	NCCETC (2018), <a href="http://programs.dsireusa.org/system/program/detail/133">http://programs.dsireusa.org/system/program/detail/133</a>
Process & Approvals	Energy Storage Cost Recovery			The Colorado Public Utilities Commission ICT (Innovative Clean Technology) program allows for <i>ex post</i> cost recovery for small demonstration-scale projects.	CO	x			x	29.4	38.2	0	<a href="https://www.colorado.gov/pacific/dora/news/puc-approves-xcel-energy-request-two-clean-technology-demonstration-projects">https://www.colorado.gov/pacific/dora/news/puc-approves-xcel-energy-request-two-clean-technology-demonstration-projects</a>
Process & Approvals	Interconnection			In March 2018, SB18-009 was signed into law, establishing that Colorado electricity consumers have the right to own, install, and interconnect energy storage systems without unnecessary restrictions and/or discriminatory rates or fees. The bill instructs the Public Utilities Commission to implement rules reflecting these principles, and specifically states that utilities will not be allowed to require customers to install additional meters for the purpose of monitoring energy storage equipment.	CO	x			x	29.4	38.2	0	NCCETC (2018) <a href="https://leg.colorado.gov/bills/sb18-009">https://leg.colorado.gov/bills/sb18-009</a>
Incentives & Financing	Grant Program			Connecticut Public Act No. 16-196 (2012) established a grant and loan program for private/institutional microgrid systems.	CT		x		x	4.6	39.1	23.7	NGA (2016); <a href="https://www.cga.ct.gov/2016/ACT/pa/2016PA-00196-R00SB-00272-PA.htm">https://www.cga.ct.gov/2016/ACT/pa/2016PA-00196-R00SB-00272-PA.htm</a> .
Planning & Access	Wholesale Market Rules			Public Act 15-107 allowed for storage to be included in small-scale energy solicitations, in line with the treatment of renewable and energy efficiency offerings.	CT		x		x	4.6	39.1	23.7	IREC (2017).
Utility-Driven Demonstrations	Energy Storage Proposals	Planning & Access	Grid Modernization Planning	Public Act 15-5, Sec. 103 directed electric distribution companies (EDCs) to propose grid enhancement projects, specifically including DERs and storage resources.	CT		x		x	4.6	39.1	23.7	IREC (2017); NGA (2016)
Utility-Driven Demonstrations	Energy Storage Proposals	Planning & Access	Grid Modernization Planning	In June 2017, United Illuminating Company submitted its DER integration plan. The plan includes the following projects: (1) DER hosting capacity analysis and mapping, (2) DER and load forecasting, and (3) localized targeting of DERs. This proposal is submitted pursuant to Connecticut General Statutes § 16-244w, which requires the utilities to build grid-side system enhancements to integrate DERs.	CT		x			4.6	39.1	23.7	NCCETC (2018)
Utility-Driven Demonstrations	Energy Storage Proposals			In November 2017, the United Illuminating Company filed a Grid-Connected Battery Storage Proposal as part of its DER Integration Plan. This part of the pilot program allows the electric distribution companies to build, own, and operate grid-side system enhancements, including battery storage technologies. All projects must be cost-effective and maximize value to ratepayers.	CT		x		x	4.6	39.1	23.7	NCCETC (2018)
Process & Approvals	Interconnection			In November 2017, the DC Public Service Commission published a Notice of Proposed Rulemaking adding new definitions for customer generator, battery, back up generation, energy storage, microgrid, smart inverter, and others to its Small Generator Interconnection and Net Metering rules.	DC			x	x	57.1	42.9	0	NCCETC (2018)
Business Model & Rate Reform	Utility Business Model Reform	Process & Approvals	Energy Storage Ownership	S.B. 2462 allows the Public Utilities Commission to require electric cooperatives to disengage from owning generation, while providing a transition period for conversion to third-party power purchase agreements.	HI	x			x	20.8	0	0	NCCETC (2018); <a href="https://www.capitol.hawaii.gov/session2018/bills/SB2462.pdf">https://www.capitol.hawaii.gov/session2018/bills/SB2462.pdf</a>
Business Model & Rate Reform	Utility Business Model Reform			S.B. 2939, signed into law in April 2018, introduces performance-based ratemaking to Hawaii. The bill requires the Public Utilities Commission to develop performance incentives and penalty mechanisms by 2020 that directly tie utility revenues to each utility's achievement of certain performance metrics (e.g., public access to electric system planning data and aggregated customer energy use data, rapid integration of renewable energy, quality interconnection of customer-sited resources, timely interconnection of competitive procurements or energy).	HI	x			x	20.8	0	0	NCCETC (2018); <a href="http://docket.images.azcc.gov/0000175087.pdf">http://docket.images.azcc.gov/0000175087.pdf</a>



Incentives & Financing	Rebate Program			H.B. 1593 would create the Energy Savings Jump Start Program within the Hawaii Green Infrastructure Authority. Among other things, the Energy Savings Jump Start Program would include a rebate program for residential, commercial, and utility-scale energy storage systems. The bill was passed by the House in March 2017. The House rejected amendments made by the Senate in April, and the bill was sent to conference committee. The bill was carried over to 2018.	HI	x		x	20.8	0	0	NCCETC (2018); <a href="https://www.capitolof.hawaii.gov/session2018/bills/HB1593_SD2_.pdf">https://www.capitolof.hawaii.gov/session2018/bills/HB1593_SD2_.pdf</a>
Incentives & Financing	Tax Credit			S.B. 2100 would create a tax credit for energy storage systems, starting at 35% of costs and declining to 10% by 2027. The bill passed the Senate in March, was amended by the House, passed, and returned to the Senate in April. The Senate disagreed with the House amendments, and both chambers will be meeting in conference.	HI	x		x	20.8	0	0	NCCETC (2018); <a href="https://www.capitolof.hawaii.gov/session2018/bills/SB2100_HD2_.pdf">https://www.capitolof.hawaii.gov/session2018/bills/SB2100_HD2_.pdf</a>
Mandates	RPS			As of June 2015, Hawaii adopted a requirement that, by 2045, 100% of electricity sales must be generated from renewables.	HI	x		x	20.8	0	0	K&L Gates (2018)
Process & Approvals	Energy Storage Compensation	Business Model & Rate Reform	Rate Design	Hawaii phased out traditional net metering in 2015, adopting new interim tariffs and initiating a discussion on successors to these tariffs. The new Smart Export Program targets customers with solar PV and battery storage, with storage systems recharging the battery during the day and discharging in the evening. Customers may power their homes with the battery in the evening or export to the grid in exchange for a monetary credit on their electricity bill. The credit rates range from \$0.11 per kWh to \$0.21 per kWh, depending on the island.	HI	x		x	20.8	0	0	NCCETC (2018), K&L Gates (2018)
Process & Approvals	Energy Storage Compensation			The 2018 HPU Smart Export program authorizes electricity generated by rooftop PV and stored onsite to be used at night, with credits offered for excess generation exported back to the grid.	HI	x		x	20.8	0	0	K&L Gates (2018)
Process & Approvals	Permitting Process			Introduced in January 2018, H.B. 2469 would prohibit a county or state agency from approving a permit to construct or operate a new grid-connected energy storage facility in excess of 50 MWh if it is located in a sea level rise exposure area.	HI	x		x	20.8	0	0	NCCETC (2018)
Utility-Driven Demonstrations	Grid Modernization			In July 2017, Commonwealth Edison (ComEd) filed a petition for approval of a distribution microgrid pilot project, including 500 kW in battery storage capacity in the first phase. In February 2018, the Commission issued a final order approving the project, with stipulations requiring ComEd and Commission Staff to file a report looking into how to incorporate more distributed energy resources into the project.	IL		x	x	9.6	31.6	25.8	NCCETC (2018)
Planning & Access	Integrated Resource Planning			As part of the Public Service Commission Staff's proposed modified net metering rules filed in November 2017, utilities would be required to document the current level of DG in their service territories, discuss and analyze the impact that DG is having on the system resource requirements, and forecast future DG for at least a five-year period. Utilities would be encouraged to provide analysis or documentation on the monetary value of the avoided energy and capacity benefits provided by DG historically and forecasted into the future.	LA	x		x	3.7	70.1	8.8	NCCETC (2018)
Planning & Access	Wholesale Market Rules			In April 2017, DTE Electric submitted a request to update energy storage tariffs. In December of that year, MISO released its Energy Storage Task Force charter. The Task Force will conduct a series of meetings in early 2018 to consider various issues pertaining to the integration of energy storage.	MI			x	15	35.7	14.1	NCCETC (2018)
Process & Approvals	Energy Storage Compensation			H.B. 4220 (2017) authorizes customers to opt out of advanced meter installation.	MI			x	15	35.7	14.1	NCCETC (2018)
Utility-Driven Demonstrations	Energy Storage Proposals	Utility-Driven Demonstrations	Grid Modernization	As part of the Public Service Commission's February 2017 order in a Consumers Energy Company general rate case, Consumers Energy was directed to submit a distribution investment and maintenance plan by August of that year. The subsequent plan included demand response programs and battery storage pilot projects.	MI			x	15	35.7	14.1	NCCETC (2018)
Utility-Driven Demonstrations	Energy Storage Proposals	Utility-Driven Demonstrations	Grid Modernization	As part of the Public Service Commission's January 2017 order in DTE Electric's general rate case, DTE was directed to submit a distribution investment and maintenance plan by July of that year. The subsequent plan included a variety of grid modernization investments, but ultimately found that energy storage was not economical in light of other available alternatives.	MI			x	15	35.7	14.1	NCCETC (2018)
Incentives & Financing	Grant Program			H.B. 3113 and S.B. 2712 would appropriate an unspecified amount of money to fund an energy storage demonstration project grant program to be administered by the Department of Commerce. The bills were introduced in February 2018.	MN	x		x	27	30.8	10.3	NCCETC (2018); <a href="https://www.revisor.mn.gov/bills/bill.php?f=SF2712&amp;b=senate&amp;y=2018&amp;ssn=0">https://www.revisor.mn.gov/bills/bill.php?f=SF2712&amp;b=senate&amp;y=2018&amp;ssn=0</a>
Mandates	Energy Storage Target			H.B. 3115 and S.B. 2711 would create an energy storage procurement target for utilities in the state. The current form of the bill does not specify the specific target, but sets an achievement date of December 31, 2023. The bills were introduced in February 2018.	MN	x		x	27	30.8	10.3	NCCETC (2018); <a href="https://www.revisor.mn.gov/bills/bill.php?f=SF2711&amp;b=senate&amp;y=2018&amp;ssn=0">https://www.revisor.mn.gov/bills/bill.php?f=SF2711&amp;b=senate&amp;y=2018&amp;ssn=0</a>
Planning & Access	Integrated Resource Planning			H.B. 3114 and S.B. 2710, introduced in February 2018, would make energy storage a part of the integrated resource planning process.	MN	x		x	27	30.8	10.3	NCCETC (2018); <a href="https://www.revisor.mn.gov/bills/bill.php?b=senate&amp;f=st2710&amp;ssn=0&amp;y=2018">https://www.revisor.mn.gov/bills/bill.php?b=senate&amp;f=st2710&amp;ssn=0&amp;y=2018</a>
Planning & Access	Integrated Resource Planning			S.B. 3266, introduced in March 2018, would make energy storage a part of the integrated resource planning process.	MN	x		x	27	30.8	10.3	NCCETC (2018); <a href="https://www.revisor.mn.gov/bills/bill.php?f=SF3266&amp;b=senate&amp;y=2018&amp;ssn=0">https://www.revisor.mn.gov/bills/bill.php?f=SF3266&amp;b=senate&amp;y=2018&amp;ssn=0</a>
Process & Approvals	Energy Storage Cost Recovery			H.B. 3112 and S.B. 2714 provide a set of conditions under which a utility may petition the Public Utilities Commission for cost recovery of an energy storage pilot project. The bills were introduced in February 2018.	MN	x		x	27	30.8	10.3	NCCETC (2018); <a href="https://www.revisor.mn.gov/bills/bill.php?f=SF2714&amp;b=senate&amp;y=2018&amp;ssn=0">https://www.revisor.mn.gov/bills/bill.php?f=SF2714&amp;b=senate&amp;y=2018&amp;ssn=0</a>
Process & Approvals	Energy Storage Cost Recovery			H.B. 3116 and S.B. 2713 would allow a public utility to petition the Public Utilities Commission for an advance determination of prudence for an energy storage system. If granted, the utility may begin recovering costs in either the next rate case or through a rider approved by the Commission. Both bills were introduced in February 2018.	MN	x		x	27	30.8	10.3	NCCETC (2018); <a href="https://www.revisor.mn.gov/bills/bill.php?f=SF2713&amp;b=senate&amp;y=2018&amp;ssn=0">https://www.revisor.mn.gov/bills/bill.php?f=SF2713&amp;b=senate&amp;y=2018&amp;ssn=0</a>
Process & Approvals	Interconnection			The Minnesota Public Utilities Commission has an open proceeding to update the state's interconnection standards. Numerous parties participated in working groups and submitted comments throughout 2017. The Commission opened a comment period in February 2018 to receive input on the Commission Staff's recommended updates to the interconnection standards. The updated standards are based on FERC's Small Generation Interconnection Procedures, and includes provisions to allow energy storage, both connected to a small generator, and as a standalone device.	MN	x		x	27	30.8	10.3	NCCETC (2018). See also IREC (2017).
Planning & Access	Integrated Resource Planning			In February 2017, the New Mexico Public Regulation Commission initiated a rulemaking to include energy storage in IRP filings.	NM	x		x	19.7	38.7	0	IREC (2017); <a href="http://www.nmprc.state.nm.us/ssfeedfiles/pressreleases/2017-8-8CommissionUnanimouslyApprovesAmendingRuleToIncludeEnergyStorage.pdf">http://www.nmprc.state.nm.us/ssfeedfiles/pressreleases/2017-8-8CommissionUnanimouslyApprovesAmendingRuleToIncludeEnergyStorage.pdf</a>
Business Model & Rate Reform	Time-Varying Rates	Process & Approvals	Energy Storage Compensation	A.B. 405 (June 2017) requires utilities to establish optional time-variable rates, including those for energy storage.	NV	x		x	30.1	61.4	0	NCCETC (2018)

Business Model & Rate Reform	Utility Business Model Reform			The first of two required even-year votes on a state constitutional amendment to deregulate the electric utility industry was held in November 2016, with a majority of voters approving deregulation. A vote on whether to adopt the amendment ultimately failed in November 2018. The Public Utilities Commission of Nevada (PUCN) had opened a docket to consider multiple issues that would arise from deregulation, including timelines for implementation, necessary changes in state law, and options for developing wholesale and retail markets.	NV	x		x	30.1	61.4	0	NCCETC (2018); Docket No. 17-10001
Incentives & Financing	Rebate Program			S.B. 145, as amended, created incentives for energy storage systems. Program rules are to be determined through subsequent regulations issued by the Public Utilities Commission of Nevada (PUCN).	NV	x		x	30.1	61.4	0	NCCETC (2018), Governor's Office of Energy (2017).
Mandates	Energy Storage Target	Analysis, R&D, & Market Support	Energy Storage Study	S.B. 204 requires the Public Utilities Commission of Nevada (PUCN) to determine if it is in the public interest to adopt a state energy storage procurement requirement.	NV	x		x	30.1	61.4	0	NCCETC (2018), K&L Gates (2018), Governor's Office of Energy (2017).
Planning & Access	Distribution Resource Plan Requirement	Planning & Access	Integrated Resource Planning	SB 146 requires utilities to develop a distributed resources plan within the IRP, including the costs and benefits of DER (i.e., DG, EE, storage, EVs, DR).	NV	x		x	30.1	61.4	0	Governor's Office of Energy (2017).
Process & Approvals	Interconnection			A.B. 405 provides assurances of timely solar+storage system interconnection.	NV	x		x	30.1	61.4	0	K&L Gates (2018), NCCETC 2018
Business Model & Rate Reform	Utility Business Model Reform			As part of National Grid's general rate case and Power Sector Transformation investment plan filed in November 2017, the utility proposed first steps to shift toward performance-based regulation. Proposed performance incentives fall into three categories: (1) system efficiency, (2) distributed energy resources, and (3) network support services. Technical sessions were held in January and February 2018, and an evidentiary hearing was scheduled for October 2018.	RI		x	x	6.1	93.9	0	NCCETC (2018); <a href="http://www.ripuc.nj.gov/utilityinfo/electric/PST%20R-eport_Nov_8.pdf">http://www.ripuc.nj.gov/utilityinfo/electric/PST%20R-eport_Nov_8.pdf</a>
Utility-Driven Demonstrations	Energy Storage Proposals	Utility-Driven Demonstrations	Grid Modernization	In November 2017, National Grid proposed a portfolio of grid modernization investments ("Power System Transformation") as part of its effort to implement work done in the Power Sector Transformation investigation process. The proposal includes the deployment of AMI, a 2 MWh energy storage demonstration project, and several smart grid investments, including foundational information system and cybersecurity investments, a system data portal, distribution feeder monitoring, data system control enhancements, and geographic information system enhancements.	RI		x	x	6.1	93.9	0	NCCETC (2018); <a href="http://www.ripuc.nj.gov/utilityinfo/electric/PST%20R-eport_Nov_8.pdf">http://www.ripuc.nj.gov/utilityinfo/electric/PST%20R-eport_Nov_8.pdf</a>
Mandates	Energy Storage Target			H.B. 501 directs the Department of Public Service to develop policy recommendations and targets for energy storage capacity in the state, particularly for systems storing electricity from intermittent sources. The full text of the bill is not yet available. The bill was not voted on during the 2017 legislative session. Legislation may carry over from an odd-numbered year to an even-numbered year.	VT	x		x	85.8	0	0	NCCETC (2018)
Planning & Access	Clean Peak Standard/RPS			Act 56 (2016) included Tier III targets for Renewable Energy Standard allows for small contribution of "energy transformation projects" (2% of 2017 sales; 12% of 2032 sales), including the deployment of infrastructure to facilitate grid energy storage.	VT	x		x	85.8	0	0	VDPS (2017)
Planning & Access	Non-Wires Alternatives			Anticipation of inclusion of storage in discussion of microgrids in the context of the state Energy Assurance Plan. Initial stakeholder discussions to frame update of state EAP were slated to begin early 2018. A broader suite of both short- and long-term research and planning are also included in general recommendations for incorporating storage for energy assurance purposes.	VT	x		x	85.8	0	0	VDPS (2017)
Process & Approvals	Interconnection			Process underway to revise interconnection standards under rule 5.500. Though existing interconnection standards implicitly allow for energy storage (as evidenced by Green Mountain's past energy storage projects), revisions are intended to explicitly address storage by including storage that is not associated with a generator under the definition of a "generation resource".	VT	x		x	85.8	0	0	VDPS (2017); <a href="http://puc.vermont.gov/about-us/statutes-and-rules/proposed-changes-rule-5500">http://puc.vermont.gov/about-us/statutes-and-rules/proposed-changes-rule-5500</a> .
Utility-Driven Demonstrations	Energy Storage Proposals			In April 2017, Green Mountain Power (GMP) filed a request for a Certificate of Public Good for its proposed Panton Battery Storage Project. The project would be a 1 MW/4MWh Tesla Powerpack 2.0 battery system and located on the site of its existing 4.9 MW Solar Panton Project. GMP plans to stack values that the battery project can provide, with the primary values being peak shaving and regulation. The Commission held a technical hearing in December 2017 to further develop the evidentiary record, and approved the project in January 2018.	VT	x		x	85.8	0	0	NCCETC (2018)
Utility-Driven Demonstrations	Energy Storage Proposals	Utility-Driven Demonstrations	Grid Modernization	In November 2017, Green Mountain Power filed a request for a Certificate of Public Good for its proposed MicroGrid-Milton Project. The proposed project is a microgrid, including a 4.99 MW solar facility and a 2 MW battery storage facility (2 MW/8 MWh Tesla Powerpack.) A public hearing was held in January 2018, and a technical hearing is scheduled for September 2018.	VT	x		x	85.8	0	0	NCCETC (2018)
Utility-Driven Demonstrations	Energy Storage Proposals	Utility-Driven Demonstrations	Grid Modernization	In December 2017, Green Mountain Power filed a request for a Certificate of Public Good for its proposed MicroGrid-Ferriburgh Project. The proposed project is a microgrid, including a 4.99 solar facility and a 2 MW battery storage facility (2 MW/8 MWh Tesla Powerpack.) Later in December, the Public Utility Commission issued an order, finding the application incomplete. Green Mountain Power refiled its petition in March 2018, which the Commission found complete. A prehearing conference is scheduled for May 8, 2018.	VT	x		x	85.8	0	0	NCCETC (2018)
Analysis, R&D, & Market Support	Energy Storage Study			Act 53 directed the Department of Public Service to prepare a report on deploying energy storage on Vermont's transmission and distribution system. The report was to examine actions affecting energy storage deployment; federal and state jurisdictional issues; opportunities for, benefits of, and barriers to energy storage deployment; regulatory options and structures that can foster energy storage; and potential methods for fostering the development of cost-effective energy storage and the benefit and cost impacts on ratepayers. The report was published in October 2017.	VT	x		x	85.8	0	0	<a href="https://legislature.vermont.gov/assets/Documents/2018/Docs/ACTS/ACT053/ACT053%20A5%20Enacted.pdf">https://legislature.vermont.gov/assets/Documents/2018/Docs/ACTS/ACT053/ACT053%20A5%20Enacted.pdf</a>
Incentives & Financing	Grant Program			Washington Clean Energy Fund (2013) offers smart grid grants for developing utility scale energy storage technology.	WA	x		x	81	10.9	3.7	K&L Gates (2018), NGA (2016)
Planning & Access	Integrated Resource Planning	Planning & Access	Grid Modernization Planning	Two overlapping proceedings were initiated by the Washington Utilities and Transportation Commission staff in 2015 (UE-151069) and 2016 (U-161024) to assess the role of energy storage in utility planning and to assess possible changes to the integrated resource planning (IRP) process. A final report and policy statement was released by the Commission in October 2017, and a subsequent report on current practices in DER planning was issued in January 2018.	WA	x		x	81	10.9	3.7	NCCETC (2018)
Planning & Access	Integrated Resource Planning			Draft Utilities and Transportation Commission policy statement in 2017 directing investor-owned utilities to evaluate energy storage in IRPs. Draft and associated comments still under consideration as of April 2018.	WA	x		x	81	10.9	3.7	K&L Gates (2018)

Planning & Access	Integrated Resource Planning			In 2017, the Washington Utilities and Transportation Commission issued a statement that investor-owned utilities are to assess energy storage options in the context of an IRP before selecting other generation resources, as well as the applicability of cost recovery mechanisms to IOU expenditures on energy storage.	WA	x			81	10.9	3.7	K&L Gates (2018)
Planning & Access	Integrated Resource Planning	Process & Approvals	Defining Storage Services	To assist in the evaluation of storage in the context of IRPs, the Washington State Utilities and Transportation Commission (UTC) specifically identifies the Battery Storage Evaluation Tool (BSET) created by the Pacific Northwest National Laboratory (PNL) and StorageVet models (Docket UE-151069, 2017).	WA	x			81	10.9	3.7	<a href="https://www.utc.wa.gov/_layouts/15/CasesPublicWebsite/GetDocument.aspx?docID=67&amp;year=2015&amp;docketNumber=151069">https://www.utc.wa.gov/_layouts/15/CasesPublicWebsite/GetDocument.aspx?docID=67&amp;year=2015&amp;docketNumber=151069</a>
Incentives & Financing	On-Bill Financing			H.B. 374 would create an on-bill financing program for energy efficiency and conservation improvements. The bill was amended in April 2018 to explicitly allow energy storage devices to be eligible for financing under this program.	AK	x			21.3	46.7	0	NCCETC (2018) <a href="http://www.legis.state.ak.us/PDF/30/Bills/HB0374_C.PDF">http://www.legis.state.ak.us/PDF/30/Bills/HB0374_C.PDF</a>
Analysis, R&D, & Market Support	Research Support			Energy storage research funding provided by the state Energy Commission through an Electric Program Investment Charge.	CA		x		42.7	53.7	2.9	NGA (2016)
Incentives & Financing	Low-Income Incentive Program			In February 2018, San Diego Gas & Electric filed for approval of its 2018 Energy Storage and Procurement Plan, which includes an energy storage incentive program for low-income customers.	CA		x		42.7	53.7	2.9	<a href="https://www.sdge.com/sites/default/files/regulatory/AB%202868%20application%20Final%20Draft.pdf">https://www.sdge.com/sites/default/files/regulatory/AB%202868%20application%20Final%20Draft.pdf</a>
Incentives & Financing	Low-Income Incentive Program			In March 2018, Southern California Edison filed for approval of its 2018 Energy Storage and Procurement Plan, which includes approximately \$10 million for energy storage at low-income multifamily dwellings.	CA		x		42.7	53.7	2.9	K&L Gates (2018)
Planning & Access	Roadmap Development	Planning & Access	Integrated Resource Planning	2014 Energy Storage Roadmap developed by the California Independent System Operator (CAISO), the California Public Utilities Commission (CPUC), and the California Energy Commission solicited input from several hundred stakeholders so as to identify state regulatory and processes needs to facilitate storage. The roadmap also identified interventions to address identified needs, the entities best suited to take the lead on addressing needs, and the relative priority of actions.	CA		x		42.7	53.7	2.9	California ISO et al. (2014); <a href="https://www.caiso.com/documents/advancing-maximizingvalueofenergystoragetechnology_californiaroadmap.pdf">https://www.caiso.com/documents/advancing-maximizingvalueofenergystoragetechnology_californiaroadmap.pdf</a>
Incentives & Financing	Rebate Program			The Self-Generation Incentive Program (SGIP) provides rebates for energy storage systems. It has undergone multiple rounds of modification since its inception to ensure that funding is available for both small and large projects, that the program is available to low-income communities, and, in the case of current proceedings as of October 2018, that projects help to reduce greenhouse gas emissions.	CA		x		42.7	53.7	2.9	NCCETC (2018), K&L Gates (2018)
Incentives & Financing	Rebate Program			A.B. 2695, introduced in February 2018, would increase the budget for the Self-Generation Incentive Program by \$140 million, with the additional money reserved for energy storage projects for low and middle income consumers.	CA		x		42.7	53.7	2.9	NCCETC (2018)
Mandates	Energy Storage Target			In 2013, the California Public Utilities Commission (CPUC) adopted an energy storage mandate. The mandate requires that investor owned utilities procure a total of 1,325 MW of energy storage capacity by 2020 (installed no later than 2024).	CA		x		42.7	53.7	2.9	NCCETC (2018), K&L Gates (2018), NGA (2016). Also noted in VDPS (2017) and IREC (2017).
Mandates	Energy Storage Target			S.B. 1347, introduced in February 2018, would require the state's three IOUs to collectively procure an additional 2,000 MW of energy storage by January 1, 2020.	CA		x		42.7	53.7	2.9	NCCETC (2018); <a href="https://leginfo.ca.gov/faces/billTextClien nt.xhtml?bill_id=201720180SB1347">https://leginfo.ca.gov/faces/billTextClien nt.xhtml?bill_id=201720180SB1347</a>
Mandates	Energy Storage Target			California AB 2868 (2016) requires up to 500MW of additional distribution-connected or BTM storage with at least 10 years of useful life.	CA		x		42.7	53.7	2.9	K&L Gates (2018)
Planning & Access	Clean Peak Standard/RPS			California SB 338 (2017) requires CPUC and utilities to consider ES in meeting peak demand more aligned with climate and renewable goals. Overall goal is T&D and generation capacity deferral.	CA		x		42.7	53.7	2.9	K&L Gates (2018)
Planning & Access	Distribution Resource Plan Requirement			California AB 327 (2013) requires distribution resource plans to be developed by IOUs.	CA		x		42.7	53.7	2.9	NGA (2016); <a href="https://leginfo.ca.gov/faces/billNavClient.xhtml?bill_id=201320140AB327">https://leginfo.ca.gov/faces/billNavClient.xhtml?bill_id=201320140AB327</a> .
Planning & Access	Modernization Planning			In decision 18-01-003 (January 2018), the California Public Utilities Commission (CPUC) adopted multiple rules and definitions governing how energy storage could participate in grid through multiple use applications (i.e., stacking).	CA		x		42.7	53.7	2.9	<a href="http://docs.cpuc.ca.gov/PublishedDocs/Published/G000/M206/K462/206462341.PDF">http://docs.cpuc.ca.gov/PublishedDocs/Published/G000/M206/K462/206462341.PDF</a>
Planning & Access	Integrated Resource Planning			California SB 350 (2015) requires an assessment of energy storage in the resource planning process.	CA		x		42.7	53.7	2.9	NGA (2016); California Energy Commission (CEC). Clean Energy & Pollution Reduction Act SB 350 Overview ( <a href="https://www.energy.ca.gov/sb350/">https://www.energy.ca.gov/sb350/</a> )
Planning & Access	Open-Access Grid Data	Mandates	Energy Storage Target	California SB 801 (2018) requires munis that provide electric service to 250,000 customers in LA basin to: (1) share electric grid data (2) reduce loads without increasing gas-fired generation, and (3) evaluate the cost-effectiveness of 100MW of energy storage in basin.	CA		x		42.7	53.7	2.9	K&L Gates (2018)
Process & Approvals	Energy Storage Compensation			A January 2016 decision from the California Public Utilities Commission (CPUC) established a successor tariff to replace net metering when the utilities reach their aggregate caps. Part of this discussion has included net metering options for PV systems paired with energy storage.	CA		x		42.7	53.7	2.9	NCCETC (2018). See also <a href="https://www.utilitydive.com/news/residential-storage-hits-new-record-deploying-36mwh-in-q1/528535/">https://www.utilitydive.com/news/residential-storage-hits-new-record-deploying-36mwh-in-q1/528535/</a> .
Process & Approvals	Permitting Process			AB 546 (2017) specifies that local governments must offer BTM permit applications for energy storage systems online.	CA		x		42.7	53.7	2.9	K&L Gates (2018)
Utility-Driven Demonstrations	Energy Storage & Procurement Plan			In March 2018, Pacific Gas & Electric filed for approval of its 2018 Energy Storage and Procurement Plan, which includes the deployment of 166 MW of energy storage. Like its previous Energy Storage Procurement Plans, Pacific Gas & Electric plans to reach its deployment target through requests for offers. A prehearing conference was scheduled for May 1, 2018 and resulted in a 162.5 MW project	CA		x		42.7	53.7	2.9	<a href="https://www.pge.com/en/about/newsroom/newsdetails/index.page?title=20180629_pge_proposes_our_new_cost-effective_energy_storage_projects_to_cpuc">https://www.pge.com/en/about/newsroom/newsdetails/index.page?title=20180629_pge_proposes_our_new_cost-effective_energy_storage_projects_to_cpuc</a>
Utility-Driven Demonstrations	Energy Storage & Procurement Plan			In February 2018, San Diego Gas & Electric filed for approval of its 2018 Energy Storage and Procurement Plan, which includes the deployment of 166 MW of energy storage. A prehearing conference was scheduled for May 1, 2018.	CA		x		42.7	53.7	2.9	<a href="https://www.energy-storage.news/news/california-utility-sdgc-seeks-166mw-energy-storage-as-public-emergency-resp">https://www.energy-storage.news/news/california-utility-sdgc-seeks-166mw-energy-storage-as-public-emergency-resp</a> (accessed October 18, 2018)
Utility-Driven Demonstrations	Energy Storage & Procurement Plan			In March 2018, Southern California Edison filed for approval of its 2018 Energy Storage and Procurement Plan, which includes the procurement of a minimum of 20 MW of energy storage. The proposal includes a solicitation for approximately 40 MW of utility-owned energy storage and a \$9.8 million incentive program for energy storage installations at low-income multifamily dwellings.	CA		x		42.7	53.7	2.9	<a href="http://www3.sce.com/sscc/law/dis/dbattach5e.nsf/0/44AA57950E854D6882582430078D21D/\$FILE/A1803XXX-SC%202018%20Energy%20Storage%20Procurement%20and%20Investment%20Plan%20Application.pdf">http://www3.sce.com/sscc/law/dis/dbattach5e.nsf/0/44AA57950E854D6882582430078D21D/\$FILE/A1803XXX-SC%202018%20Energy%20Storage%20Procurement%20and%20Investment%20Plan%20Application.pdf</a>
Utility-Driven Demonstrations	Energy Storage Proposals			In December 2017, Pacific Gas & Electric filed for approval of six energy storage agreements resulting from its 2016-2017 Request for Offers. The projects total 165 MW of energy storage capacity. Southern California Edison also filed an application for 10 MW of battery storage.	CA		x		42.7	53.7	2.9	<a href="https://www.windpowerengineering.com/projects/pge-expands-energy-storage-initiatives/">https://www.windpowerengineering.com/projects/pge-expands-energy-storage-initiatives/</a>

Planning & Access	Integrated Resource Planning	Process & Approvals	Defining Storage Services	StorageVET is being used in California to conduct analysis for resource procurement and long-term planning by load-serving entities (LSEs) and to conduct analysis by non-utility entities of storage value.	CA	x	42.7	53.7	2.9	<a href="http://www.energy.ca.gov/2017publications/CEC-500-2017-016/CEC-500-2017-016-APC.pdf">http://www.energy.ca.gov/2017publications/CEC-500-2017-016/CEC-500-2017-016-APC.pdf</a>
Process & Approvals	Interconnection			New interconnection rules were adopted in December 2016 that specifically include energy storage in the definition of eligible facilities and that also include clarify the applicability of certain provisions to storage.	IA	x	39.7	17.2	3.5	IREC (2017).
Business Model & Rate Reform	Fixed Charges	Business Model & Rate Reform	Time-Varying Rates	H.B. 1725 would require that distribution companies offer a time-of-use rate option, provide an overview of different rate options and an estimate of associated impacts to a customer's bill, and provide bill protection for customers deciding to adopt time-of-use rates.	MA	x	21.7	42.8	5.1	NCCETC (2018)
Incentives & Financing	Developer Incentive			The Massachusetts Energy Storage Initiative is a multipronged effort to encourage storage development in the state, including demonstration project funding. The 2016 study was intended to examine the national and state storage industry landscape, economic development and market opportunities for storage in the state, and potential policies and programs to support storage deployment. The study was to provide policy and regulatory recommendations along with a cost-benefit analysis.	MA	x	21.7	42.8	5.1	K&L Gates (2018); VDPS (2017). See also <a href="https://www.mass.gov/energy-storage-initiative">https://www.mass.gov/energy-storage-initiative</a> .
Analysis, R&D, & Market Support	Energy Storage Study				MA	x	21.7	42.8	5.1	<a href="https://www.mass.gov/service-details/energy-storage">https://www.mass.gov/service-details/energy-storage</a>
Incentives & Financing	Financing Program			The Massachusetts Advancing Commonwealth Energy Storage (ACES) Program under the Massachusetts Clean Energy Center provides grants for Massachusetts-based projects that have already secured significant project funding (>50%). Legislation enacted in April 2016 directed the Department of Energy Resources (DOER) to develop a new solar incentive program to succeed the Solar Renewable Energy Credit II (SREC II) Program. The new program takes the form of a performance-based incentive and includes an adder for solar + storage systems. In August 2017, DOER filed the final version of the regulation, and the state's distribution utilities jointly filed a model SMART tariff in September of that year.	MA	x	21.7	42.8	5.1	K&L Gates (2018)
Incentives & Financing	Performance-Based Incentive			Evidentiary hearings were held in late March 2018 and early April 2018. H.B. 2600 would provide multiple financial incentives for energy storage manufacturing and installation, including a rebate for Massachusetts-based companies that install or manufacture energy storage systems, authorization for municipalities to exempt storage from property taxes, and adopting a sales tax exemption for storage systems until the end of 2025.	MA	x	21.7	42.8	5.1	NCCETC (2018), K&L Gates (2018)
Incentives & Financing	Rebate Program	Incentives & Financing	Tax Exemption		MA	x	21.7	42.8	5.1	NCCETC (2018)
Incentives & Financing	Solar + Storage Incentive			The 2017 Solar Massachusetts Renewable Target (SMART) program provides an additional financial benefit for solar projects that incorporate storage.	MA	x	21.7	42.8	5.1	K&L Gates (2018)
Mandates	Energy Storage Target			HB 1746 and SB 1874 would seek to establish a state target of 1,766 MW of energy storage by 2025, and also require that a 2030 deployment target be set by the end of 2020.	MA	x	21.7	42.8	5.1	NCCETC (2018)
Mandates	Energy Storage Target			A storage target of 200MWh by 2020 was introduced in 2017 as part of Energy Storage Initiative.	MA	x	21.7	42.8	5.1	K&L Gates (2018)
Planning & Access	Grid Modernization Planning			H.B. 1725 would require distribution utilities to regularly submit grid modernization plans that also assess the locational costs and benefits of energy resources, as well as any barriers to deployment of local energy resources.	MA	x	21.7	42.8	5.1	NCCETC (2018)
Planning & Access	Load Management Plan			Proposed in March of 2018, Massachusetts H. 4318 would encourage the consideration of storage in distribution company load management plans. In October 2017, the Department of Public Utilities (DPU) opened an inquiry into the net metering eligibility of solar plus storage systems (or energy storage paired with other types of eligible net metering systems), as well as the eligibility of net metering facilities to participate in the Forward Capacity Market. A technical conference was held in late January 2018.	MA	x	21.7	42.8	5.1	K&L Gates (2018)
Process & Approvals	Energy Storage Compensation				MA	x	21.7	42.8	5.1	NCCETC (2018); <a href="https://malegislature.gov/Bills/190/H4835">https://malegislature.gov/Bills/190/H4835</a>
Process & Approvals	ES Procurement Authority			Massachusetts H. 4568 (2016) authorized the Department of Energy Resources to determine whether a procurement target should be adopted. In response to a June 2014 Department of Public Utilities (DPU) grid modernization planning order, Eversource filed a August 2015 plan consisting of, among other elements, energy storage, voluntary time-varying rates, and consumer outreach and education efforts.	MA	x	21.7	42.8	5.1	NGA (2016); The Commonwealth of Massachusetts, Bill H. 4568, An Act to Promote Energy Diversity, ( <a href="https://malegislature.gov/Bills/189/House/H4568">https://malegislature.gov/Bills/189/House/H4568</a> ).
Utility-Driven Demonstrations	Grid Modernization				MA	x	21.7	42.8	5.1	NCCETC (2018)
Mandates	Clean Peak Standard	Mandates	Energy Storage Target	H 4857, signed into law in August 2018, establishes both a clean peak standard and an energy storage goal. The bill also includes other energy efficiency and renewable energy provisions (e.g., off-shore wind).	MA	x	21.7	42.8	5.1	<a href="https://malegislature.gov/Bills/190/H4857">https://malegislature.gov/Bills/190/H4857</a>
Business Model & Rate Reform	Time-Varying Rates			As part of Public Conference No. 44 (grid modernization), utilities were directed to develop time-varying rate pilot programs. A revised report with details on the proposed rate pilot programs was filed in February 2018. In 2017, Maryland became the first state to enact state income tax credits for energy storage systems, which are in effect through 2022. The tax credit is for up to \$5,000 for residential applications and is limited to the lesser of \$75,000 or 30 percent of system costs for commercial customers. A statewide annual tax credit cap of \$750,000 is also imposed.	MD	x	8.7	29.4	13.8	NCCETC (2018)
Incentives & Financing	Tax Credit				MD	x	8.7	29.4	13.8	MD DNR HB773 Initial Findings; <a href="http://dnr.maryland.gov/pprp/Documents/Draft-Initial-Findings-v2.pdf">http://dnr.maryland.gov/pprp/Documents/Draft-Initial-Findings-v2.pdf</a>
Planning & Access	Integrated Resource Planning			Maryland no longer requires electric distribution utilities to submit integrated resource plans, detailed explanations of utilities' long-term distribution system needs and investment strategies are provided in Distribution Investment Plans, as required by the Commission.	MD	x	8.7	29.4	13.8	MD DNR HB773 Initial Findings; <a href="http://dnr.maryland.gov/pprp/Documents/Draft-Initial-Findings-v2.pdf">http://dnr.maryland.gov/pprp/Documents/Draft-Initial-Findings-v2.pdf</a>
Process & Approvals	Interconnection			A rulemaking to consider reforms to state interconnection processes was initiated by the Maryland Public Service Commission in December 2017. The resulting proposal includes a specific reference of energy storage, revisions to the interconnection process for both large and small systems.	MD	x	8.7	29.4	13.8	NCCETC (2018)
Analysis, R&D, & Market Support	Energy Storage Study			In 2017, H.B. 773 directed the Maryland Power Plant Research Program to conduct a study of regulatory reforms and market incentives that are necessary or beneficial to increase the use of energy storage devices in the state. The Program is to consult with stakeholders to conduct the study.	MD	x	8.7	29.4	13.8	<a href="http://mgaleg.maryland.gov/2017RS/Chapters_noln/CH_382_hb0773e.pdf">http://mgaleg.maryland.gov/2017RS/Chapters_noln/CH_382_hb0773e.pdf</a>
Planning & Access	Non-Wires Alternatives			A June 2017 decision on net metering successor tariffs by the New Hampshire Public Utilities Commission's (PUC) included an order to implement four pilot programs, including one making use of non-wires alternatives.	NH	x	20.9	36.8	28.1	NCCETC (2018)

Utility-Driven Demonstrations	Energy Storage Proposals			In December 2017, Liberty Utilities filed an application to implement a battery storage pilot program, in which the utility will deploy 5 MW total of battery storage equipment at the homes of 1,000 residential customers. Participating customers would have control over the battery systems, except when a peak demand is predicted for the next day. The utility proposed inclusion of the battery costs in its rate base and applying a monthly charge to participating customers' bills. The utility is also requesting approval for a time-of-use rate for participants, which includes critical peak, on-peak, and off-peak periods.	NH	x	20.9	36.8	28.1	NCCETC (2018); <a href="https://www.utilitydive.com/news/is-new-hampshire-on-the-verge-of-battery-energy-storage-history/525876/">https://www.utilitydive.com/news/is-new-hampshire-on-the-verge-of-battery-energy-storage-history/525876/</a>
Business Model & Rate Reform	Time-Varying Rates			S.B. 603 and A.B. 3732, introduced in January and March 2018, directs the Board of Public Utilities to open a proceeding to allow the state's utilities to deploy AMI throughout their service territories. Upon completion of the Board's proceeding, each utility is to file a proposed smart meter procurement and installation plan. The bill states that utilities and electric power suppliers may offer TOU rates and real-time pricing programs after deploying AMI. The bill states that residential and commercial customers may elect to participate in these rate programs.	NJ	x	6.8	63.5	21.7	NCCETC (2018)
Incentives & Financing	Financing Program			S.B. 1611 and A.B. 1902 would allow energy storage systems and microgrids to be eligible for property assessed clean energy financing.	NJ	x	6.8	63.5	21.7	NCCETC (2018)
Mandates	Energy Storage Target			Companion bills A.B. 3459 and S.B. 813, introduced in March and January 2018, direct electric power generators to deploy 600 MW of energy storage by 2021 and 2,000 MW by 2030.	NJ	x	6.8	63.5	21.7	NCCETC (2018)
Mandates	Energy Storage Target			A.B. 3723, introduced in March 2018, creates an energy storage procurement target of 600 MW by 2021 and 2,000 MW by 2030.	NJ	x	6.8	63.5	21.7	NCCETC (2018)
Analysis, R&D, & Market Support	Energy Storage Study			A.B. 3723 also directed the Board of Public Utilities and PJM Interconnection to work with stakeholders to conduct an analysis examining how storage can provide benefits to ratepayers and promote electric vehicles; types of storage technologies; the benefits and costs to ratepayers, local governments, and utilities; the optimal amount of energy storage to add in the state over the next five years to maximize ratepayer benefits; the optimal locations for distributed energy resources; and the cost to ratepayers of adding the optimal amount of storage. The study is to quantify potential benefits and costs of increasing storage in the state and provide recommendations to increase storage opportunities, including financial incentive recommendations.	NJ	x	6.8	63.5	21.7	<a href="https://www.njleg.state.nj.us/2018/Bills/PL18/17">https://www.njleg.state.nj.us/2018/Bills/PL18/17</a>
Mandates	Energy Storage Target			H.B. 2193 (2015) required utilities serving at least 25,000 customers to procure at least one energy storage system with a storage capacity of at least 5 MWh. Also included in the legislation was instruction for the state Public Utility Commission (PUC) to establish guidelines for submission of energy storage proposals.	OR	x	73.6	22.9	0	NCCETC (2018), K&L Gates (2018), NGA (2016). Also noted in VDPS (2017) and IREC (2017).
Utility-Driven Demonstrations	Energy Storage Proposals	Incentives & Financing	Grant Program	The Oregon Department of Energy, with support from Sandia National Laboratories, offered a direct grant to promote a microgrid and energy storage demonstration project being implemented by the Eugene Water and Electric Board.	OR	x	73.6	22.9	0	As noted in DNR (2017), K&L Gates (2018); <a href="https://content.govdelivery.com/accounts/USDOE/SNLEC/bulletins/1ea8c62">https://content.govdelivery.com/accounts/USDOE/SNLEC/bulletins/1ea8c62</a>
Planning & Access	Integrated Resource Planning	Process & Approvals	Defining Storage Services	In compliance with HB 2193, in January 2017 the Public Utility Commission of Oregon (PUC) suggested utilities use the Battery Storage Evaluation Tool (BSET) or the Energy Storage Valuation Tool (ESVT) to estimate the value of energy storage applications. The PUC also granted a measure of flexibility to utilities to use tools of their choice, so long as the models chosen are both auditable and transparent.	OR	x	73.6	22.9	0	<a href="https://apps.puc.state.or.us/orders/2016ords/16-5">https://apps.puc.state.or.us/orders/2016ords/16-5</a>
Business Model & Rate Reform	Rate Design			Public Utility Commission of Texas (PUCT) Substantive Rule 25.192 exempts wholesale energy storage from transmission service rates. The rule also excludes wholesale storage load from coincident peak demand calculations.	TX	x	18.6	57.2	4.2	K&L Gates (2018)
Incentives & Financing	Grant Program			The Texas New Technology Implementation Grant Fund provides grants for renewable energy storage projects in targeted air quality areas.	TX	x	18.6	57.2	4.2	K&L Gates (2018)
Planning & Access	Non-Wires Alternatives			In February 2018, the Public Utility Commission of Texas opened this docket to address the use of non-traditional technologies for electric delivery service. This docket arises from a previous docket, No. 46368, which concerned AEP Texas North Company's request to deploy energy storage as a non-wires alternative. The earlier docket has been closed to allow for this wider investigation. A procedural schedule has not yet been set for this docket.	TX	x	18.6	57.2	4.2	NCCETC (2018) for Docket, K&L Gates (2018)
Process & Approvals	Defining Storage Services	Planning & Access	Wholesale Market Rules	Texas SB 943 (2011) clarified that energy storage technology, when used as generation assets, are considered generation assets. Energy storage must also register with the Public Utility Commission of Texas.	TX	x	18.6	57.2	4.2	NGA (2016); K&L Gates (2018). Also noted in VDPS (2017) and IREC (2017).
Process & Approvals	Wholesale Pricing	Process & Approvals	Defining Storage Services	PUCT Substantive Rule 25.501(m) defines wholesale storage, including such considerations as how it is charged, how it is metered, and how electricity stored is subsequently regenerated and sold.	TX	x	18.6	57.2	4.2	K&L Gates (2018)
Utility-Driven Demonstrations	Energy Storage Proposals			In February of 2018, a proceeding surrounding a proposal to install utility-scale lithium-ion batteries in the AEP Texas North Company distribution system was dismissed without prejudice, prompting a call for Commission Staff to undertake a rulemaking to create a regulatory framework for energy storage in ERCOT.	TX	x	18.6	57.2	4.2	NCCETC (2018)
Planning & Access	Non-Wires Alternatives			Open docket to consider NWA's (Docket 2011-00138), including implementation of the Boothbay Harbor Smart Grid Reliability Project (a transmission upgrade project featuring utility-scale energy storage).	ME		50.3	31.8	0	MDER et al. (2016); <a href="https://www.utilitydive.com/news/maine-turns-to-battery-storage-to-avoid-transmission-investment/400440/">https://www.utilitydive.com/news/maine-turns-to-battery-storage-to-avoid-transmission-investment/400440/</a>
Process & Approvals	Interconnection			In November 2017, the Maine Public Utilities Commission opened a rulemaking proceeding to amend the state's small generator interconnection rules. The Commission's proposed revisions do not address energy storage, but intervenor comments make a few suggestions related to interconnection of storage systems. The PUC approved amended interconnection rules in March 2018, which do not include amendments related to energy storage systems.	ME		50.3	31.8	0	NCCETC (2018)
Business Model & Rate Reform	Rate Design			In 2016, the NY Public Service Commission approved new rate models. The reformed regulatory model, converting from cost-of-service to market-based, was seen as posing potential challenge to energy storage. In the former, regulators can direct utilities to deploy storage. In the latter, deployment depends in part there being a value for services (e.g., peak reduction) or supportive rate designs.	NY		21.4	52	13.5	<a href="https://www.utilitydive.com/news/new-yorks-energy-storage-target-could-end-up-at-3-gw-by-2030/526895/">https://www.utilitydive.com/news/new-yorks-energy-storage-target-could-end-up-at-3-gw-by-2030/526895/</a>
Business Model & Rate Reform	Time-Varying Rates			S.B. 3093 created a Real Time Smart Meter program. Charges for customers in the program would be calculated from both the electricity used and the time it as used, along with a flat fee to cover transmission and service costs.	NY		21.4	52	13.5	NCCETC (2018)
Incentives & Financing	Grant Program			The NYSERDA Clean Energy Fund (2017) provides up to \$15.5 million for energy storage, to be doled out in multiple stages between 2017 and 2019.	NY		21.4	52	13.5	K&L Gates (2018)
Incentives & Financing	Tax Credit			A.B. 6235 creates a state tax credit (25% of costs, up to a maximum of \$7,000) for residential energy storage.	NY		21.4	52	13.5	NCCETC (2018)
Incentives & Financing	Tax Exemption			S.B. 6762 expands state property tax exemptions to include a variety of renewable and higher efficiency technologies, including energy storage.	NY		21.4	52	13.5	NCCETC (2018)

Mandates	Energy Storage Substation Mandate			A 2017 NYSPSC Order mandated investor owned utilities to deploy and have operating at least two separate energy storage projects by the end of 2018.	NY	21.4	52	13.5	K&L Gates (2018)
Mandates	Energy Storage Target			In January 2018, Governor Cuomo announced a statewide energy storage procurement target of 1,500 MW by 2025.	NY	21.4	52	13.5	NCCETC (2018); <a href="https://www.utilitydive.com/news/new-yorks-energy-storage-target-could-end-up-at-3-gw-by-2030/526895/">https://www.utilitydive.com/news/new-yorks-energy-storage-target-could-end-up-at-3-gw-by-2030/526895/</a>
Mandates	Energy Storage Target	Planning & Access	Roadmap Development	The 2016 NY Energy Storage Roadmap builds upon the 1GW by 2022 goal of the 2012 Roadmap to call for 2GW of storage by 2025 and 4GW by 2030. Developed by the Department of Public Service and New York State Energy Research and Development Authority to plan an approach and make recommendations to achieve a 1,500 MW energy storage target. Published in June 2018.	NY	21.4	52	13.5	NYSERDA Energy Storage Roadmap; <a href="http://documents.dps.ny.gov/public/Common/ViewDoc.aspx?DocRefId={2A1BFBC9-85B4-4DAE-BCAE-164B21B0DC3D}">http://documents.dps.ny.gov/public/Common/ViewDoc.aspx?DocRefId={2A1BFBC9-85B4-4DAE-BCAE-164B21B0DC3D}</a>
Analysis, R&D, & Market Support	Energy Storage Study			Legislation introduced in January 2017 requires the New York Public Service Commission to create a self-directed program for promoting renewable energy, microgrids, fuel cells, and energy storage technologies.	NY	21.4	52	13.5	<a href="https://www.ethree.com/wp-content/uploads/2018/06/NYS-Energy-Storage-Roadmap-6.21.2018.pdf">https://www.ethree.com/wp-content/uploads/2018/06/NYS-Energy-Storage-Roadmap-6.21.2018.pdf</a>
Mandates	Self-Directed Program			As part of New York's Reforming the Energy Vision (REV) proceeding, the Public Service Commission (PSC) is developing a methodology for DER valuation that provides a more precise and complete accounting of the values and costs of DERs, including energy storage, than traditional net metering.	NY	21.4	52	13.5	NCCETC (2018)
Process & Approvals	Energy Storage Compensation	Process & Approvals	Interconnection	NYSPSC CASE 15-E-0557 (2016) streamlined existing interconnection requirements.	NY	21.4	52	13.5	NCCETC (2018); <a href="https://rev.ny.gov/rev-demo-projects-1">https://rev.ny.gov/rev-demo-projects-1</a>
Process & Approvals	Safety and Building Code Requirements			New York NFPA 885 – ES safety regulations to come out in 2020 for BTM, citing storage in high-demand areas also resulted in building code conflicts, necessitating collaboration to establish appropriate permitting requirements.	NY	21.4	52	13.5	NGA (2016); K&L Gates (2018); <a href="https://www.utilitydive.com/news/new-yorks-energy-storage-target-could-end-up-at-3-gw-by-2030/526895/">https://www.utilitydive.com/news/new-yorks-energy-storage-target-could-end-up-at-3-gw-by-2030/526895/</a> (accessed August 2, 2018)

1. Denotes a restructured or vertically-integrated market, defined loosely as the presence of retail choice programs per [https://www.eia.gov/todayinenergy/detail.php?id=6250#tabs\\_RenewablesMaps-4](https://www.eia.gov/todayinenergy/detail.php?id=6250#tabs_RenewablesMaps-4) (last accessed November 27, 2018).  
 2. <https://www.ferc.gov/market-oversight/mkt-electric/southeast.asp> (last accessed November 20, 2018).  
 3. IRP or long-term filing requirements per <https://www.raonline.org/wp-content/uploads/2016/05/rapsynapse-wilsonbiewald-bestpracticesinip-2013-jun-21.pdf> (last accessed November 20, 2018).  
 4. Calculated from data downloaded at <https://www.eia.gov/electricity/state/> (last accessed November 27, 2018).